



Civil Aviation Authority

EMERGENCY AIRWORTHINESS DIRECTIVE



Number: G-2021-0014-E

Issue date: 02 November 2021

Note: In this Airworthiness Directive, references to EU regulations are to those regulations as retained and amended in UK domestic law under the European Union (Withdrawal) Act 2018 and are referenced as "UK Regulation (EU) year/number or UK Regulation (EU) No. number/year".

This Airworthiness Directive (AD) is issued by the UK CAA in accordance with UK Regulation (EU) No. 748/2012 Part 21.A.3B, acting as the Authority of the State of Design / Registry for the affected product(s), under Article 34 of the Air Navigation Order 2016 (ANO) and UK Regulation (EU) 2018/1139.

In accordance with UK Regulation (EU) No. 1321/2014 Annex I (Part-M), M.A.301 / Annex VB (Part-ML), ML.A.301, the continuing airworthiness of an aircraft shall be ensured by accomplishing any applicable ADs. Consequently, no person may operate an aircraft to which an AD applies, except in accordance with the requirements of that AD, unless otherwise specified or agreed by the CAA [Part-M, M.A.303 / Part-ML, ML.A.303].

Manufacturer Name:

CAMERON BALLOONS Ltd

Type/Model Designation(s):

Fuel Cylinders (see detailed Applicability)

Effective Date:	04 November 2021
TCDS:	N/A
Foreign AD (if applicable):	N/A
Superseding AD:	This AD supersedes CAA AD G-2021-0010-E dated 01 October 2021

ATA 28 – Fuel –Cylinder Quick Shut-off Valve Mounting Flange – Inspection / Replacement

Manufacturer(s):

Cameron Balloons Ltd

Applicability:

Fuel cylinders Part No (P/N) CB2901, P/N CB2902 and P/N CB2903, having a serial number (s/n) as listed in **Appendix 1** of this AD, where the cylinder is equipped with a QSO valve (incorporating flanged adaptor P/N CB437 Issue F), and all P/N CB2901, P/N CB2902 and P/N CB2903 cylinders having a s/n not listed in Appendix 1 of this AD that have been fitted with a flanged adaptor P/N CB437 Issue F and released as spare parts under Invoice and Form 1 Numbers as listed in **Appendix 2** of this AD.

Stainless Steel cylinders CB426, CB497, CB599, CB959, CB2088, V20, V30, V40; Titanium cylinders CB2380, CB2383, CB2385, CB2387, T30 (CY-050-A-001) and "Worthington" Aluminium cylinders CB250, may also be affected if fitted with CB437 flanged adaptors supplied on invoice and Form 1 numbers listed in **Appendix 2** of this AD.

These fuel cylinders are known to be installed on, but not limited to, hot air balloons and airships manufactured by Cameron Balloons Ltd, Colt Balloons, Lindstrand Balloons Ltd (LBL), Lindstrand Hot Air Balloons Ltd, Sky Balloons, Thunder Balloons, Thunder & Colt, and Lindstrand Technologies Ltd.

Definitions:

For the purpose of this AD, the following definitions apply:

Affected Part: QSO Flanged Adaptor, Part No. CB437 Issue F as defined in “Applicability” above

Serviceable Part: QSO Flanged Adaptor, Part No. CB437 Issue G or later

The SB: Cameron Balloon Service Bulletin SB32

Reason:

Certain Cameron Hot Air Balloon fuel cylinders are supplied with liquid offtakes that consist of a quarter turn ball valve mounted on a flanged adaptor (P/N CB437, see figure 1). Two recent batches of these adaptors have been manufactured with non-conforming (undersize) threads.

In certain cases, when the minimum sized adaptors are combined with cylinder bosses at maximum tolerance dimension and assembled to fuel cylinders, the thread can impinge (“bottom out”) on the cylinder boss. Although the required tightening torque value can be achieved at installation, the torque required to unscrew the flange could be below the minimum value. In extreme cases the adaptor may be unscrewed by hand.

This condition, if not detected and corrected, could result in an uncontrolled release of liquid propane which in turn could result in a fire hazard that could damage the balloon and its envelope, ultimately leading to a forced emergency landing, during which balloon occupants and persons on the ground could be injured.

To address this potential unsafe condition, Cameron Balloons Ltd. issued the Service Bulletin to provide instructions for the removal from service of the affected parts.

For the reasons described above, this AD retains the requirements of CAA Emergency AD G-2021-0010-E dated 01 October 2021, which required a one-time inspection of each affected fuel cylinder for leakage around the threaded joint between the QSO valve adaptor flange and the cylinder boss and, depending on findings, removal from service of the affected fuel cylinder. The AD also required modification of each fuel cylinder by replacement of the affected part with a serviceable part.

Since AD G-2021-0010-E was issued, additional applicability information has been released by the manufacturer, Cameron Balloons Ltd. Additional serial number applicability for CB2902 Cylinders has been identified and added to the list of affected parts. (See appendix 1).

Required Action(s) and Compliance Time(s):

Required as indicated, unless accomplished previously:

1. From the 04 October 2021 (the effective date of AD 2021-0010-E), before further flight, inspect each fuel cylinder where an affected part is fitted in accordance with the instructions in section 5 of the SB for leakage around the threaded joint between the QSO valve adaptor flange and the cylinder boss.
2. If, during the inspection as required by paragraph 1 of this AD, any leakage is detected, before next flight, remove the cylinder from service in accordance with the instructions of the SB.
3. If no leakage is detected, cylinders may be subject to a torque test. Satisfactory completion of the torque test allows the return of the cylinder to service until 31/01/2022, then final rectification action must be applied to all affected cylinders as per section 5 below. The torque test must be carried out by a Part-66(or appropriately qualified) inspector. Details of the torque test are included in document CBL/TN/DCB/3287 (**See Reference Publications below**).

Cylinders that fail the torque check may be returned to service by replacing the QSO valve with a handwheel valve, P/N CB0824-0001, which has a Rego-type hose connection.

4. From the 04 October 2021 (the effective date of AD 2021-0010-E), do not install an affected part on any cylinder.
5. Within 4 months after 04 October 2021 (the effective date of AD 2021-0010-E), modify each cylinder by replacing the P/N CB437 issue F QSO flanged Adaptor, with a P/N CB437 issue G (or later issue) QSO flanged adaptor in accordance with the instructions of the SB, or by replacing the QSO valve assembly with a handwheel valve part No CB0824-0001 (this part has a Rego-type hose connection).

Reference Publications:

Cameron Balloons Service Bulletin SB 32 (at latest revision)
Cameron Balloons Maintenance Manual (at latest revision)
Document Cameron Balloons CBL/TN/DCB/3287

Remarks:

1. The safety assessment has warranted immediate publication and notification without implementing the full consultation process and an immediate publication and notification.
2. Information about any failures, malfunctions, defects or other occurrences, which may be similar to the unsafe condition addressed by this AD, and which may occur, or have occurred on a product, part or appliance not affected by this AD, can be reported to the CAA aviation safety reporting system. This may include reporting on the same or similar components, other than those covered by the design to which this AD applies, if the same unsafe condition can exist or may develop on an aircraft with those components installed. Such components may be installed under an FAA Parts Manufacturer Approval (PMA), Supplemental Type Certificate (STC) or other modification.
3. Enquiries regarding this Airworthiness Directive should be referred to: ga@caa.co.uk
4. For any questions concerning the technical content of the requirements in this AD, please contact: Cameron Balloons Limited,
St Johns Street,
Bedminster, Bristol, UK,
BS3 4NH
Email: technical@cameronballoons.co.uk tel: +44 (0)117 9637216

Figure 1: *CB437 Flanged Adaptors for Quick Shut-Off (QSO) valves*

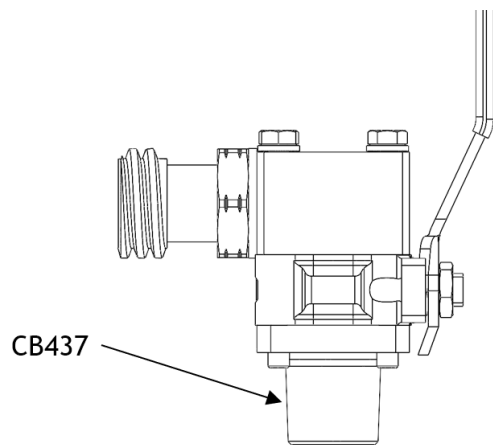

REVISED

Appendix 1: Part numbers and serial numbers of affected cylinders

Part No.	Serial No.
CB2901 Cylinders	B01113, B01114, B01115, B01117, B01118, B01119, B01123, B01124, B01125, B01126, B01127, B01128, B01130, B01131, B01132, B01133, B01134, B01135, B01137, B01138, B01139, B01140, B01141, B01142, B01143, B01152, B01155, B01156, B01157, B01158, B01159, B01160, B01161, B01162, B01166, B01167, B01168, B01169, B01170, B01171, B01172, B01177, B01179, B01180, B01181, B01182, B01183, B01212, B01213, B01214, B01215, B01216, B01217, B01218, B01219, B01220, B01222, B01223, B01227, B01228
CB2902 Cylinders	C00017, C00031, C00032 C00015, C00017, C00019, C00020, C00021, C00025, C00026, C00027, C00028, C00029, C00030, C00031, C00032.
CB2903 Cylinders	D01751, D01752, D01753, D01754, D01761, D01762, D01763, D01764, D01765, D01766, D01767, D01768, D01769, D01770, D01771, D01772, D01773, D01777, D01778, D01779, D01780, D01781, D01782, D01783, D01784, D01785, D01786, D01787, D01788, D01789, D01790, D01791, D01792, D01793, D01794, D01795, D01796, D01797, D01798, D01799, D01800, D01801, D01802, D01803, D01804, D01805, D01806, D01807, D01808, D01809, D01810, D01811, D01812, D01814, D01815, D01816, D01817, D01822, D01824, D01825, D01826, D01827, D01828, D01829, D01830, D01831, D01832, D01833, D01834, D01835, D01836, D01837, D01838, D01839, D01840, D01841, D01842, D01844, D01845, D01846, D01847, D01848, D01849, D01850, D01851, D01852, D01853, D01854, D01855, D01856, D01857, D01858, D01859, D01860, D01861, D01862, D01863, D01864, D01865, D01866, D01867, D01868, D01869, D01870, D01871, D01877, D01878, D01879, D01880, D01881, D01882, D01883, D01884, D01885, D01886, D01887, D01888, D01889, D01890, D01891, D01892, D01893, D01894, D01895, D01896, D01897, D01898, D01899, D01900, D01901, D01906, D01907, D01908, D01909, D01910, D01911, D01912, D01913, D01914, D01915, D01916, D01917, D01918, D01919, D01920, D01921, D01922, D01923, D01925, D01926, D01927, D01929, D01930, D01932, D01934, D01935, D01936, D01937, D01938, D01939, D01940, D01941, D01942, D01943, D01944, D01945, D01946, D01947, D01948, D01949, D01950, D01951, D01952, D01953, D01954, D01955, D01956, D01957, D01959, D01961, D01962, D01963, D01964, D01965, D01966, D01967, D01968, D01970, D01971, D01972, D01973, D01974, D01975, D01976, D01750

Appendix 2 : List of Forms 1 and Invoices for released parts

Form 1 number	Quantity	Invoice number
13397	4	12545
12691	12	13044
12585	1	13242
12683	3	13283
12638	6	13444
12726	2	13636
12933	3	14114
12945	4	14118
13044	1	14310
13051	3	14328
13214	1	14783
-	5	14809
13257	1	14888
13259	3	14912
-	3	14952
-	6	15203
13384	4	15274
13450	2	15327
13415	1	15348
13559	4	15643
13644	1	15735
13664	1	15817
13666	1	15830
13670	2	15848
14929	4	15982
13750	2	16018
13844	3	16217
-	1	16237
13880	3	16354
13944	2	16401
13924	6	16439
13979	3	16573
13995	1	16615
14029	1	16702
14027	1	16708
14115	3	16773
-	2	16808
14091	5	16898
14126	2	16956
14160	1	16981
8983	8	17044
14211	1	17153
14255	1	17170
14432	1	17503
12843	8	13740/13933
14024	4	15309/15311
14000	1	16510/16640/16641
14432	1	17503

NOTE: Affected Flanged Adaptors are not visually identifiable by surface finish or type of part marking. The details above must be used as the means of affected part identification.