



Part-SPO Workshop

12 September 2016

Contents



- Specialised Operations
- European Regulations Background
- Operator Requirements
- Authority Requirements
- CAA Enforcement
- Safety Culture

What is Specialised Operations (SPO)?



- 'Specialised Operations' means any operation other than commercial air transport where the aircraft is used for specialised activities such as:
 - agriculture
 - construction
 - photography
 - surveying
 - observation and patrol
 - aerial advertisement
- This covers much of what used to be called 'aerial work'
- More examples of SPO activities and classification criteria can be found in the Acceptable Means of Compliance and Guidance Material
- Some activities may be deemed to be 'High Risk', particularly to third parties, and be subject to prior authorisation

What is a complex motor-powered aircraft?



- **An aeroplane:**

- With a maximum certificated take-off mass exceeding 5,700kg, or
- Certificated for a maximum passenger seating configuration of more than nineteen, or
- Certificated for operation with a minimum crew of at least two pilots, or
- Equipped with (a) turbojet engine(s) or
- Equipped with more than one turboprop engine and exceeding 5,700kg

- **A helicopter certificated:**

- For a maximum take-off mass exceeding 3,175kg, or
- For a maximum passenger seating configuration of more than nine, or
- For operation with a minimum crew of at least two pilots, or

- **A tilt rotor aircraft**

What is a commercial operation?

- 'Commercial operation' shall mean any operation of an aircraft, in return for remuneration or other valuable consideration, which is available to the public or, when not made available to the public, which is performed under a contract between an operator and a customer, where the latter has no control over the operator.

What is an operator?

- 'Operator' shall mean any legal or natural person, operating or proposing to operate one or more aircraft or one or more aerodromes.

Who is affected by SPO?

- Commercial and non-commercial SPO operators
- Complex and non-complex aircraft SPO operators
- 'High Risk' and non-High Risk SPO operators

- Notes:
 - Applicable regardless of aircraft State of Registry
 - Rules in place since 1 July 2014 but applicable from **21 April 2017**



The image shows a helicopter in flight, suspended by a cable, lifting two large metal cages containing Intermediate Bulk Containers (IBCs). Below the helicopter, two ground crew members in high-visibility jackets and hard hats are visible, along with several IBCs on the ground. The entire scene is overlaid with a blue gradient and a large white circular graphic element.

EASA Regulations

The European Union Aviation Safety System



European Aviation Regulations

Rule hierarchy and responsible organisations



Essential Requirements (ER)

- Legally binding requirements adopted by the European Council and Parliament
- Annexed to the Basic Regulation 216/2008

Implementing Rules (IR)

- Legally binding requirements adopted by the European Commission
- Deviations from Implementing Rules are only possible through the flexibility provisions described in Article 14 of the Basic Regulation 216/2008

CS, AMC, GM – EASA Responsibility

Certification Specifications (CS)

- Technical standards to be used in the certification / approval process
- “Building blocks” for the certification basis
- e.g. CS-FTL, CS-FSTD, CS-AWO

Acceptable Means of Compliance (AMC)

- Technical / procedural material
- One means to comply with the rule – but not the only one
- Presumption of compliance with IR

Guidance Material (GM)

- Interpretative / explanatory material
- Provides guidance on how the rules should be understood

Examples for ER, IR, AMC, GM

- **ER (Annex IV of BR) 5.a**

An aircraft must be equipped with all navigation, communication and other equipment necessary for the intended flight.....

- **IR SPO.IDE.A.210 Headset**

(a) Aeroplanes shall be equipped with a headset with a boom microphone or equivalent for each flight crew member.....

- **AMC1 SPO.IDE.A.210 Headset**

GENERAL

(a) A headset consists of a communication device that includes two earphones to receive and a microphone to transmit audio signals to the aeroplane's communication system. To comply with the minimum performance requirements.....

- **GM1 SPO.IDE.A.210 Headset**

GENERAL

The term 'headset' includes any aviation helmet incorporating headphones and microphone worn by a flight crew member.

Flexibility Provisions

These provisions are only available to Member States and applied through the competent authority (CAA in the UK)

- **Article 14 of the Basic Regulation**

- 14 (1) - Reaction to a safety problem
- 14 (4) - Exemption for unforeseen urgent operational needs or operational needs of a limited duration
- 14 (6) - Derogation where an equivalent level of protection to that in the rule can be achieved by other means

European Aviation Regulations

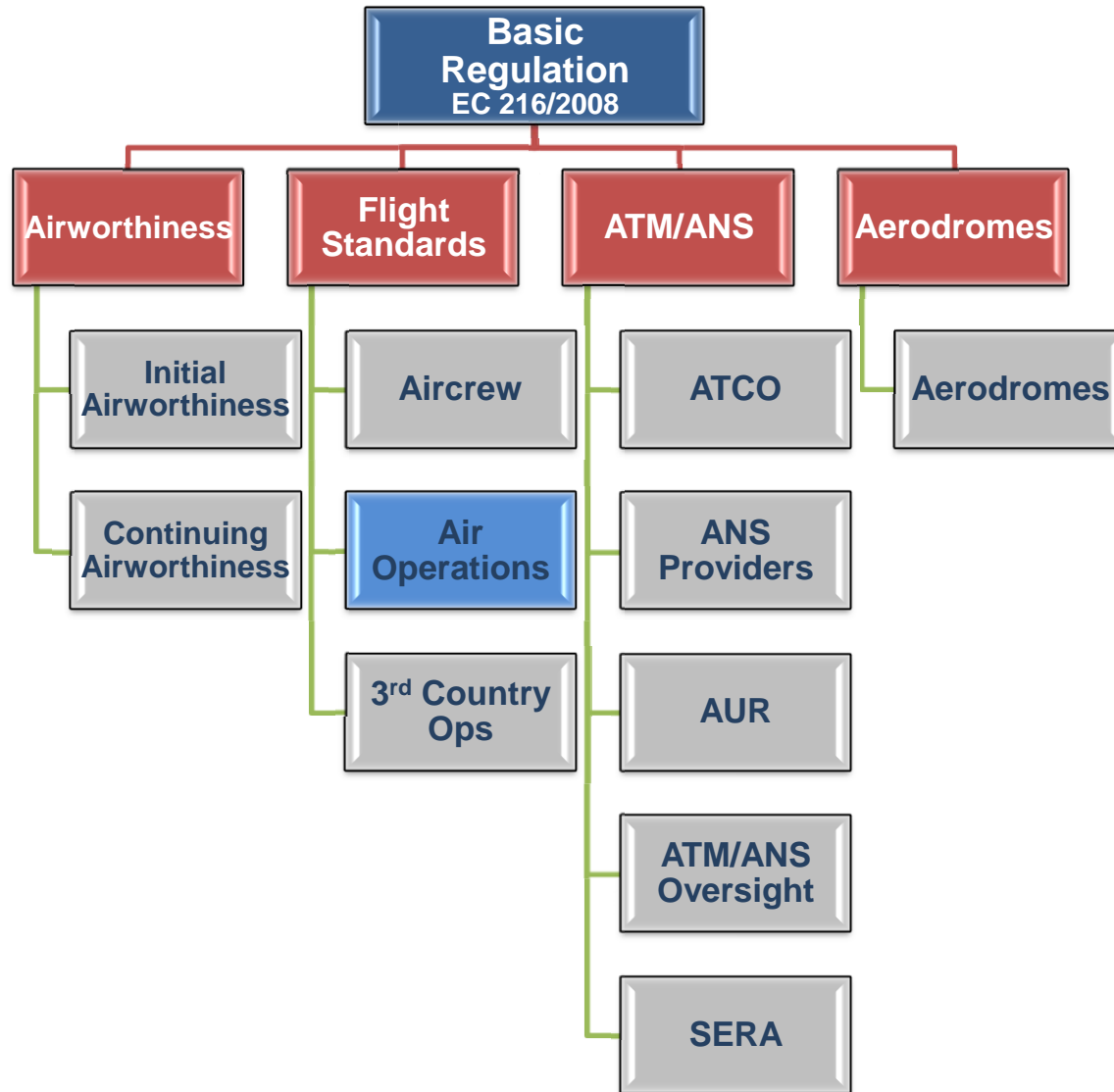



A blue-tinted photograph of a helicopter in flight, lifting two large metal cages (IBC containers) from a ground site. The ground site contains several more IBC containers and two workers in high-visibility gear. The background is a clear blue sky.

EASA Air Operations Regulations

Regulation 965/2012 Air Operations Rule Structure

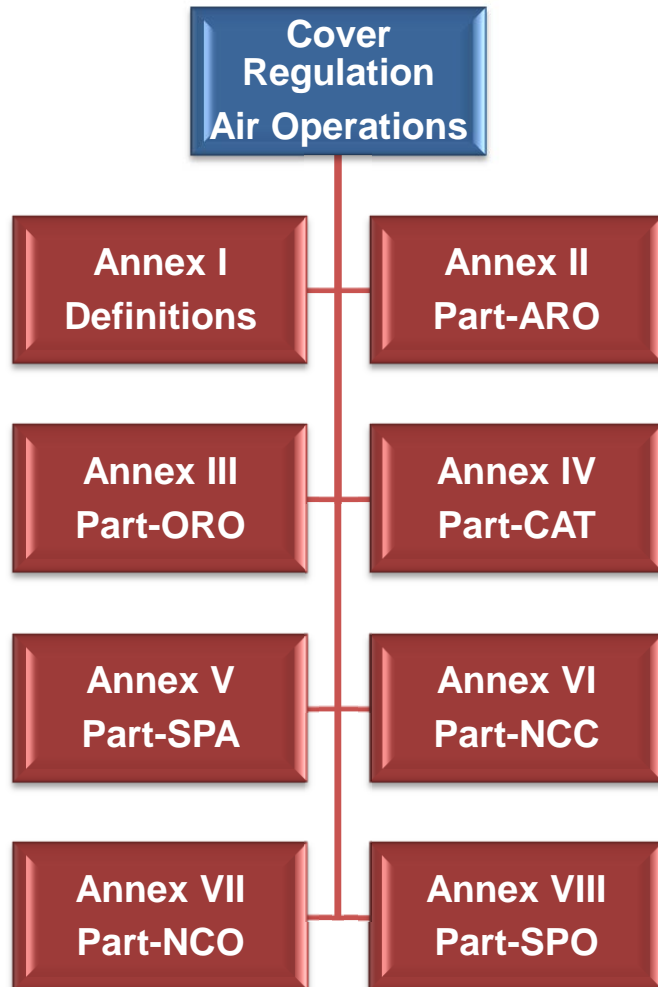

- **Part-ARO:** Authority Requirements Operations
- **Part-ORO:** Organisation Requirements Operations
- **Part-CAT:** Commercial Air Transport operations
- **Part-SPA:** Operations requiring Specific Approvals
- **Part-NCC:** Non-commercial operations with complex motor-powered aircraft
- **Part-NCO:** Non-commercial operations with other-than-complex motor-powered aircraft
- **Part-SPO:** Specialised Operations

Annexes applicable to Specialised Operations

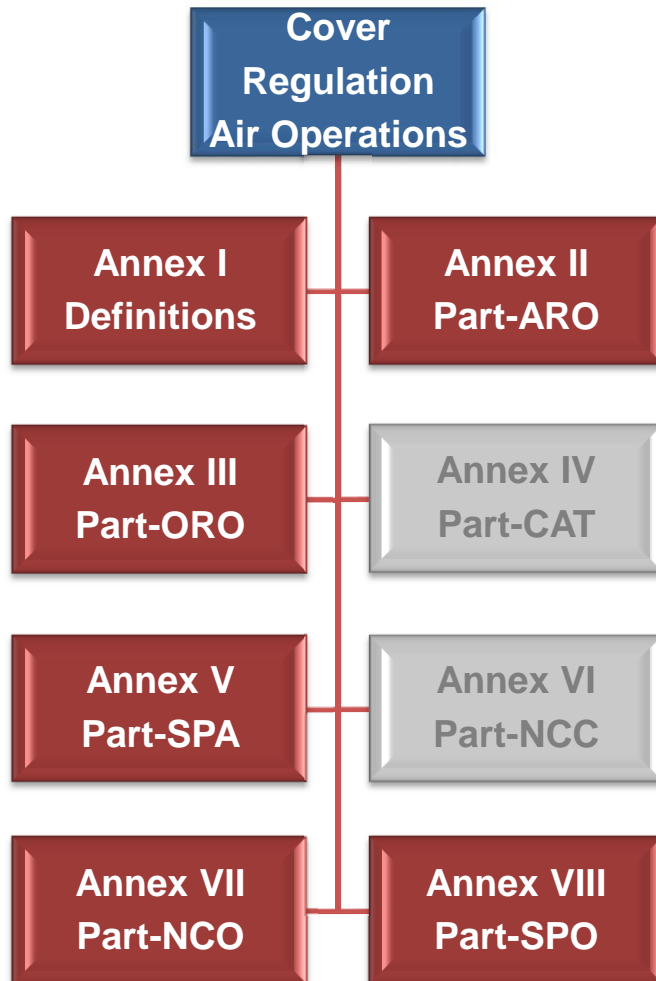

- **Part-ARO:** Authority Requirements Operations
- **Part-ORO:** Organisation Requirements Operations
- **Part-CAT:** Commercial Air Transport operations
- **Part-SPA:** Operations requiring Specific Approvals
- **Part-NCC:** Non-commercial operations with complex motor-powered aircraft
- **Part-NCO:** Non-commercial operations with other-than complex motor-powered aircraft , including NCO.SPEC
- **Part-SPO:** Specialised Operations

Annexes applicable to Specialised Operations



- **Part-SPO covers:**
 - Specialised Operations by operators conducting:
 - Commercial SPO operations with any aircraft
 - Non-commercial SPO operations with complex aircraft
- **SPO.GEN.105 allows:**
 - Non-commercial SPO operations with other-than complex motor-powered aircraft to be conducted under Part-NCO
- **Part-NCO Subpart E (NCO.SPEC) covers:**
 - Specialised Operations by operators conducting non-commercial activities with other-than complex motor-powered aircraft

What does this mean for you?

- The Regulations are structured differently to previous National Rules and are more comprehensive and encompassing
- Part-SPO is not the only Annex of the Regulation which may be applicable
- Non-commercial operations with other-than complex motor-powered aircraft are covered by Part-NCO
- Make sure you are familiar with these Regulations as they apply to Specialised Operations



Annex III Part-ORO

The image shows a helicopter in flight, hoisting two large metal cages or pallets from the ground. The ground crew consists of two workers in high-visibility gear, one of whom is operating a hoist system. The background is a clear blue sky, and the foreground shows several large metal cages (IBC) on the ground. The entire scene is overlaid with a blue gradient and a large white circular graphic element.

Air Operations – Annex III Part-ORO

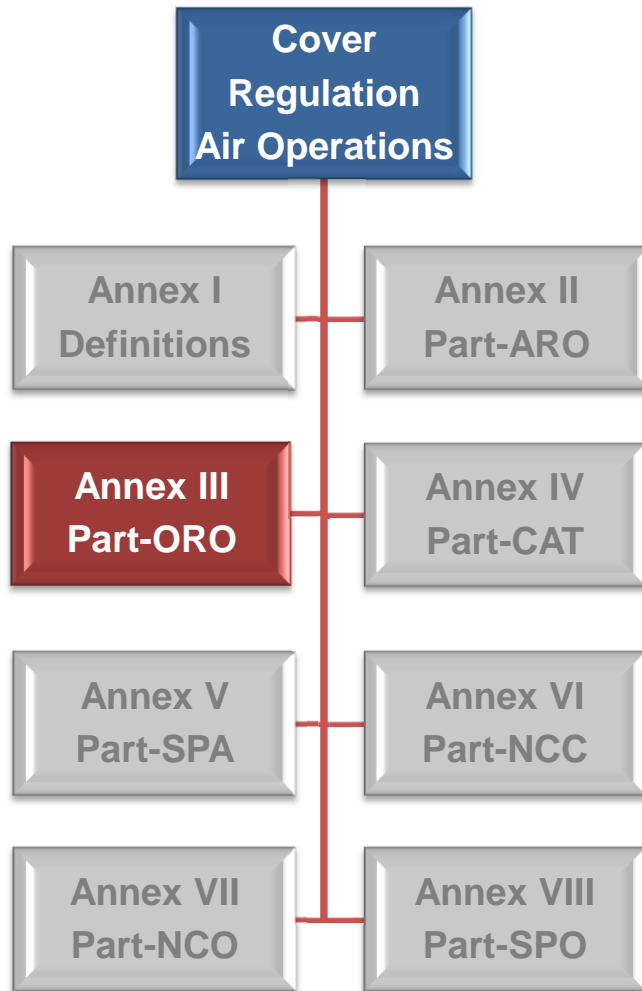

▪ **Applicability:**

- Organisation requirements for:
 - CAT operators
 - NCC operators
 - SPO operators conducting:
 - Commercial SPO operations with any aircraft
 - Non-commercial SPO operations with complex aircraft

Part-ORO - Structure & Applicability

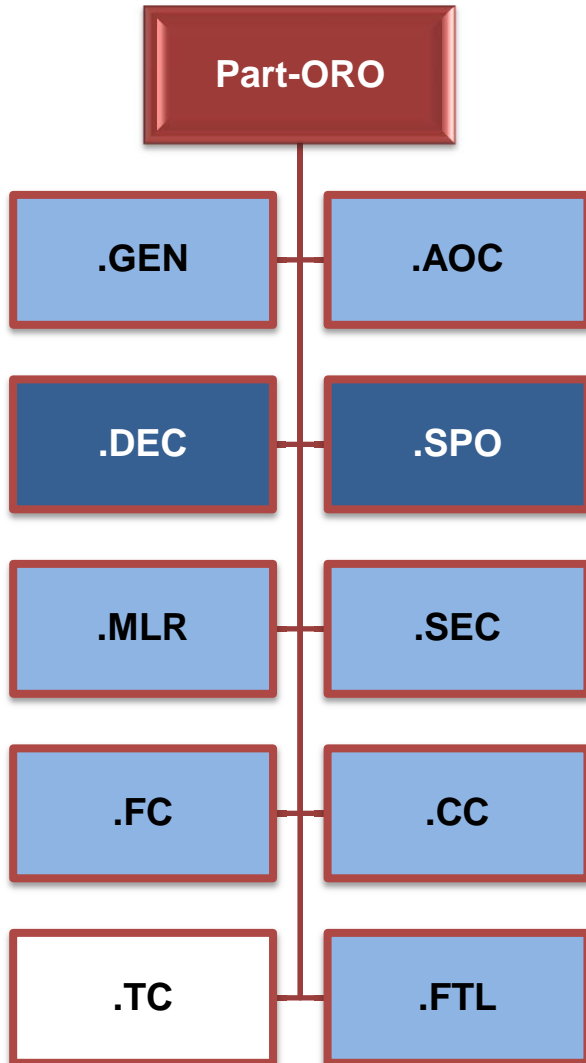

- .GEN** general requirements
- .AOC** air operator certification
- .DEC** declaration
- .SPO** commercial specialised operations
(requires some compliance with AOC)
- .MLR** manual, logs, records
- .SEC** security
- .FC** flight crew
- .CC** cabin crew
- .TC** technical crew
- .FTL** flight and duty time limitations and rest requirements (*yet to be developed*)

Applicability for SPO

Full	Partial	Nil
------	---------	-----

ORO.DEC.100 Declaration

The operator of any aircraft engaged in commercial SPO or the operator of a complex motor-powered aircraft engaged in non-commercial SPO shall:

- (a) provide the competent authority with all relevant information prior to commencing operations, using the form contained in Appendix I to this Annex;
- (b) notify to the competent authority a list of the alternative means of compliance used;
- (c) maintain compliance with the applicable requirements and with the information given in the declaration;
- (d) notify the competent authority without delay of any changes to its declaration or the means of compliance it uses; through submission of an amended declaration using the form contained in Appendix I to this Annex; and
- (e) notify the competent authority when it ceases operation.

Part-ORO.DEC



- **Intent of the Declaration is to:**
 - ensure that the operator has acknowledged its responsibilities under the applicable safety regulations and that it holds all necessary specific approvals
 - inform the competent authority of the existence of any operator required to comply with Part-SPO
 - enable the competent authority to fulfil its oversight responsibilities

Part-ORO.DEC

Declaration Form

Items on the form:

- Operator data
- Continued airworthiness data
- Aircraft operation data
- Details of specific approvals
- List of alternative means of compliance
- Statements on the compliance with applicable rules
- Information on industry standards, if applicable

Part-ORO.GEN



- **Includes:**

- Management system

- “The operator shall establish, implement and maintain a management system that includes:
 - “The management system shall correspond to the size of the operator and the nature and complexity of its activities, taking into account the hazards and associated risks inherent in these activities.”

- AMC and Guidance Material expands for both complex and non-complex operators

ORO.SPO

- **Includes:**
 - Common requirements for commercial specialised operations
 - Includes the following as for AOC operators:
 - Management, supervision and training of personnel
 - Continuing airworthiness
 - Adequacy of facilities
 - Documentation
 - Leasing arrangements
 - Authorisation of High Risk commercial specialised operations
 - Changes to High Risk Authorisations
 - Continued validity of High Risk Authorisations

What is High Risk SPO?

- 'High Risk commercial specialised operation' means:
 - any commercial specialised aircraft operation carried out over an area where the safety of third parties on the ground is likely to be endangered in the event of an emergency, or, as determined by the competent authority of the place where the operation is conducted, any commercial specialised aircraft operation that, due to its specific nature and the local environment in which it is conducted, poses a high risk, in particular to third parties on the ground

High Risk SPO



- Affects commercial SPO only
- The operator requires an Authorisation to conduct High Risk SPO (Ref. ORO.SPO.110)
- ANO 2016 and SERA requirements for 3rd party protection are also relevant
- List of High Risk activities being developed alongside an authorisation process
- More information will be posted on the CAA website in due course

Part-ORO.MLR

- **Includes:**
 - Operations manual (OM)
 - Structure and content
 - Approved minimum equipment list (MEL)
 - Record keeping requirements

Part-ORO.SEC

- Flight crew compartment security

Part-ORO.FC

- **Includes:**
 - Composition of flight crew
 - Designation as pilot-in-command
 - Crew resource management (CRM)
 - Operator conversion training
 - Recurrent training and familiarisation training
 - Operation on more than one type or variant

Commercial Air Transport Operators



- Operators holding an Air Operator Certificate must make a separate SPO Declaration if also conducting SPO flights
- The alleviation from making a Declaration which is shown in ORO.AOC.125 does **not** apply in the case of SPO

What does this mean for you?

- Part-ORO contains detailed organisation rules with which affected SPO operators must comply
- For commercial and complex aircraft SPO a Declaration must be made to the appropriate Competent Authority (CAA in the UK)
- The Declaration process will be available from January 2017
- Commercial operators will require more comprehensive management and personnel arrangements
- SPO with non-commercial other-than complex motor-powered aircraft will be conducted in accordance with Part-NCO



Annex VIII Part-SPO

Air Operations – Annex VIII Part-SPO

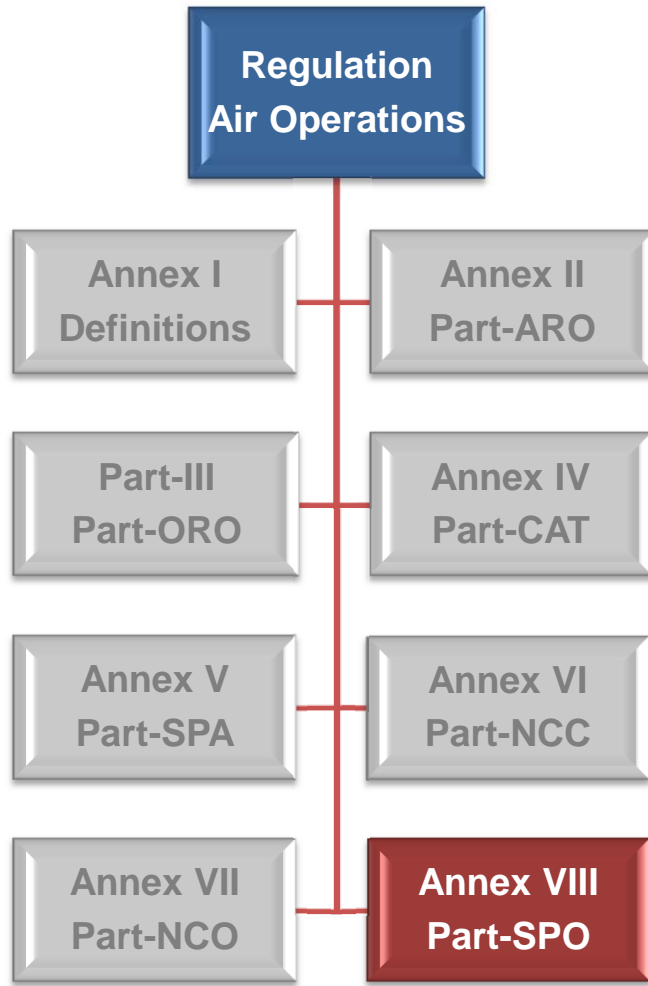

- **Applicability:**

- Technical rules for Specialised Operations of:
 - non-commercial operations of complex motor-powered aircraft
 - commercial operations

Annex VIII Part-SPO - Rule Structure

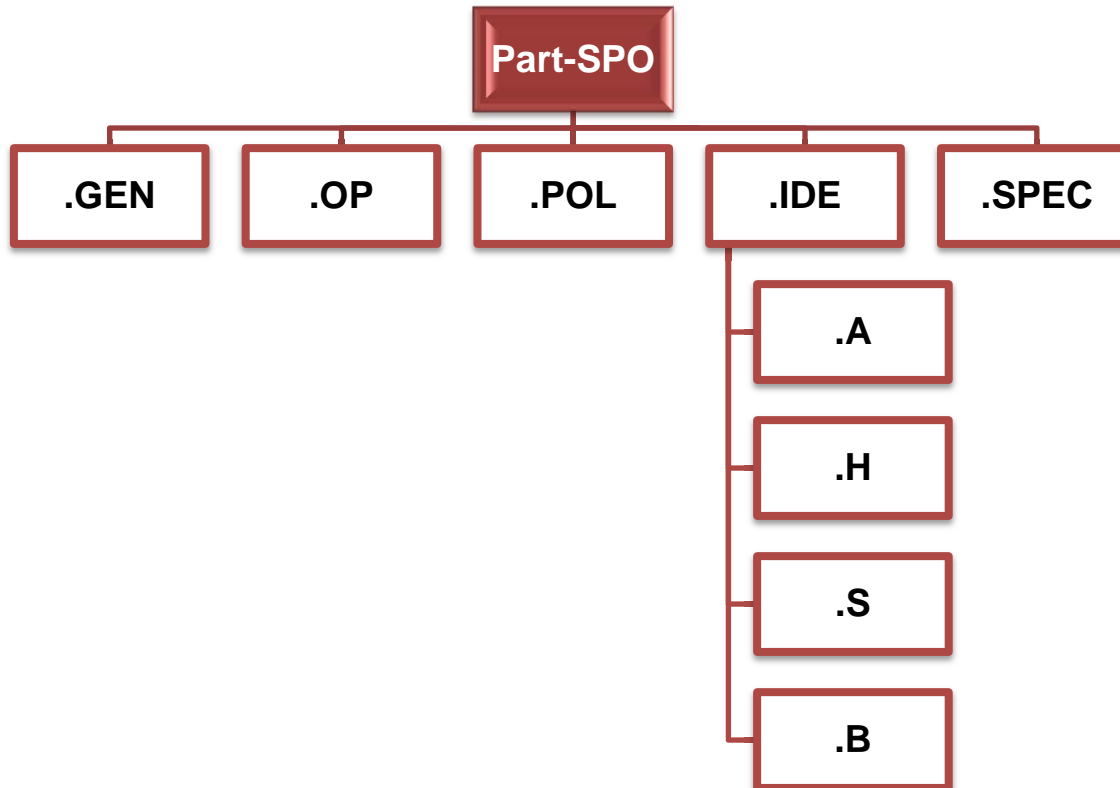

.GEN – general requirements

.OP – operational procedures

.POL – performance and operating limitations

.IDE – instruments, data, equipment

.A - aeroplanes

.H – helicopters

.S – sailplanes*

.B – balloons*

.SPEC – specific requirements

* The Air Operations Regulations for Sailplanes and Balloons have been deferred until 8th April 2018 for Balloons and 8th April 2019 for Sailplanes.

Part-SPO.GEN

- **Includes:**
 - Scope and applicability
 - Crew and Task Specialist responsibilities
 - Pilot-in-command responsibilities and authority
 - Compliance with laws and regulations
 - Taxiing of aircraft
 - Portable electronic devices
 - Documents, manuals and information to be carried
 - Preservation and production of documents
 - Transport of dangerous goods

Part-SPO.GEN

- **“Task Specialist”** means:
 - a person assigned by the operator or a third party, or acting as an undertaking, who performs tasks on the ground directly associated with a specialised task or performs specialised tasks on board or from the aircraft
 - Task Specialist responsibilities include the proper execution of duties in accordance with operating procedures
 - Note: When a Task Specialist is not operating in that capacity on a flight then he/she reverts to being a passenger

Part-SPO.OP

- **Includes:**
 - Standard operating procedures (SOP)
 - Aerodrome operating minima
 - Departure and approach procedures
 - Noise abatement procedures
 - Flight preparation (Flight Planning)
 - Safety briefing
 - In-flight fuel management
 - Use of oxygen
 - Ground proximity detection
 - Airborne collision avoidance system (ACAS II)

▪ **Standard Operating Procedures**

- Prior to any SPO, the operator must:
 - conduct a risk assessment to determine the hazards and associated risks
 - establish SOPs based on the risk assessment, the specialised activity and aircraft used
- The SOP shall be part of the Operations Manual or a separate document
- The SOP shall be regularly reviewed and updated
- Any specialised operation must be conducted in accordance with the SOP and in compliance with Part-SPO
- Task specialist procedures must be specified in the SOP

Part-SPO.POL

- **Includes:**
 - Operating limitations (AFM, OM)
 - Mass and balance, loading
 - Performance (general and aeroplane/helicopter specific)

Part-SPO.IDE (Aeroplanes and Helicopters)



- **Includes:**
 - Instruments and equipment
 - Operations under VFR and IFR
 - TAWS
 - FDRs/CVRs
 - Seats, safety belts and restraint systems
 - Supplemental oxygen
 - Survival equipment
 - ELTs
 - Radio communication & navigation equipment

Part-SPO.SPEC

- **Includes specific requirements for:**
 - Helicopter external sling operations (HESLO)
 - Human external cargo operations (HEC)
 - Parachute operations (PAR)
 - Aerobatic flights (ABF)

What does this mean for you?

- Part-SPO contains detailed operating rules, performance and equipment requirements which you must comply with
- Requirements for SOPs and Task Specialists
- There are Acceptable Means of Compliance (AMC) and Guidance Material (GM) to help you comply
- Alternative Means of Compliance (AltMoc) may be used subject to them meeting the intent of the rule and being advised to the CAA under any Declaration



Annex VII Part-NCO

Air Operations – Annex VII Part-NCO

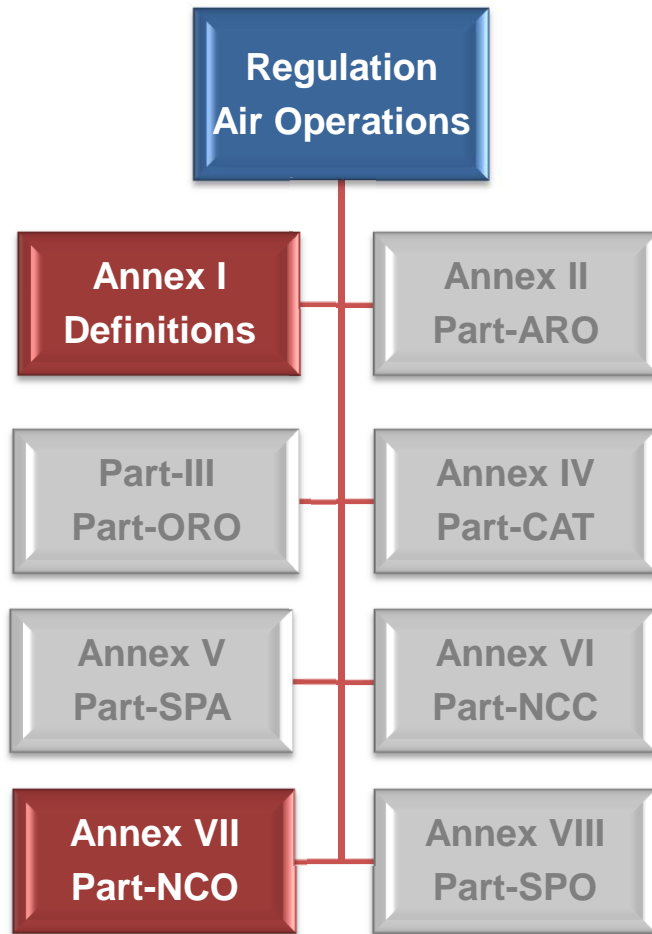

Applicability

- Technical rules for:
 - Non-commercial operations of other-than complex motor-powered aircraft including sailplanes and balloons

Annex VII Part-NCO

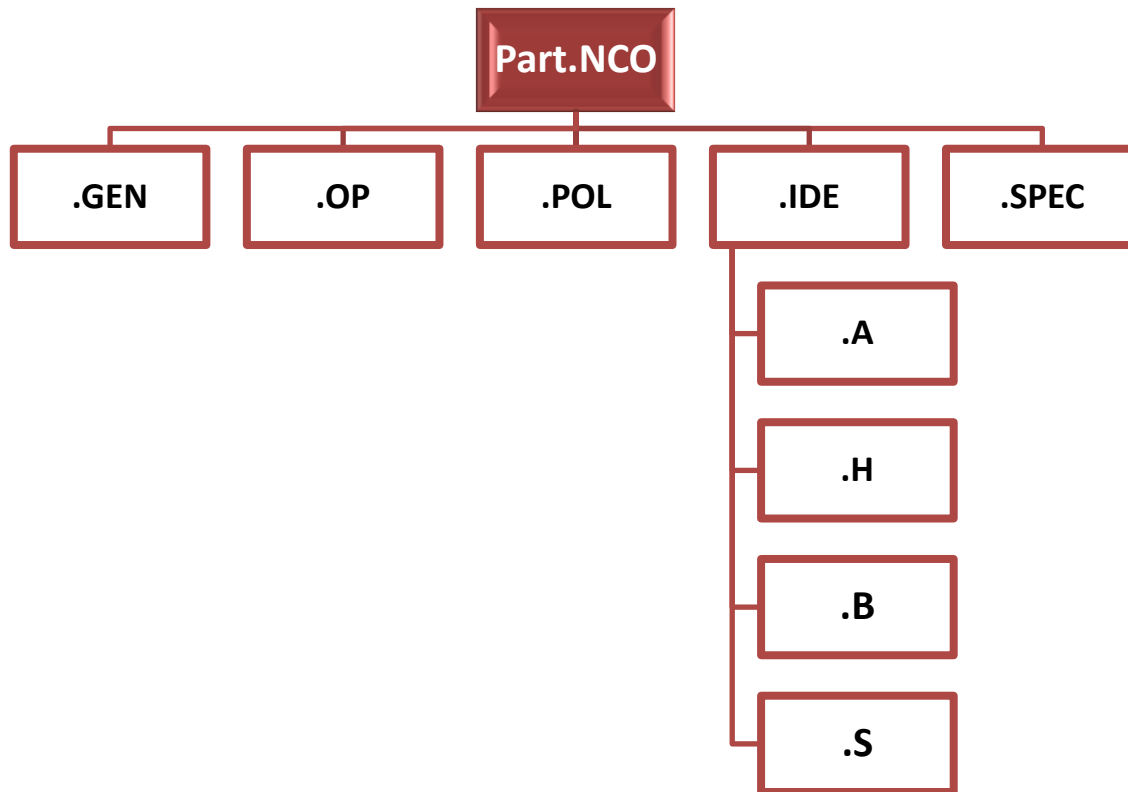

.GEN – general requirements

.OP – operational procedures

.POL – performance and operating limitations

.IDE – instruments, data, equipment

.A - aeroplanes

.H – helicopters

.B -balloons*

.S – sailplanes*

.SPEC – specific requirements

* The Air Operations Regulations for Sailplanes and Balloons have been deferred until 8th April 2018 for Balloons and 8th April 2019 for Sailplanes.

Part-NCO Subpart E NCO.SPEC



- Is effectively a subset of Part-SPO with a lighter touch for non-commercial specialised operations
- Applies to any non-commercial specialised activity in other-than complex motor-powered EASA aircraft, including but not limited to:
 - Helicopter external sling loads
 - Human external cargo
 - Parachute operations
 - Aerobatic flights
- Compliance with all the appropriate elements of Part-NCO are still required
- Some elements of the ANO continue to apply to all UK registered aircraft and other aircraft operating within the UK.

Are my Operating Rules Part.SPO or Part-NCO NCO.SPEC?

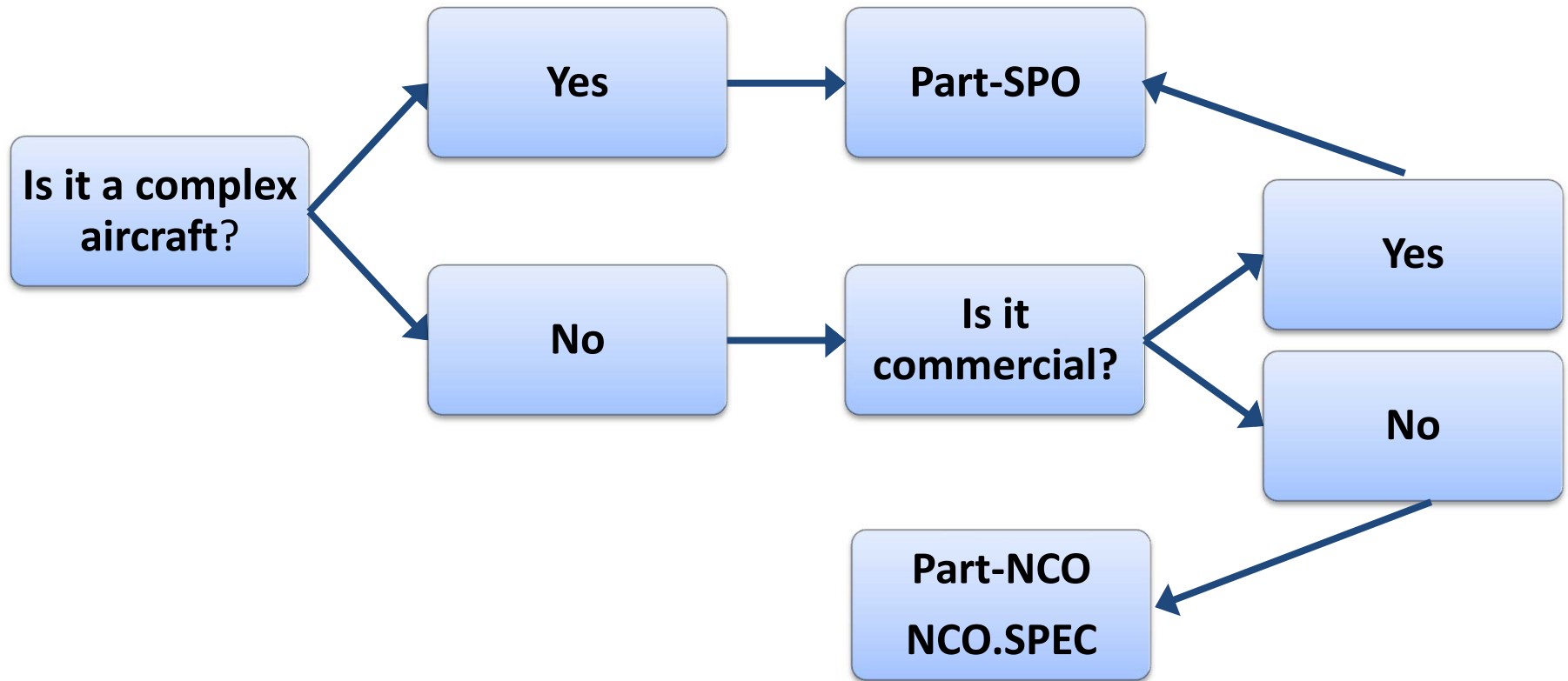

NCO.SPEC

- If the activity does fall within the scope of a non-commercial SPO the PIC shall comply with all the assigned requirements. These include (*not exhaustive*):

- conducting a risk assessment
- using a checklist based on the risk assessment
- briefing crew members on the procedures to be carried out including in the event of a forced landing



What does this mean for you?



- Non-commercial SPO with other-than complex motor-powered aircraft may be conducted in accordance with Part-NCO
- NCO.SPEC provides specific requirements for specialised operations in such aircraft
- AMC to NCO.SPEC.100 - Scope provides guidance on how to determine whether an activity is a specialised operation

Here are some of the criteria used to determine if an activity is a specialised operation:

Will the aircraft be flown close to the ground in order to fulfil the mission?

Are abnormal manoeuvres to be performed?

Will persons enter or leave the aircraft during flight?



Annex V Part-SPA

Annex V Part-SPA

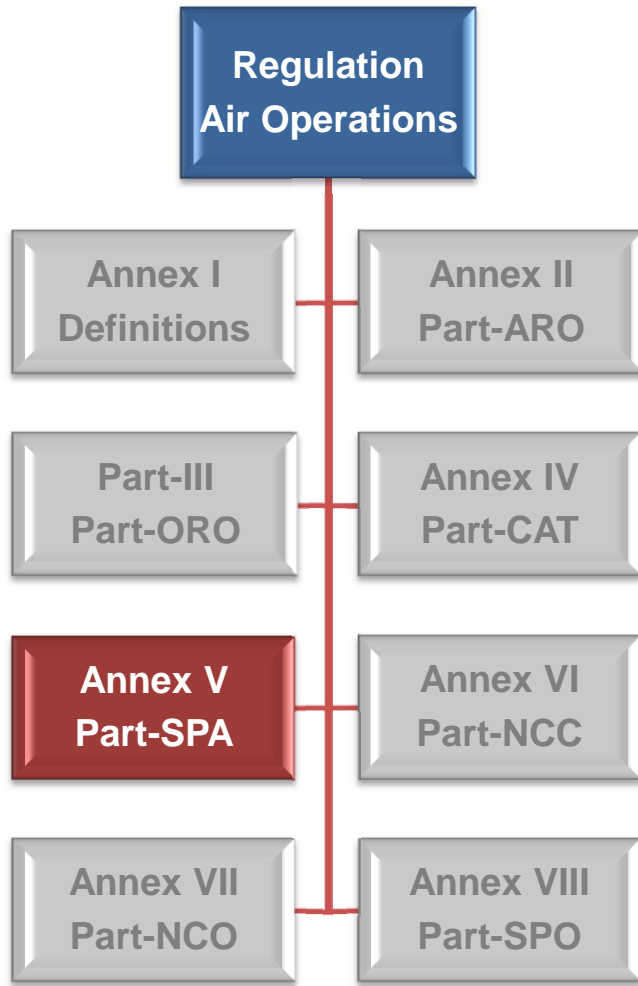

- **Applicability:**

- Operators which wish to conduct an operation requiring a Specific Approval
- To be documented in:
 - OPSPECS for certified operators
 - List of specific approvals for non-certified operators

Part-SPA – Rule Structure & SPO Applicability

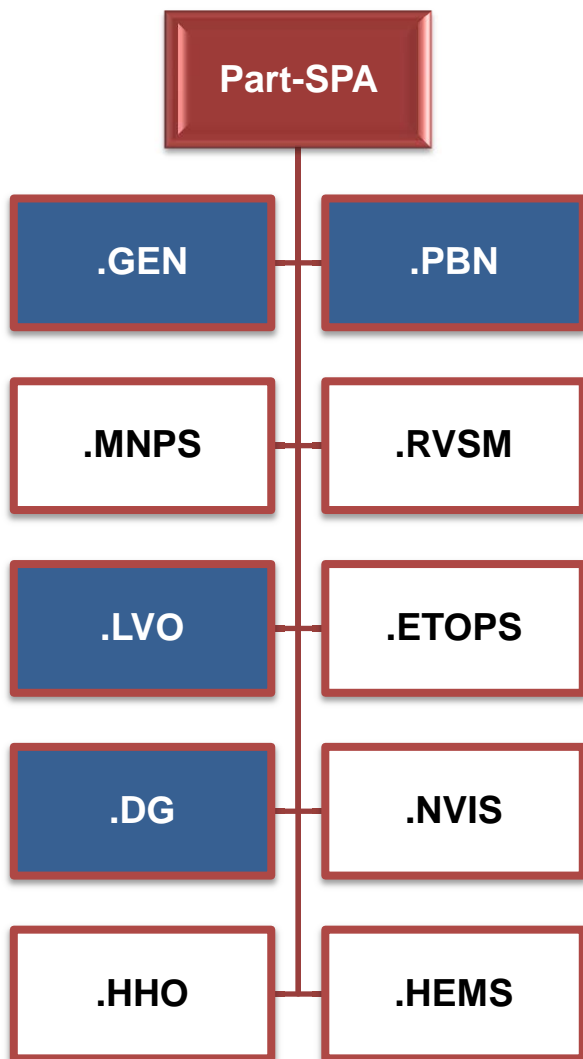

.GEN – general requirements

.PBN – performance based navigation

.MNPS – minimum navigation performance specifications

.RVSM – reduced vertical separation minima

.LVO – low visibility operations

.ETOPS – extended range operations with two-engined aeroplanes (CAT only)

.DG – dangerous goods

.NVIS – night vision imaging systems (CAT only)

.HHO – helicopter hoist operations (CAT only)

.HEMS – helicopter emergency medical services (CAT only)

Full

Partial

Nil

Part-SPA.GEN



- **Competent Authority (SPA.GEN.100)**
 - 965/2012 uses the State of the operator principle
 - The competent authority for issuing a specific approval for non-commercial operators shall be the State in which the operator is established or residing
 - For non-commercial operators using an aircraft registered in a non-EU country, the rules for the approval of PBN, MNPS and RVSM do not apply, if the State of the registry issued approvals for such operations
- **List of Specific Approvals (SPA.GEN.110)**
 - Approvals have to be documented in the list of specific approvals, issued by the competent authority
 - The operator has to carry the document on board the aircraft

Part-SPA.GEN

- **Changes (SPA.GEN.115)**
 - Any change to the conditions of a specific approval requires a prior approval of the competent authority
 - This also includes alternative means of compliances developed by the operator

- **Validity (SPA.GEN.120)**
 - Specific approvals are issued for an unlimited duration
 - This also implies that the competent authority provides continuous oversight over such operations

What does this mean for you?

- Part-SPA contains details of activities which must have **prior** approval before being undertaken
- SPA approvals must be included in the Declaration, where appropriate, and applied accordingly
- Operations Manual procedures including any necessary training should be developed appropriately and may need to be supplied with approval application
- Individual aircraft must have the required equipment and necessary airworthiness approvals



Annex II Part-ARO

The image shows a helicopter in flight, hoisting two large metal cages or baskets from the ground. The helicopter is positioned in the upper center of the frame, with its main rotor blades blurred from motion. A long cable extends from the helicopter down to the cages. In the lower left foreground, two ground crew members in high-visibility jackets and helmets are visible, looking towards the helicopter. The background is a clear blue sky. The entire image is overlaid with a blue gradient and a large white circular graphic element on the left side.

Annex II Part-ARO

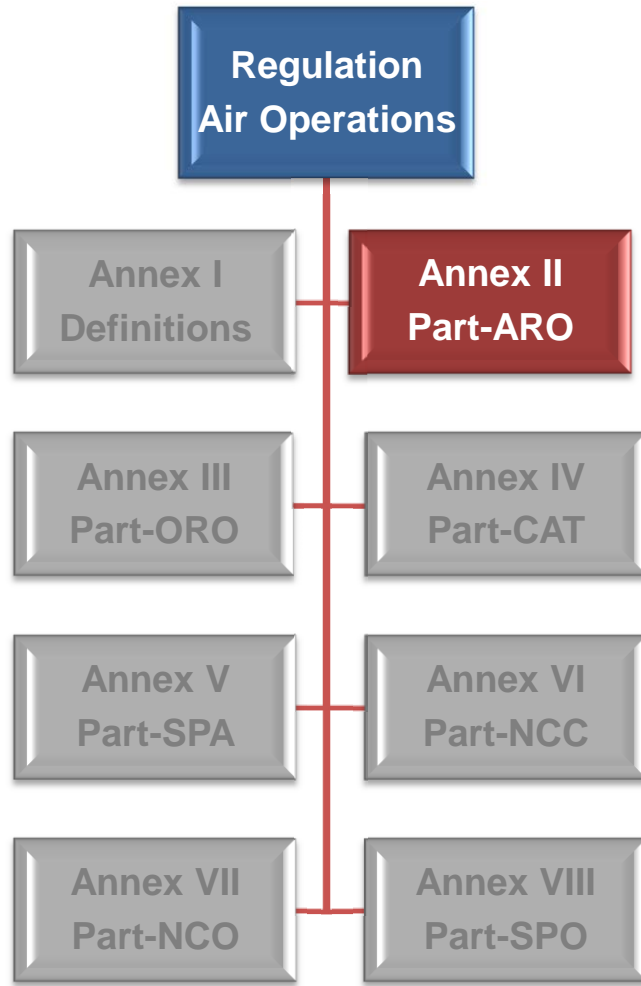

- **Applicability:**

- Authority Requirements for Air Operations for:
 - Competent Authorities (National Aviation Authorities)
 - EASA

Part-ARO – Rule Structure

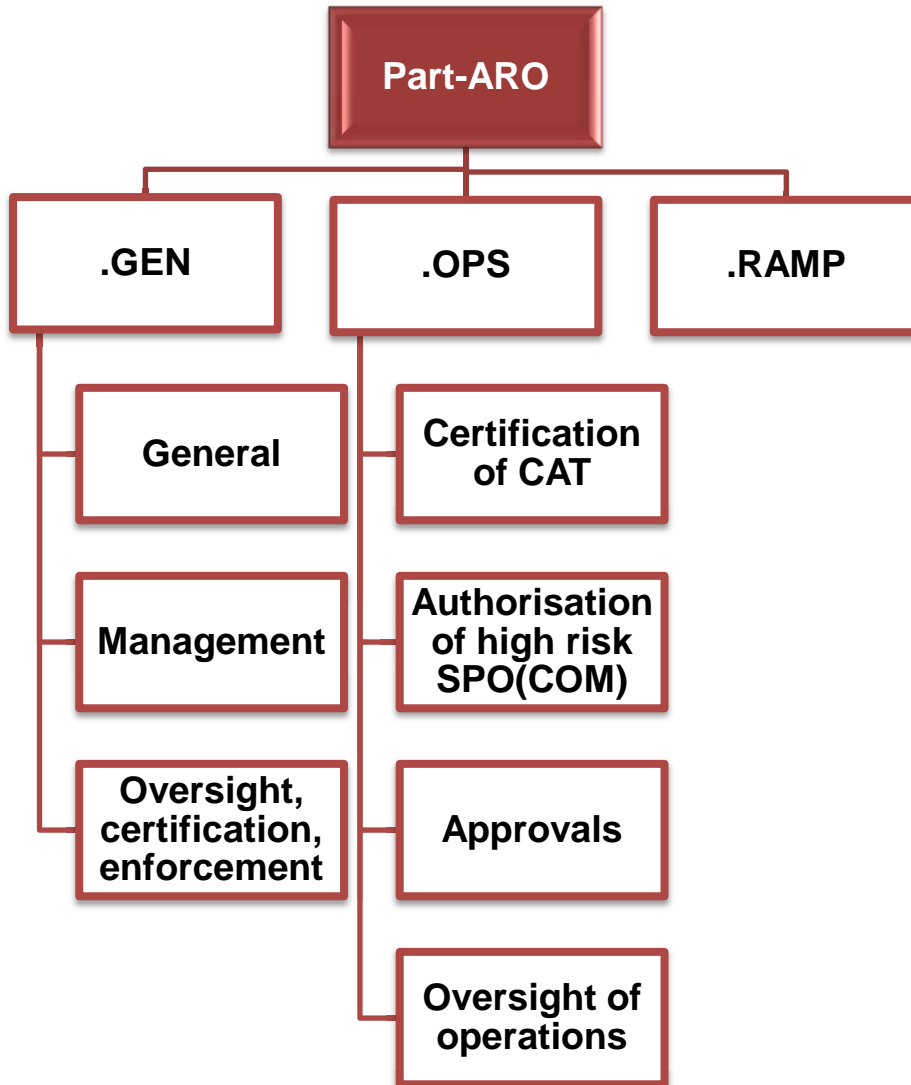

ARO Authority Requirements

.GEN general requirements

.OPS air operations

.RAMP ramp inspections

Part-ARO – Specific Rules for SPO Operations



- **Oversight (ARO.GEN.300 & 305)**
 - The competent authority shall verify continued compliance with:
 - the applicable requirements of organisations it has certified, specialised operations it has authorised and organisations from whom it received a declaration
 - continued compliance with the applicable requirements of non-commercial operators of other-than complex motor-powered aircraft
 - The competent authority shall establish and maintain an oversight programme for declared organisations or those holding a SPO HR authorisation, it shall:
 - take into account the specific nature of the organisation, the complexity of its activities and the results of past oversight activities
 - be based on the assessment of associated risks
 - include audits and inspections, including ramp and unannounced inspections, as appropriate

Part-ARO – Specific Rules for SPO Operations

- **FINDINGS (ARO.GEN.350)**

- A level 1 finding shall be issued when any significant non-compliance is detected which lowers safety or seriously hazards flight safety.
- The level 1 findings shall include:
 - (1) failure to give the competent authority access to the organisation's facilities during normal operating hours and after two written requests;
 - (2) obtaining or maintaining the validity of the organisation certificate or specialised operation authorisation by falsification of submitted documentary evidence;
 - (3) evidence of malpractice or fraudulent use of the organisation certificate or specialised operation authorisation; and
 - (4) the lack of an accountable manager.
- A level 2 finding shall be issued when any non-compliance is detected with the organisation's procedures and manuals or with the terms of an approval, certificate, specialised operation authorisation or with the content of a declaration which could lower safety or hazard flight safety.

What does this mean for you?



- These are new requirements with which the CAA must comply
- This will result in additional active oversight of your operations

ENFORCING REGULATIONS

Simon Pollock
Investigation Officer

“As the UK’s specialist aviation regulator, the CAA’s sole purpose is to protect the interests of the consumers and the public. This goal is central to our work in safety, market regulation and consumer protection, and in relation to airspace and the environment. Our ambition is that routine compliance with civil aviation rules and regulations is the norm.

We recognise, though, that we have not yet reached that position and that **we must continue to take action to detect and respond to breaches of civil aviation requirements. Our purpose in taking action is to ensure that consumers and the public can benefit from an aviation industry that is safe and sustainable and provides choice and value”**

A handwritten signature in black ink that reads 'Andrew Haines'.

Andrew Haines, CAA Chief Executive

Enforcement is...

Any activity that is carried out in order to seek to effectively remedy a breach, or suspected or potential breach, of rules applicable to civil aviation

And the CAA will do it by...

- Using a proportionate and risk-based approach
- Taking independent, evidence-based decisions
- Publicising our enforcement action in the interests of the consumer and the public

COLLABORATION AND FACILITATION

- **Day to day interaction with those we regulate**

ADVISORY

- **Guidance to regulated parties**
- **Verbal warnings**
- **Using publicity to highlight issues and encourage compliance**

FORMAL ENFORCEMENT TOOLS

- **Audit findings**
- **Warning letter**
- **On Notice**
- **'No-fly' Directions**
- **Variation of certificate, licence or approval**
- **Suspension of certificate, licence or approval**
- **Revocation of certificate, licence or approval**
- **Formal caution**
- **Conditional caution**
- **Prosecutions**

The CAA expects organisations and individuals to: *f*

- be aware of their legal obligations and observe them.
- be proactive in being aware of planned changes to regulation, planning for their implementation, and remaining compliant with them at all times.
- seek clarification from us where the regulations and/or legislation appear to be unclear, or the organisation or individual disagrees with our understanding of the law, or has difficulties in ensuring compliance.

Scenarios



During an audit of a holder of an SPO HR authorisation , it is found that system for monitoring the training records of crews has failed & pilots' recurrent training and tests have not been revalidated.

Enforcement action: Level 1 finding, i.e. a potential of significant risk to flight safety; possible suspension or part suspension of the SPO HR authorisation.

Corrective action: Crews affected unable to fly until recurrent training & tests revalidated; short-term corrective action required to ensure no other crews are rostered when out of check; longer term corrective action required to re-establish a robust monitoring system.

Information received that records have been falsified.

Enforcement action: Possible suspension or part suspension of licence, certification or approval; referral for criminal investigation.

Corrective action: Cessation of activities reliant upon the falsified records until falsely recorded events re-taken, repeated or confirmed; individuals involved removed from the process.

Information received that aircraft uninsured or under-insured

Enforcement action: Issue a grounding order; possible suspension of licence, certification or approval; referral for criminal investigation.

Corrective action: Owner/operator acquires/increases level of insurance and supplies evidence.

Some criminal offences prosecuted in 2015/16



- Causing dangerous goods to be carried on an aircraft (Fine £5000; Compensation £1050)
- Landing within 1000m of an open-air assembly of more than 1000 persons (Fine £400)
- Taking-off within 1000m of an open-air assembly of more than 1000 persons (Fine £400)
- Failing to produce pilot's licence and Personal Flying Log Book when required to do so (Fine £100 on each)
- Negligently causing an aircraft to endanger a person (Fine £3000)
- Five counts of making flight accommodation available without holding a Air Travel Organisers' Licence (Fine £300 on each; compensation £1930)
- Flying in Class D controlled airspace without Air Traffic Control clearance (Fine £1700)
- Three counts of knowingly providing the CAA with seven false insurance certificates (9 months imprisonment, suspended for 18 months)
- Using a forged medical certificate with intent to deceive (Fine £2000)
- Flying within the Glastonbury Festival restricted airspace (Fine £400)

Safety Culture & EC376/2014

Sean Parker

Same status as EASA
Basic Regulation
216/2008

EC Regulation 376/2014 on the Reporting, *Analysis and Follow Up* of Occurrences in Civil Aviation

Entry into Force May 2014
Applicable from 15 Nov 2015

EC376/2014 - Applicability

- Each **organisation** established in a Member State shall establish a mandatory reporting system to facilitate the collection of details of occurrences
- ‘**organisation**’ means any organisation providing aviation products and/or which employs, contracts or uses the services of **persons** required to report occurrences
- The following **persons** shall report the occurrences:
 - Pilot, Engineer, ATCO, ground handler etc....

Why was the previous legislation changed?



- The old Directive and corresponding national legislation only identified individuals who should report occurrences to the CAA; pilots, engineers, ATCO etc.
- The role organisations play in enabling reporting and using the information to improve safety was not reflected in the Directive
- The Regulation now defines organisational responsibilities in line with Safety Management System principles – i.e. mandates an **Internal Reporting System**

SMS Principles...?

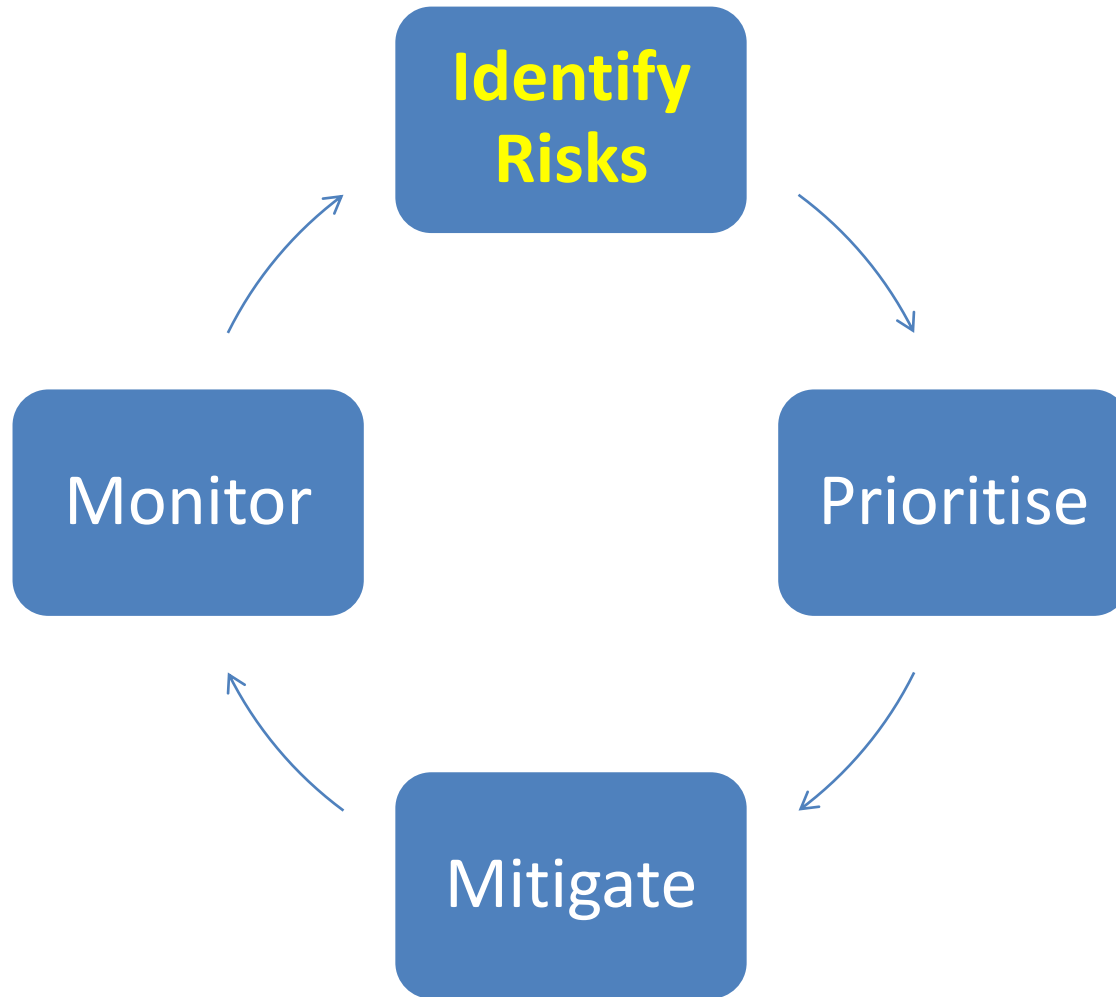

‘Just Culture’ in EC376/2014

- Definition of **Just Culture** introduced into the EU Regulation, Art 2(12)

*A culture in which front-line operators or other persons are not punished for actions, omissions or decisions taken by them that are commensurate with their experience and training, **but** in which gross negligence, wilful violations and destructive acts are not tolerated*

What is a Just Culture?

Cultivating an atmosphere where people have confidence to report safety concerns without fear of blame. Employees must know that confidentiality will be maintained and that the information they submit will be acted upon, otherwise they will decide that there is no benefit in their reporting.

Errors and unsafe acts will not be punished if the error was unintentional. However, those who act recklessly or take deliberate and unjustifiable risks will still be subject to disciplinary action.



Organisation collects and analyses relevant data, and actively disseminates safety information.

Organisation is able to learn from its mistakes and make changes. It will also ensure that people understand the SMS processes at a personal level.

Organisation and the people in it are capable of adapting effectively to changing demands.

‘Just Culture’ must be guaranteed!

- *Organisations must implement a just culture, Art 16(11):-*
*Each organisation established in a Member State shall, after consulting its staff representatives, adopt internal rules describing how ‘just culture’ principles are **guaranteed and implemented within that organisation.***
- Employees and contracted personnel may report to the Member State alleged infringements of these rules.
- Employees and contracted personnel shall not be penalised for reporting alleged infringements. Employees and contracted personnel may inform the Commission about such alleged infringements.

Not entirely a new idea

A fault revealed voluntarily will be treated leniently but a fault concealed may lead to serious consequences for the workman, not to mention the pilot

Hurricane
production
1940



Just Culture: Reasons to Report, or not.....

YES – Report it!

Don't want aircraft to crash

I know I'm supposed to

Somebody saw me

It might happen again

I might get thanked

The system will support me

It's the law

Easy to complete a report

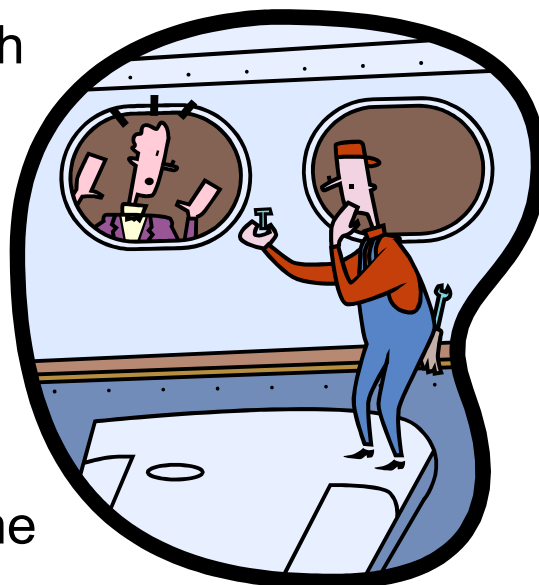

NO – Hide it!

I might get fired

Nothing will change

I'll look foolish

I might lose my Licence

Nobody noticed

It's unimportant

It's too difficult

Don't forget!

- Details on CAA website:
 - www.caa.co.uk/SPO
- EASA website:
 - <https://www.easa.europa.eu/easa-and-you/air-operations/specialised-operations-spo>
 - <http://easa.europa.eu/easa-and-you/general-aviation/operations-general-aviation>
 - <http://easa.europa.eu/regulations>