

---

This appendix to the EASA TCDS A.003 was created to publish selected special conditions, deviations or equivalent safety findings that are part of the applicable certification basis:

Table of Content:

### **SPECIAL CONDITIONS**

D-252: Lightning Protection Indirect Effects .....	2
D-302: Lightning Protection Indirect Effects .....	3
D-5: Protection from External High Intensity Radiated Fields .....	4
D-6: Lightning Protection Requirements .....	6
D-GEN01 PTC: Fire Resistance of Thermal Insulation Material .....	7
D-GEN02 PTC Application of heat release and smoke density requirements to seat materials .....	18
D-GEN7 Flammability Testing Hierarchy .....	19
F-02: Access to Class E Cargo Compartments in Flight .....	20
F-GEN 9-1: Minimum Mass Flow of Supplemental Oxygen "Component Qualification" .....	21
F-GEN 9-3: Crew Determination of Quantity of Oxygen in Passenger Oxygen System .....	22
H-01: Enhanced Airworthiness Programme for Aeroplane Systems – ICA on EWIS.....	23

<b>SPECIAL CONDITION</b>	<b>D-252: Lightning Protection Indirect Effects</b>
APPLICABILITY:	777-200, (including „IGW“)
REQUIREMENTS:	JAR 25.581, 25X899, 25.954, 25.1309
ADVISORY MATERIAL:	N/A

Recent knowledge on severe and multiple lightning strike levels needs to be taken into consideration in establishing the acceptability of the provisions employed for the protection from indirect effects of lightning strike. According to JAA Interim Policy INT/POL/25/4 Issue 2<sup>1</sup>, dated 01-10-94, the following special condition should be applied:

"Each system whose failure to function properly would prevent the continued safe flight and landing of the aircraft, must be designed and installed to ensure that the aircraft can perform its intended function during and after exposure to lightning.

Each system whose failure to function properly would reduce the capacity of the airplane or the ability of the flight crew to cope with adverse operating conditions must be designed and installed to ensure that it can perform its intended function after exposure to lightning.

The lightning strike models to be used for system justification shall be as described in FAA AC 20-136 dated March 5, 1990 with the following modifications:

Appendix III of AC 20-136 defines the multiple burst lightning waveform. The revised waveform to be used instead, comprises repetitive Component waveforms in 3 sets of 20 pulses each as shown in Appendix 1. (see next page)

The minimum time between individual Component H Pulses within a burst is 50 ms, the maximum time is 1000 ms. The minimum time between subsequent bursts is 30 ms, and the maximum time is 300 ms."

APPENDIX 1 TO CRID-252

Page 1/1

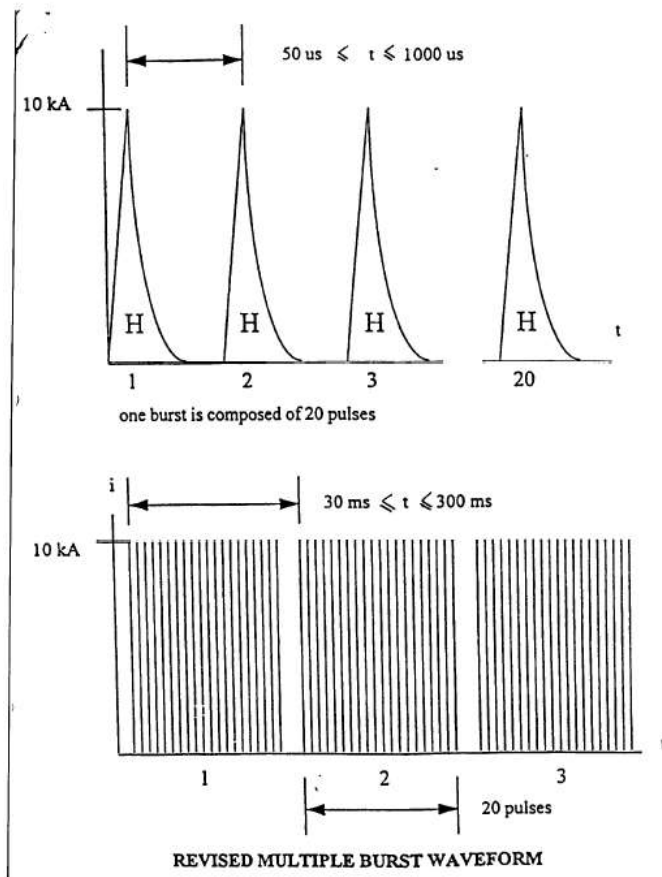

<sup>1</sup> JAA Interim Policy INT/POL/25/4 Issue 2 , dated 01-10-94 can be procured from commercial publishers such as IHS

<b>SPECIAL CONDITION</b>	<b>D-302: Lightning Protection Indirect Effects</b>
APPLICABILITY:	777-300, 777-200LR, 777-300ER, 777F
REQUIREMENTS:	JAR 25.581, 25X899, 25.954, 25.1309
ADVISORY MATERIAL:	N/A

Recent knowledge on severe and multiple lightning strike levels needs to be taken into consideration in establishing the acceptability of the provisions employed for the protection from indirect effects of lightning strike. According to JAA Interim Policy INT/POL/25/4 Issue 2<sup>2</sup>, dated 01-10-94, the following special condition should be applied:

"Each system whose failure to function properly would prevent the continued safe flight and landing of the aircraft, must be designed and installed to ensure that the aircraft can perform its intended function during and after exposure to lightning.

Each system whose failure to function properly would reduce the capacity of the airplane or the ability of the flight crew to cope with adverse operating conditions must be designed and installed to ensure that it can perform its intended function after exposure to lightning.

The lightning strike models to be used for system justification shall be as described in FAA AC 20-136 dated March 5, 1990 with the following modifications:

Appendix III of AC 20-136 defines the multiple burst lightning waveform. The revised waveform to be used instead, comprises repetitive Component waveforms in 3 sets of 20 pulses each as shown in Appendix 1. (see next page)

The minimum time between individual Component H Pulses within a burst is 50 ms, the maximum time is 1000 ms. The minimum time between subsequent bursts is 30 ms, and the maximum time is 300 ms."

APPENDIX 1 TO CRI D-302

Page 1/1

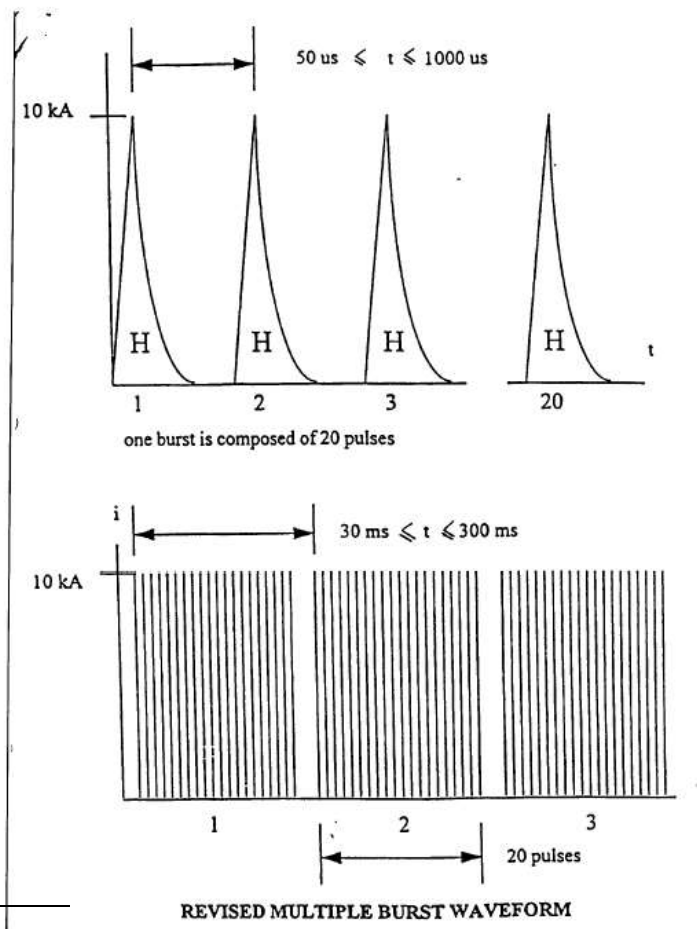

<sup>2</sup> JAA Interim Policy INT/POL/25/4 Issue 2 , dated 01-10-94 can be procured from commercial publishers such as IHS

<b>SPECIAL CONDITION</b>	<b>D-5: Protection from External High Intensity Radiated Fields</b>
APPLICABILITY:	777-200, (including „IGW“), 777-300, 777-200LR, 777-300ER, 777F
REQUIREMENTS:	JAR 25.1309(a), 25.1431
ADVISORY MATERIAL:	N/A

Recent knowledge on High Intensity Radiated Fields (HIRF) threat levels and probability, needs to be taken into consideration in establishing the acceptability of the HIRF protection employed.

Following Special Condition applies:

(a) The aeroplane systems and associated components, considered separately and in relation to other systems, must be designed and installed so that (see draft AMJ 25.1317 dated 17 January 1992):

- (1) Each system that perform a critical or essential function is not adversely affected when the aeroplane is exposed to the Normal HIRF Environment.
- (2) All critical functions must not be adversely affected when the aeroplane is exposed to the Certification HIRF Environment.
- (3) After the aeroplane is exposed to the Certification HIRF Environment, each affected system that performs a critical function recovers normal operation without requiring any crew action, unless this conflicts with other operational or functional requirements of that system.

(b) For the purpose of this section, the following definitions apply:

- (1) Critical function: a function whose failure would prevent the continued safe flight and landing of the aeroplane.
- (2) Essential function: a function whose failure would reduce the capability of the aeroplane of the ability of the crew to cope with adverse operating conditions.
- (3) The definitions of Normal and Certification HIRF Environment are found below:

#### The High Intensity Radiated Fields (HIRF) Environments

- a) The normal and Certification HIRF Environment frequency bands and corresponding average and peak levels are define in Table 1 and Table 2.
- b) The HIRF Environments are defined in terms of field strength in volts per meter versus the given frequency range.

Table 1 – see next page

Special Condition D-5 continued

Table 1

Certification HIRF Environment

Frequency	Field Strengths in Volts/Meter	
	Peak	Average
10 kHz - 100 kHz	40	40
100 kHz - 500 kHz	40	40
500 kHz - 2 MHz	40	40
2 MHz - 30 MHz	100	100
30 MHz - 70 MHz	20	20
70 MHz - 100 MHz	20	20
100 MHz - 200 MHz	50	30
200 MHz - 400 MHz	70	70
400 MHz - 700 MHz	730	30
700 MHz - 1 GHz	1300	70
1 GHz - 2 GHz	2500	160
2 GHz - 4 GHz	3500	240
4 GHz - 6 GHz	3200	280
6 GHz - 8 GHz	800	330
8 GHz - 12 GHz	3500	330
12 GHz - 18 GHz	1700	180

Note: At 10 kHz - 100 kHz a High Impedance Field of 320 V/m peak exists, AMJ 25.1317 should be referred to for the applicability of this environment.

Table 2

Normal HIRF Environment

Frequency	Field Strengths in Volts/Meter	
	Peak	Average
10 kHz - 100 kHz	20	20
100 kHz - 500 kHz	20	20
500 kHz - 2 MHz	30	30
2 MHz - 30 MHz	50	50
30 MHz - 70 MHz	10	10
70 MHz - 100 MHz	10	10
100 MHz - 200 MHz	30	30
200 MHz - 400 MHz	25	25
400 MHz - 700 MHz	730	30
700 MHz - 1 GHz	40	10
1 GHz - 2 GHz	1700	160
2 GHz - 4 GHz	3000	170
4 GHz - 6 GHz	2300	280
6 GHz - 8 GHz	530	230

<b>SPECIAL CONDITION</b>	<b>D-6: Lightning Protection Requirements</b>
APPLICABILITY:	777-200, (including „IGW“), 777-300, 777-200LR, 777-300ER
REQUIREMENTS:	JAR 25.581, 25X899, 25.954, 25.1333, 25.1431
ADVISORY MATERIAL:	N/A

The JAA Team considers that the FAA Special Condition against Lightning Protection Requirements, as introduced by FAA Issue Paper SE-2 dated 10-17-90<sup>3</sup> shall apply. Due consideration shall also be given to JAR 25X899 which does not have a direct FAR 25 equivalent.

A back-up copy of the 777 Special Condition repository is embedded and available upon request.



777 SC\_backup.pdf

---

<sup>3</sup> FAA Issue Papers can be retrieved in general from <http://rgl.faa.gov/> - subject Issue Paper is available in a larger repository at [http://rgl.faa.gov/Regulatory and Guidance Library/rgSC.nsf/WebSearchDefault?SearchView&Query=777%20lightning&SearchOrder=1&SearchMax=0&SearchWV=TRUE&SearchFuzzy=FALSE&Start=1&Count=100#](http://rgl.faa.gov/Regulatory_and_Guidance_Library/rgSC.nsf/WebSearchDefault?SearchView&Query=777%20lightning&SearchOrder=1&SearchMax=0&SearchWV=TRUE&SearchFuzzy=FALSE&Start=1&Count=100#)

<b>SPECIAL CONDITION</b>	<b>D-GEN01 PTC: Fire Resistance of Thermal Insulation Material</b>
APPLICABILITY:	777-200, (including „IGW“), 777-300, 777-200LR, 777-300ER
REQUIREMENTS:	CS25.856 & Appendix F
ADVISORY MATERIAL:	N/A

In the interests of harmonisation, EASA adopts wording for a Special Condition to CS25, identical to the text of FAR25.856(a) along with the test method specified in new Part VI to Appendix F as incorporated at FAR 25 amendment 25-111. The text for the new requirement is detailed below and appropriate guidance material to amend Appendix F of CS25 is included as Appendix 1 to this Special Condition.

New CS25.856:

“Thermal/acoustic insulation material installed in the fuselage must meet the flame propagation test requirements of part VI of Appendix F to CS25, or other approved equivalent test requirements. This requirement does not apply to "small parts," as defined in subpart I of Appendix F to CS25.”

Also, to maintain consistency with existing requirements, this special condition amends CS 25.853(a) and CS 25.855(d) as follows:

“ JAR 25.853 Compartment interiors.

(a) Except for thermal/acoustic insulation materials, materials (including finishes or decorative surfaces applied to the materials) must meet the applicable test criteria prescribed in part I of appendix F or other approved equivalent methods, regardless of the passenger capacity of the aeroplane. ”

“ JAR 25.855 Cargo or baggage compartments.

(d) Except for thermal/acoustic insulation materials, all other materials used in the construction of the cargo or baggage compartment must meet the applicable test criteria prescribed in part I of appendix F or other approved equivalent methods. ”

**Annex 1 to D-GEN01 PTC: Fire Resistance of Thermal Insulation Material**

Part 25 AIRWORTHINESS STANDARDS: TRANSPORT CATEGORY AIRPLANES	
Appendix F	

Sec. F25.6

[Appendix F--Part VI--Test Method To Determine the Flammability and Flame Propagation Characteristics of Thermal/Acoustic Insulation Materials]

[Use this test method to evaluate the flammability and flame propagation characteristics of thermal/acoustic insulation when exposed to both a radiant heat source and a flame.

(a) *Definitions.*

"Flame propagation" means the furthest distance of the propagation of visible flame towards the far end of the test specimen, measured from the midpoint of the ignition source flame. Measure this distance after initially applying the ignition source and before all flame on the test specimen is extinguished. The measurement is not a determination of burn length made after the test.

"Radiant heat source" means an electric or air propane panel.

"Thermal/acoustic insulation" means a material or system of materials used to provide thermal and/or acoustic protection. Examples include fiberglass or other batting material encapsulated by a film covering and foams.

"Zero point" means the point of application of the pilot burner to the test specimen.

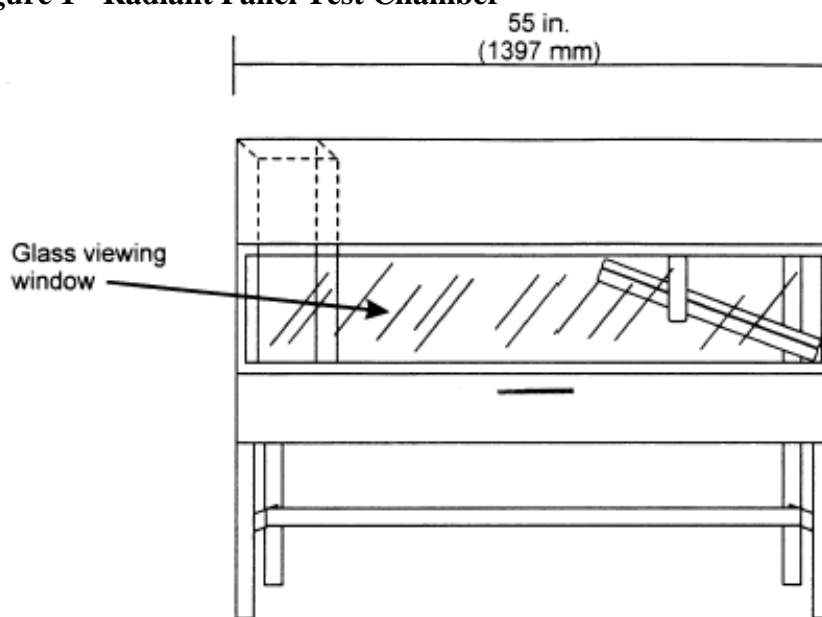
(b) *Test apparatus.***Figure 1 - Radiant Panel Test Chamber****Figure 1 - Radiant Panel Test Chamber**

(1) Radiant panel test chamber. Conduct tests in a radiant panel test chamber (see figure 1 above). Place the test chamber under an exhaust hood to facilitate clearing the chamber of smoke after each test. The radiant panel test chamber must be an enclosure 55 inches (1397 mm) long by 19.5 (495 mm) deep by 28 (710 mm) to 30 inches (maximum) (762 mm) above the test specimen. Insulate the sides, ends, and top with a fibrous ceramic insulation, such as Kaowool MTM board. On the front side, provide a 52 by 12-inch (1321 by 305 mm) draft-free, high-temperature, glass window for viewing the sample during testing. Place a door below the window to provide access to the movable specimen platform holder. The bottom of the test chamber must be a sliding steel platform that has provision for securing the test specimen holder in a fixed and level position. The chamber must have an internal chimney with exterior dimensions of 5.1 inches (129 mm) wide, by 16.2 inches (411 mm) deep by 13 inches (330 mm) high at the opposite end of the chamber from the radiant energy source. The interior dimensions must be 4.5 inches (114 mm) wide by 15.6 inches (395 mm) deep. The chimney must extend to the top of the chamber (see figure 2).

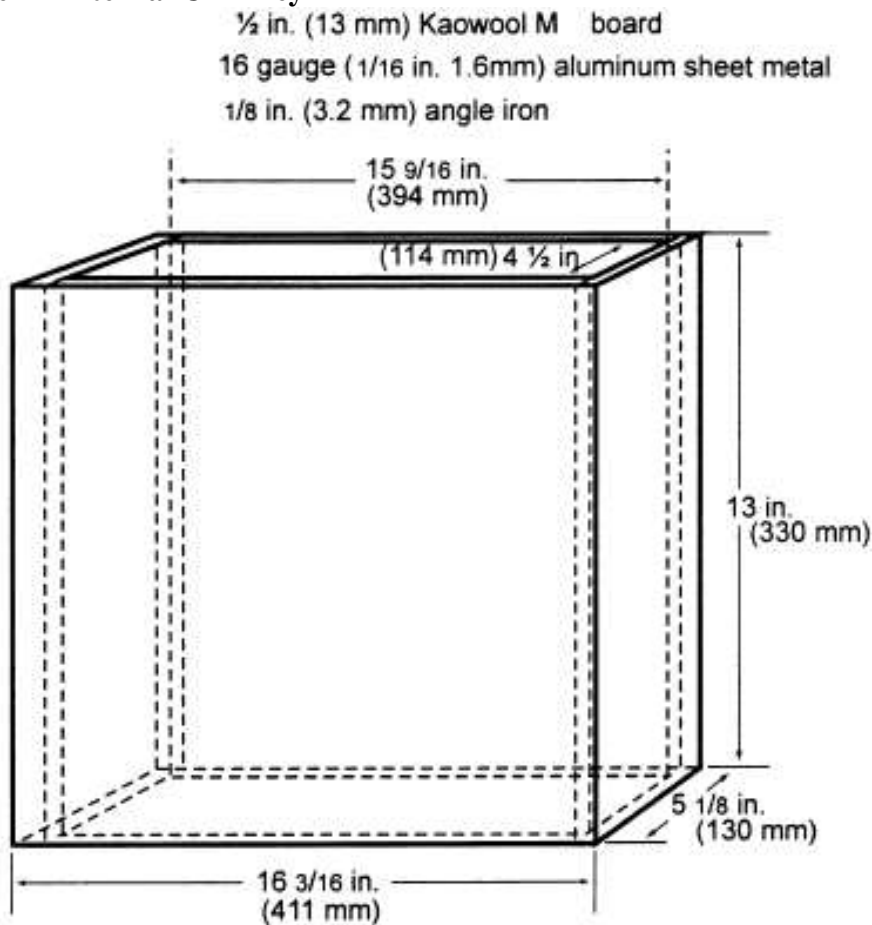

**Figure 2 - Internal Chimney****Figure 2 - Internal Chimney**

(2) Radiant heat source. Mount the radiant heat energy source in a cast iron frame or equivalent. An electric panel must have six, 3- inch wide emitter strips. The emitter strips must be perpendicular to the length of the panel. The panel must have a radiation surface of 12 7/8 by 18 1/2 inches (327 by 470 mm). The panel must be capable of operating at temperatures up to 1300 deg F (704 deg C). An air propane panel must be made of a porous refractory material and have a radiation surface of 12 by 18 inches (305 by 457 mm). The panel must be capable of operating at temperatures up to 1,500 deg F (816 deg C). See figures 3a and 3b.

Figure 3a -- Electric Panel

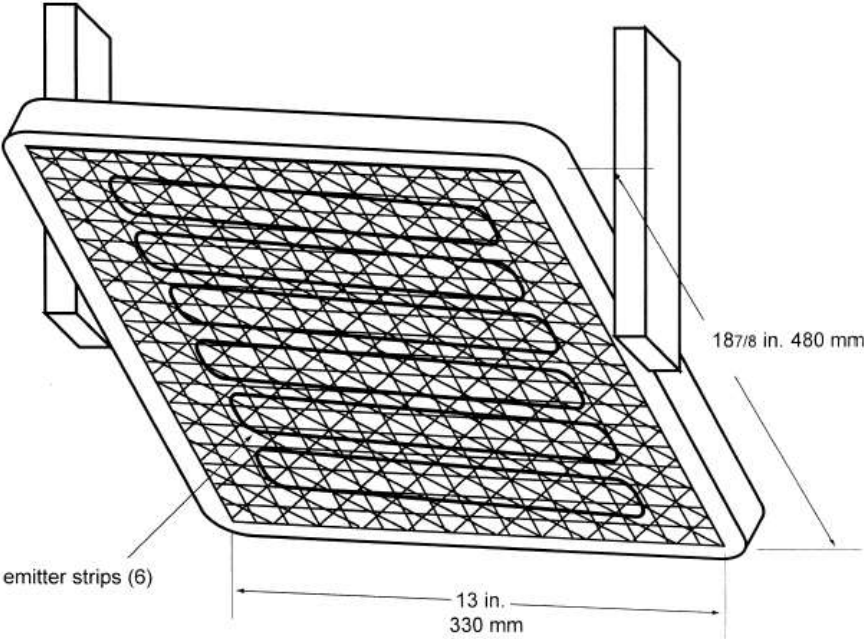

Figure 3a – Electric Panel

Figure 3b -- Air Propane Radiant Panel

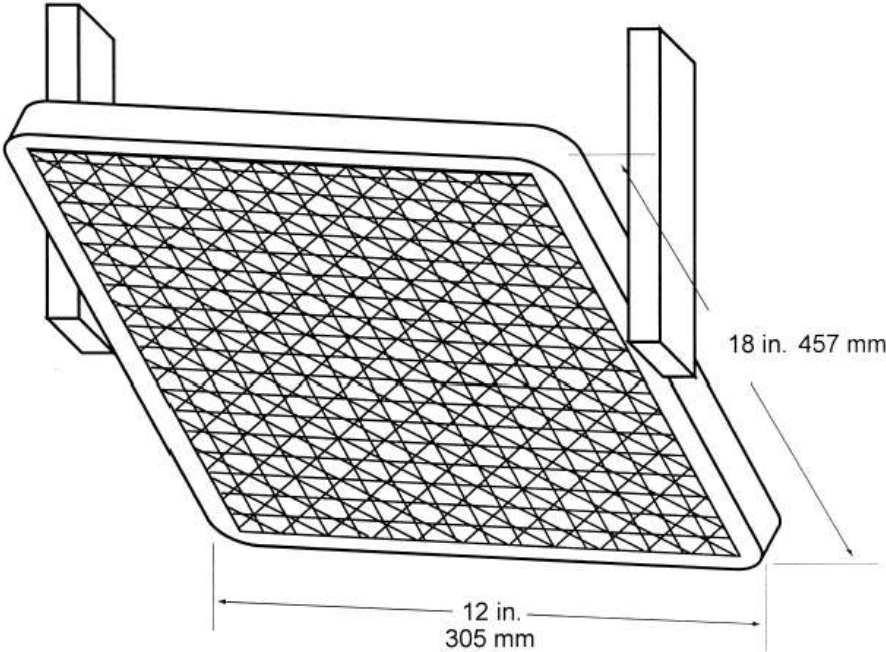

Figure 3b – Air Propane Radiant Panel

(i) Electric radiant panel. The radiant panel must be 3-phase and operate at 208 volts. A single-phase, 240 volt panel is also acceptable. Use a solid-state power controller and microprocessor-based controller to set the electric panel operating parameters.

(ii) Gas radiant panel. Use propane (liquid petroleum gas--2.1 UN 1075) for the radiant panel fuel. The panel fuel system must consist of a venturi-type aspirator for mixing gas and air at approximately atmospheric pressure. Provide suitable instrumentation for monitoring and controlling the flow of fuel and air to the panel. Include an air flow gauge, an air flow regulator, and a gas pressure gauge.

(iii) Radiant panel placement. Mount the panel in the chamber at 30 deg to the horizontal specimen plane, and

7 1/2 inches above the zero point of the specimen.

(3) Specimen holding system.

(i) The sliding platform serves as the housing for test specimen placement. Brackets may be attached (via wing nuts) to the top lip of the platform in order to accommodate various thicknesses of test specimens. Place the test specimens on a sheet of Kaowool MTM board or 1260 Standard Board (manufactured by Thermal Ceramics and available in Europe), or equivalent, either resting on the bottom lip of the sliding platform or on the base of the brackets. It may be necessary to use multiple sheets of material based on the thickness of the test specimen (to meet the sample height requirement). Typically, these non-combustible sheets of material are available in 1/4 inch (6 mm) thicknesses. See figure 4. A sliding platform that is deeper than the 2-inch (50.8mm) platform shown in figure 4 is also acceptable as long as the sample height requirement is met.

**Figure 4 -- Sliding Platform**

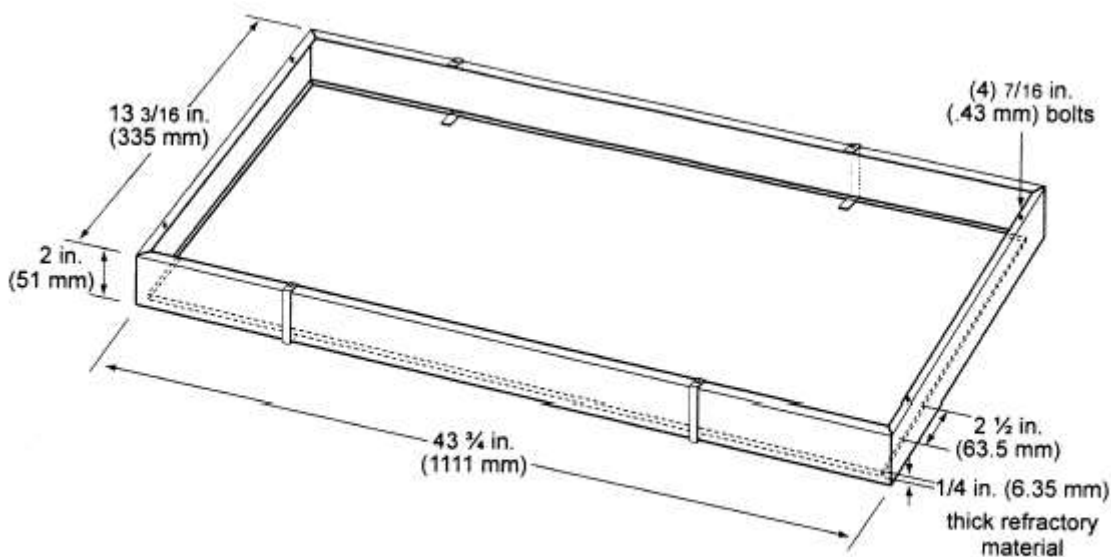
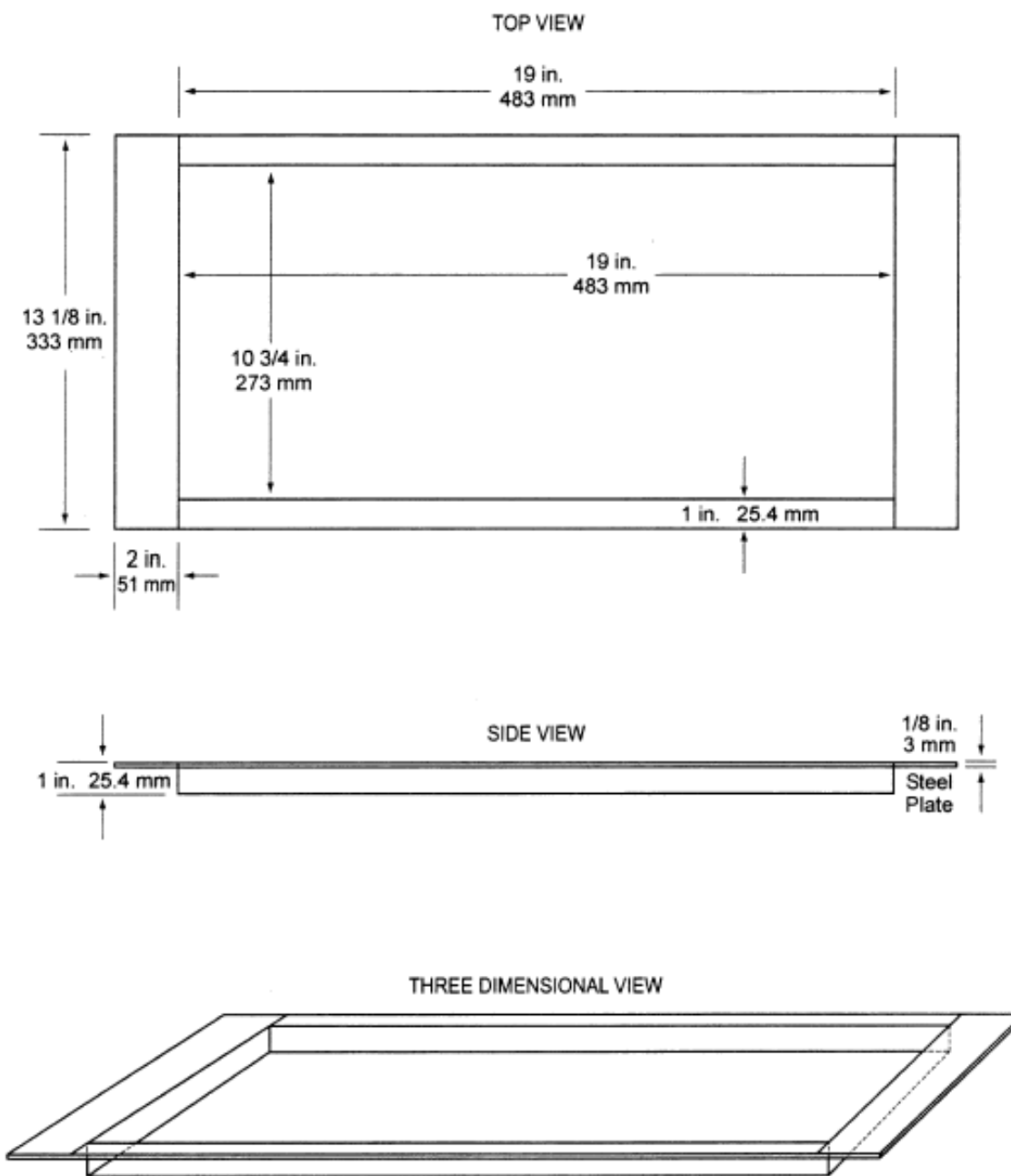

**Figure 4 - Sliding Platform**

(ii) Attach a 1/2 inch (13 mm) piece of Kaowool MTM board or other high temperature material measuring 41 1/2 by 8 1/4 inches (1054 by 210 mm) to the back of the platform. This board serves as a heat retainer and protects the test specimen from excessive preheating. The height of this board must not impede the sliding platform movement (in and out of the test chamber). If the platform has been fabricated such that the back side of the platform is high enough to prevent excess preheating

of the specimen when the sliding platform is out, a retainer board is not necessary.  
 (iii) Place the test specimen horizontally on the non-combustible board(s). Place a steel retaining/securing frame fabricated of mild steel, having a thickness of 1/8 inch (3.2 mm) and overall dimensions of 23 by 13 1/8 inches (584 by 333 mm) with a specimen opening of 19 by 10 3/4 inches (483 by 273 mm) over the test specimen. The front, back, and right portions of the top flange of the frame must rest on the top of the sliding platform, and the bottom flanges must pinch all 4 sides of the test specimen. The right bottom flange must be flush with the sliding platform. See figure 5.

**Figure 5: 3 views**



**Figure 5: 3 views**

(4) Pilot Burner. The pilot burner used to ignite the specimen must be a Bernzomatic™ commercial propane venturi torch with an axially symmetric burner tip and a propane supply tube with an orifice diameter of 0.006 inches (0.15 mm). The length of the burner tube must be 2 7/8 inches (71 mm). The propane flow must be adjusted via gas pressure through an in-line regulator to produce a blue inner cone length of 3/4 inch (19 mm). A 3/4 inch (19 mm) guide (such as a thin strip of metal) may be soldered to the top of the burner to aid in setting the flame height. The overall flame length must be approximately 5 inches long (127 mm). Provide a way to move the burner out of the ignition position so that the flame is horizontal and at least 2 inches (50 mm) above the specimen plane. See figure 6.

**Figure 6 -- Propane Pilot Burner**

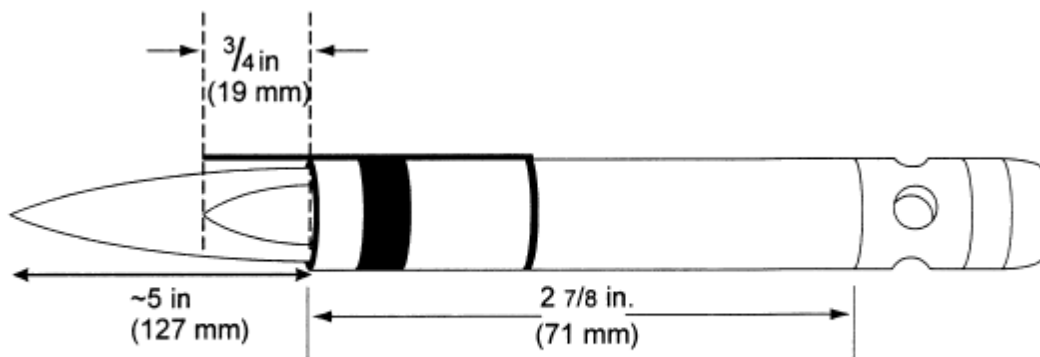

Figure 6 – Propane Pilot Burner

(5) Thermocouples. Install a 24 American Wire Gauge (AWG) Type K (Chromel-Alumel) thermocouple in the test chamber for temperature monitoring. Insert it into the chamber through a small hole drilled through the back of the chamber. Place the thermocouple so that it extends 11 inches (279 mm) out from the back of the chamber wall, 11 1/2 inches (292 mm) from the right side of the chamber wall, and is 2 inches (51 mm) below the radiant panel. The use of other thermocouples is optional.

(6) Calorimeter. The calorimeter must be a one-inch cylindrical water-cooled, total heat flux density, foil type Gardon Gage that has a range of 0 to 5 BTU/ft<sup>2</sup>-second (0 to 5.7 Watts/cm<sup>2</sup>).

(7) Calorimeter calibration specification and procedure.

(i) Calorimeter specification.

(A) Foil diameter must be 0.25 +/-0.005 inches (6.35 +/-0.13 mm).

(B) Foil thickness must be 0.0005 +/-0.0001 inches (0.013 +/- ;0.0025 mm).

(C) Foil material must be thermocouple grade Constantan.

(D) Temperature measurement must be a Copper Constantan thermocouple.

(E) The copper center wire diameter must be 0.0005 inches (0.013 mm).

(F) The entire face of the calorimeter must be lightly coated with "Black Velvet" paint having an emissivity of 96 or greater.

(ii) Calorimeter calibration.

(A) The calibration method must be by comparison to a like standardized transducer.

(B) The standardized transducer must meet the specifications given in paragraph VI(b)(6) of this appendix.

(C) Calibrate the standard transducer against a primary standard traceable to the National Institute

of Standards and Technology (NIST).

(D) The method of transfer must be a heated graphite plate.

(E) The graphite plate must be electrically heated, have a clear surface area on each side of the plate of at least 2 by 2 inches (51 by 51 mm), and be 1/8 inch +/- 1/16 inch thick (3.2 +/- 1.6 mm).

(F) Center the 2 transducers on opposite sides of the plates at equal distances from the plate.

(G) The distance of the calorimeter to the plate must be no less than 0.0625 inches (1.6 mm), nor greater than 0.375 inches (9.5 mm).

(H) The range used in calibration must be at least 0-3.5 BTUs/ ft<sup>2</sup> second (0-3.9 Watts/cm<sup>2</sup>) and no greater than 0-5.7 BTUs/ ft<sup>2</sup> second (0-6.4 Watts/cm<sup>2</sup>).

(I) The recording device used must record the 2 transducers simultaneously or at least within 1/10 of each other.

(8) Calorimeter fixture. With the sliding platform pulled out of the chamber, install the calorimeter holding frame and place a sheet of non-combustible material in the bottom of the sliding platform adjacent to the holding frame. This will prevent heat losses during calibration. The frame must be 13 1/8 inches (333 mm) deep (front to back) by 8 inches (203 mm) wide and must rest on the top of the sliding platform. It must be fabricated of 1/8 inch (3.2 mm) flat stock steel and have an opening that accommodates a 1/2 inch (12.7 mm) thick piece of refractory board, which is level with the top of the sliding platform. The board must have three 1-inch (25.4 mm) diameter holes drilled through the board for calorimeter insertion. The distance to the radiant panel surface from the centerline of the first hole ("zero" position) must be 7 1/2 +/- 1/8 inches (191 +/- 3 mm). The distance between the centerline of the first hole to the centerline of the second hole must be 2 inches (51 mm). It must also be the same distance from the centerline of the second hole to the centerline of the third hole. See figure 7. A calorimeter holding frame that differs in construction is acceptable as long as the height from the centerline of the first hole to the radiant panel and the distance between holes is the same as described in this paragraph.

**Figure 7 - Calorimeter Holding Frame**

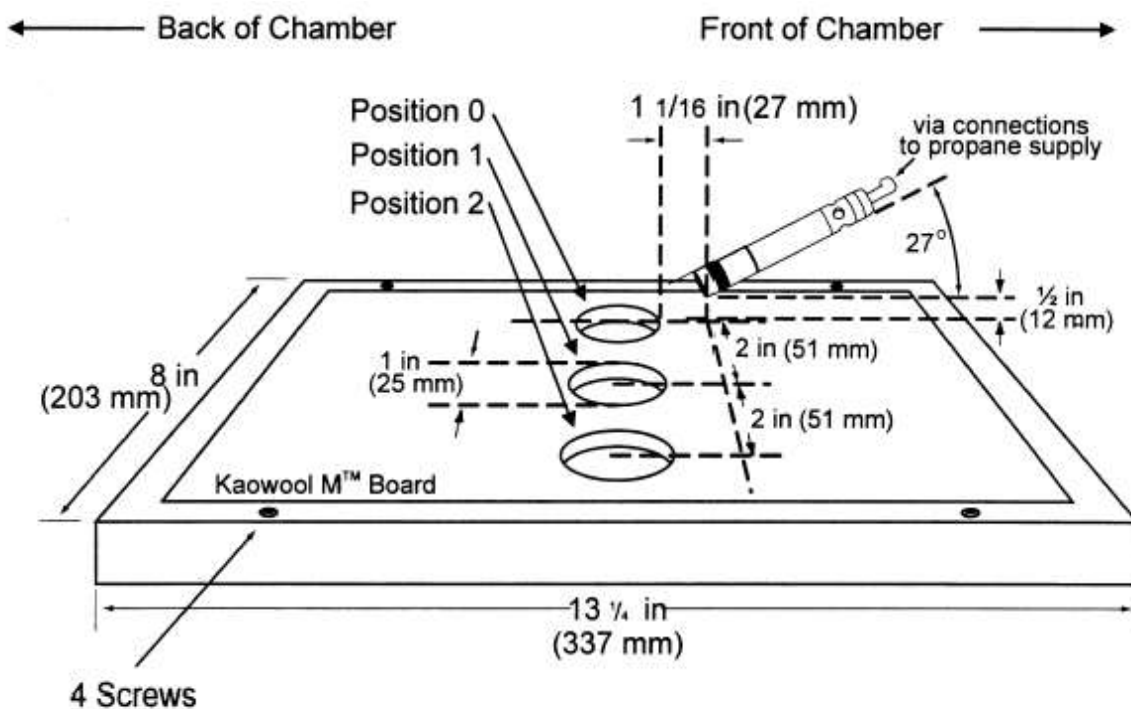

**Figure 7 - Calorimeter Holding Frame**

(9) Instrumentation. Provide a calibrated recording device with an appropriate range or a computerized data acquisition system to measure and record the outputs of the calorimeter and the thermocouple. The data acquisition system must be capable of recording the calorimeter output every second during calibration.

(10) Timing device. Provide a stopwatch or other device, accurate to +/-1 second/hour, to measure the time of application of the pilot burner flame.

(c) Test specimens.

(1) Specimen preparation. Prepare and test a minimum of three test specimens. If an oriented film cover material is used, prepare and test both the warp and fill directions.

(2) Construction. Test specimens must include all materials used in construction of the insulation (including batting, film, scrim, tape etc.). Cut a piece of core material such as foam or fiberglass, and cut a piece of film cover material (if used) large enough to cover the core material. Heat sealing is the preferred method of preparing fiberglass samples, since they can be made without compressing the fiberglass ("box sample"). Cover materials that are not heat sealable may be stapled, sewn, or taped as long as the cover material is over-cut enough to be drawn down the sides without compressing the core material. The fastening means should be as continuous as possible along the length of the seams. The specimen thickness must be of the same thickness as installed in the airplane.

(3) Specimen Dimensions. To facilitate proper placement of specimens in the sliding platform housing, cut non-rigid core materials, such as fiberglass, 12 1/2 inches (318mm) wide by 23 inches (584mm) long. Cut rigid materials, such as foam, 11 1/2 +/- 1/4 inches (292 mm +/- 6mm) wide by 23 inches (584mm) long in order to fit properly in the sliding platform housing and provide a flat, exposed surface equal to the opening in the housing.

(d) Specimen conditioning. Condition the test specimens at 70 +/- 5 deg F (21 +/- 2 deg C) and 55% +/- 10% relative humidity, for a minimum of 24 hours prior to testing.

(e) Apparatus Calibration.

(1) With the sliding platform out of the chamber, install the calorimeter holding frame. Push the platform back into the chamber and insert the calorimeter into the first hole ("zero" position). See figure 7. Close the bottom door located below the sliding platform. The distance from the centerline of the calorimeter to the radiant panel surface at this point must be 7. 1/2 inches +/- 1/8 (191 mm +/- 3). Prior to igniting the radiant panel, ensure that the calorimeter face is clean and that there is water running through the calorimeter.

(2) Ignite the panel. Adjust the fuel/air mixture to achieve 1.5 BTUs/ft<sup>2</sup>-second +/- 5% (1.7 Watts/cm<sup>2</sup> +/- 5%) at the "zero" position. If using an electric panel, set the power controller to achieve the proper heat flux. Allow the unit to reach steady state (this may take up to 1 hour). The pilot burner must be off and in the down position during this time.

(3) After steady-state conditions have been reached, move the calorimeter 2 inches (51 mm) from the "zero" position (first hole) to position 1 and record the heat flux. Move the calorimeter to position 2 and record the heat flux. Allow enough time at each position for the calorimeter to stabilize. Table 1 depicts typical calibration values at the three positions.

**Table 1.--Calibration Table**

Position	BTU's/ft <sup>2</sup> sec	Watts/cm <sup>2</sup>
"Zero" Position	1.5	1.7
Position 1	1.51-1.50-1.49	1.71-1.70-1.69
Position 2	1.43-1.44	1.62-1.63

(4) Open the bottom door, remove the calorimeter and holder fixture. Use caution as the fixture is very hot.

(f) Test Procedure.

(1) Ignite the pilot burner. Ensure that it is at least 2 inches (51 mm) above the top of the platform. The burner must not contact the specimen until the test begins.

(2) Place the test specimen in the sliding platform holder. Ensure that the test sample surface is level with the top of the platform. At "zero" point, the specimen surface must be 7 1/2 inches +/- 1/8 inch (191 mm +/- 3) below the radiant panel.

(3) Place the retaining/securing frame over the test specimen. It may be necessary (due to compression) to adjust the sample (up or down) in order to maintain the distance from the sample to the radiant panel (7 1/2 inches +/- 1/8 inch (191 mm +/- 3) at "zero" position). With film/fiberglass assemblies, it is critical to make a slit in the film cover to purge any air inside. This allows the operator to maintain the proper test specimen position (level with the top of the platform) and to allow ventilation of gases during testing. A longitudinal slit, approximately 2 inches (51mm) in length, must be centered 3 inches +/- 1/2 inch (76mm +/- 13mm) from the left flange of the securing frame. A utility knife is acceptable for slitting the film cover.

(4) Immediately push the sliding platform into the chamber and close the bottom door.

(5) Bring the pilot burner flame into contact with the center of the specimen at the "zero" point and simultaneously start the timer. The pilot burner must be at a 27 deg angle with the sample and be approximately 1/2 inch (12 mm) above the sample. See figure 7. A stop, as shown in figure 8, allows the operator to position the burner correctly each time.

### **Figure 8 -- Propane Burner Stop**



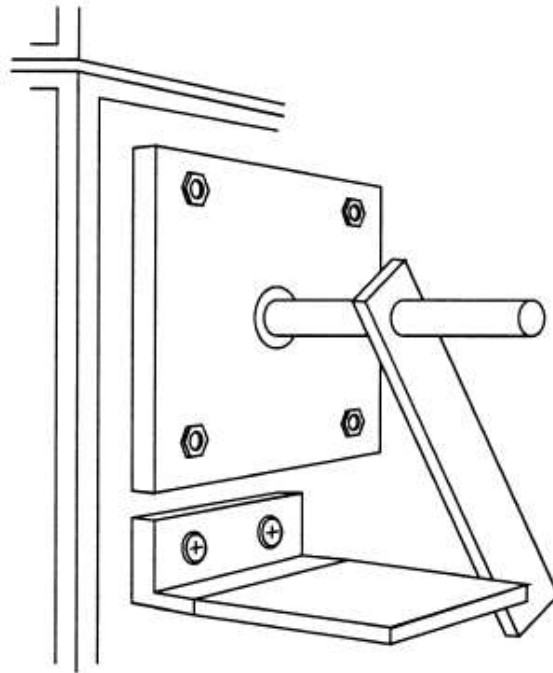

Figure 8 - Propane Burner Stop

(6) Leave the burner in position for 15 seconds and then remove to a position at least 2 inches (51 mm) above the specimen.

(g) Report.

(1) Identify and describe the test specimen.

(2) Report any shrinkage or melting of the test specimen.

(3) Report the flame propagation distance. If this distance is less than 2 inches, report this as a pass (no measurement required).

(4) Report the after-flame time.

(h) Requirements.

(1) There must be no flame propagation beyond 2 inches (51 mm) to the left of the centerline of the pilot flame application.

(2) The flame time after removal of the pilot burner may not exceed 3 seconds on any specimen.]

Amdt. 25-111, Eff. 9/2/2003

<b>SPECIAL CONDITION</b>	<b>D-GEN02 PTC Application of heat release and smoke density requirements to seat materials</b>
APPLICABILITY:	777-200, (including „IGW“), 777-300, 777-200LR, 777-300ER
REQUIREMENTS:	CS 25.853(d) Appendix F Part IV & V Part 21 §21A.16B
ADVISORY MATERIAL:	N/A

1. Except as provided in paragraph 3 of these special conditions, compliance with JAR 25, Appendix F, parts IV and V, heat release and smoke emission, is required for seats that incorporate non- traditional, large, non-metallic panels that may either be a single component or multiple components in a concentrated area in their design.
2. The applicant may designate up to and including 0.13935 m<sup>2</sup> (1.5 square feet) of non-traditional, non-metallic panel material per seat place that does not have to comply with special condition Number 1, above. A triple seat assembly may have a total of 0.41805 m<sup>2</sup> (4.5 square feet) excluded on any portion of the assembly (e.g., outboard seat place 0.0929 m<sup>2</sup> (1 square foot), middle 0.0929 m<sup>2</sup> (1 square foot), and inboard 0.23225 m<sup>2</sup> (2.5 square feet)).
3. Seats do not have to meet the test requirements of JAR 25, Appendix F, parts IV and V, when installed in compartments that are not otherwise required to meet these requirements. Examples include:
  - a. Airplanes with passenger capacities of 19 or less and
  - b. Airplanes exempted from smoke and heat release requirements.
4. Only airplanes associated with new seat certification programs applied for after the effective date of these special conditions will be affected by the requirements in these special conditions. This Special Condition is not applicable to:
  - a. the existing airplane fleet and follow-on deliveries of airplanes with previously certified interiors,
  - b. For minor layout changes and major layout changes of already certified versions that:
    - ◆ does not affect seat design;
    - ◆ does not introduce changes to seat design that affect panels that could be defined as “non- traditional, large, non-metallic panels”.

<b>EQUIVALENT SAFETY FINDING</b>	<b>D-GEN7 Flammability Testing Hierarchy</b>
APPLICABILITY:	777-200LR/-300ER
REQUIREMENTS:	JAR/CS 25.853(a)
ADVISORY MATERIAL:	N/A

Similarly with the ELoS granted by FAA in FAA IP C-5, an Equivalent Safety Finding with flammability requirements applicable as per 25.853(a) can be achieved by showing that the same panel construction meets heat release rate requirements of CS-25 Appendix F Part IV.

Panels that according to CS 25.853 are required to be tested per Appendix F Parts I, IV and V need only be tested per Parts IV and V. The data generated to meet the requirements of Appendix F Part IV for a certain panel can be used to substantiate compliance with CS 25.853(a) for the same panel.

The applicant is requested to specify in flammability test plans and reports the reference to the heat release test data that are considered adequate to substantiate compliance with CS 25.853(a).

<b>SPECIAL CONDITION</b>	<b>F-02: Access to Class E Cargo Compartments in Flight</b>
APPLICABILITY:	B777F
REQUIREMENTS:	JAR 25.855, 25.857, 25.1309, 25.1439, 25.1443
ADVISORY MATERIAL:	N/A

1. Portable oxygen equipment readily accessible in the courier compartment, must be provided for the maximum number of supernumeraries allowed to access the class E cargo compartment in-flight. The equipment shall meet JAR 25.1439 (b) and JAR 25.1443 (e).
2. Occupant accessing the Class E cargo compartment must be trained in the use of portable oxygen equipment.
3. Number of occupant accessing the Class E cargo compartment at the same time is restricted to the number of readily available portable oxygen equipment.
4. Aural and visual means, readily detectable from any accessible location in the Class E cargo compartment, must be provided to warn any occupant who may be present in the Class E cargo compartment when to don the oxygen equipment and /or when a return to seat is required.
5. A means or a procedure must be provided to allow each flight crew to assess, from his/her seat, when the Class E cargo compartment is occupied.
6. The AFM must include clear instructions:
  - a. to define fire fighting procedures in the Class E cargo compartment in particular for the case of fire while the cargo compartment is being accessed,
  - b. to require that portable oxygen equipment be carried by an occupant each time the cargo compartment is accessed
7. Placards must be installed on each in-flight access door instructing that:
  - a. smoking is not allowed at all time during access.
  - b. door must be kept closed (except during the actual in-flight access period).
  - c. portable oxygen equipment be carried each time the cargo compartment is accessed by an occupant.

Equivalent Safety Finding	F-GEN 9-1: Minimum Mass Flow of Supplemental Oxygen "Component Qualification"
APPLICABILITY:	777-200, (including „IGW“), 777-300, 777-200LR, 777-300ER
REQUIREMENTS:	JAR25.1443(c)
ADVISORY MATERIAL:	N/A

EASA has reviewed FAA Issue Paper S-1, which defines the basis for an Equivalent Safety Finding. EASA has adopted this issue paper in CRI F-GEN9-1.

The FAA Transport Airplane Directorate (TAD) has assigned a unique ELOS memorandum number TS13-0005-S-1 to facilitate archiving and retrieval of this ELOS. This memorandum provides standardized documentation of the ELOS finding that is non-proprietary and can be made available to the public.

It is available here:

[http://rgl.faa.gov/Regulatory\\_and\\_Guidance\\_Library/rgELOS.nsf/0/5D50708317ED2A5B86257C40005D0790?OpenDocument](http://rgl.faa.gov/Regulatory_and_Guidance_Library/rgELOS.nsf/0/5D50708317ED2A5B86257C40005D0790?OpenDocument)

A back-up copy is embedded in this document and available upon request



TS13-0005--S-1\_ESF  
on 25.1443.pdf

<b>Equivalent Safety Finding</b>	<b>F-GEN 9-3: Crew Determination of Quantity of Oxygen in Passenger Oxygen System</b>
APPLICABILITY:	777-200, (including „IGW“), 777-300, 777-200LR, 777-300ER
REQUIREMENTS:	JAR25.1441(c)
ADVISORY MATERIAL:	N/A

- 1) A detailed description of the design details must be provided to describe the compensating features which provide an equivalent level of safety.
- 2) The oxygen supply source is designed and tested to ensure that it will retain its required quantity of oxygen or chemicals throughout its expected life limit under foreseeable operating conditions.
- 3) A means is provided for maintenance to readily determine when oxygen is no longer available in the supply source due to inadvertent activation.
- 4) The life limit of the oxygen supply source is established by test and analysis.
- 5) Each oxygen supply source is labelled such that the expiration date can be easily determined by maintenance.
- 6) Boeing defines maintenance and inspection procedures in the maintenance planning documents to ensure that the oxygen supply source
  - a. that are discharged are removed from the airplane,
  - b. are not installed on the airplane past their expiration date.
- 7) Each oxygen supply source does not supply oxygen to more than six oxygen masks.

<b>SPECIAL CONDITION</b>	<b>H-01: Enhanced Airworthiness Programme for Aeroplane Systems – ICA on EWIS</b>
APPLICABILITY:	B717, B727, B737, B747, B757, B767, B777, DC-10, MD 11, DC-8, DC-9, MD-80, MD 90 (all FAR 26.11 affected models)
REQUIREMENTS:	PART 21A.16B(a)(3), 21A.3B(c)(1), CS 25.1529 & Appendix H
ADVISORY MATERIAL:	AMC 25 Subpart H

Add to: **Appendix H Instructions for Continued Airworthiness**

### **H25.5 Electrical Wiring Interconnection Systems Instructions for Continued Airworthiness**

The applicant must prepare Instructions for Continued Airworthiness (ICA) applicable to Electrical Wiring Interconnection System (EWIS) as defined below that include the following:

Maintenance and inspection requirements for the EWIS developed with the use of an enhanced zonal analysis procedure (EZAP) that includes:

- a. Identification of each zone of the aeroplane.
- b. Identification of each zone that contains EWIS.
- c. Identification of each zone containing EWIS that also contains combustible materials.
- d. Identification of each zone in which EWIS is in close proximity to both primary and back-up hydraulic, mechanical, or electrical flight controls and lines.
- e. Identification of –
  - Tasks, and the intervals for performing those tasks, that will reduce the likelihood of ignition sources and accumulation of combustible material, and
  - Procedures, and the intervals for performing those procedures, that will effectively clean the EWIS components of combustible material if there is not an effective task to reduce the likelihood of combustible material accumulation.
- f. Instructions for protections and caution information that will minimize contamination and accidental damage to EWIS, as applicable, during the performance of maintenance, alteration, or repairs.

The ICA must be in the form of a document appropriate for the information to be provided, and they must be easily recognizable as EWIS ICA.

For the purpose of this Appendix H25.5, the following EWIS definition applies:

- (a) Electrical wiring interconnection system (EWIS) means any wire, wiring device, or combination of these, including termination devices, installed in any area of the aeroplane for the purpose of transmitting electrical energy, including data and signals between two or more intended termination points. Except as provided for in subparagraph (c) of this paragraph, this includes:
  - (1) Wires and cables.
  - (2) Bus bars.
  - (3) The termination point on electrical devices, including those on relays, interrupters, switches, contactors, terminal blocks, and circuit breakers and other circuit protection devices.

---

Special Condition H-01 continued

- (4) Connectors, including feed-through connectors.
  - (5) Connector accessories.
  - (6) Electrical grounding and bonding devices and their associated connections.
  - (7) Electrical splices.
  - (8) Materials used to provide additional protection for wires, including wire insulation, wire sleeving, and conduits that have electrical termination for the purpose of bonding.
  - (9) Shields or braids.
  - (10) Clamps and other devices used to route and support the wire bundle.
  - (11) Cable tie devices.
  - (12) Labels or other means of identification.
  - (13) Pressure seals.
- (b) The definition in subparagraph (a) of this paragraph covers EWIS components inside shelves, panels, racks, junction boxes, distribution panels, and back-planes of equipment racks, including, but not limited to, circuit board back-planes, wire integration units and external wiring of equipment.
- (c) Except for the equipment indicated in subparagraph (b) of this paragraph, EWIS components inside the following equipment, and the external connectors that are part of that equipment, are excluded from the definition in subparagraph (a) of this paragraph:
- (1) Electrical equipment or avionics that is qualified to environmental conditions and testing procedures when those conditions and procedures are -
    - (i) Appropriate for the intended function and operating environment, and
    - (ii) Acceptable to the Agency.
  - (2) Portable electrical devices that are not part of the type design of the aeroplane. This includes personal entertainment devices and laptop computers.
  - (3) Fibre optics.

- END -