

This document was created to make public non-proprietary data contained in Special Conditions (including Deviations, Equivalent Safety Findings) that are part of the applicable Certification Basis as recorded in TCDS EASA.A.015.

Table of Content:

A-01-CCD: CABIN CREW DATA REQUIREMENTS	4
A-1: DISCRETE GUST REQUIREMENTS	8
A-2: INTERACTION OF SYSTEMS AND STRUCTURE	9
A-3: DESIGN MANOEUVRE REQUIREMENTS	10
A-4: DESIGN DIVE SPEED VD	13
A-5: LIMIT PILOT FORCES AND TORQUE	15
A-7: STALLING SPEEDS FOR STRUCTURAL DESIGN	16
A-11: AEROELASTIC STABILITY REQUIREMENTS	17
A-1001: REVISED LOADS REQUIREMENTS	20
A-1002: INTERACTION OF SYSTEMS AND STRUCTURE	32
A-1003: DESIGN MANOEUVRE REQUIREMENTS	37
A-1004: DESIGN DIVE SPEED VD	39
A-1006: GROUND LOADS AND CONDITIONS FOR CENTRAL LANDING GEAR	41
A-1011: VIBRATION, BUFFET AND AEROELASTIC STABILITY REQUIREMENTS	44
A-1015: CHECKED PITCHING MANOEUVRE LOADS	47
A-1017: BRAKED ROLL CONDITIONS	50
A-1020: LANDING GEAR SHOCK ABSORPTION TESTS	52
A-1021: ENGINE FAILURE LOADS	54
A-1023: CONTINUOUS TURBULENCE LOADS	56
A-1024: CASTING FACTORS	61
A-1026: PROOF OF STRUCTURE	67
CCD-01: DETERMINATION OF CERTIFICATION BASIS FOR CHANGES TO A340 CCD	68
D-100: INSTALLATION OF MINI-SUITE TYPE SEATING	70
D-101: GREEN ARROW AND "OPEN" PLACARD FOR EMERGENCY EXIT MARKING	73
D-102: INCORPORATION OF INERTIA LOCKING DEVICE IN DYNAMIC SEATS	75
E-2: UNDERFLOOR CREW REST COMPARTMENT	78
E-5.1: LOWER DECK LAVATORIES COMPARTMENT	81
E-8.1: LOWER DECK STOWAGE AREA	86
E-11: BULK CREW REST COMPARTMENT	91
E-15: REINFORCED SECURITY COCKPIT DOOR STATUS	94
E-17: TROLLEY LIFT	97
E-18: LOWER DECK GALLEY COMPARTMENT	99
E-19: FIRST CLASS SLIDING SCREENS	101
E-21: EMERGENCY EXIT MARKING REFLECTANCE	104
E-27: FORWARD FACING SEAT, OVER 18 DEGREES TO A/C CENTRELINE	105
E-28: PARTIAL BULK CREW REST COMPARTMENT WITH ATTACHED GALLEY	107
E-29: FUSELAGE BURN THROUGH – AFT PRESSURE BULKHEAD	109

Disclaimer – This document is not exhaustive and it will be updated gradually.



E-30: FUSELAGE BURNTROUGH SUBSTANTIATION FOR BELLY FAIRING	112
E-31: FUSELAGE BURNTROUGH SUBSTANTIATION FOR BILGE AREA	114
E-128: IMPROVED FLAMMABILITY STANDARD FOR THERMAL/ACOUSTIC INSULATION MATERIALS – FLAME PENETRATION (EQUIVALENT TO FAR 25.856(B) AT AMENDMENT 111)	116
E-130: APPLICATION OF HEAT RELEASE AND SMOKE DENSITY REQUIREMENTS TO SEAT MATERIALS	131
E-134: INSTALLATION OF SEATS THAT MAKE AN ANGLE OF MORE THAN 18° WITH THE AIRCRAFT LONGITUDINAL AXIS	132
E-1014: HIC COMPLIANCE FOR FRONT ROW SEATING(INFLATABLE RESTRAINTS)	134
E-1022: IMPROVED FLAMMABILITY STANDARDS FOR THERMAL/ACOUSTIC INSULATION MATERIALS	138
E-1023: SIDE FACING SEATS WITH INFLATABLE RESTRAINTS	140
F-1: STALLING AND SCHEDULED OPERATING SPEEDS	144
F-2: MOTION AND EFFECT OF COCKPIT CONTROLS	152
F-3: STATIC LONGITUDINAL STABILITY	153
F-4: STATIC DIRECTIONAL AND LATERAL STABILITY	154
F-5: FLIGHT ENVELOPE PROTECTIONS	155
F-6: NORMAL LOAD FACTOR LIMITING SYSTEM	157
F-8: ACCELERATE STOP DISTANCES	158
F-8.1: ACCELERATE STOP DISTANCES AND RELATED PERFORMANCE	161
F-126: FLIGHT RECORDERS INCLUDING DATA LINK RECORDING	167
F-128: MINIMUM MASS FLOW OF SUPPLEMENTAL OXYGEN	169
F-129: CREW DETERMINATION OF QUANTITY OF OXYGEN IN PASSENGER OXYGEN SYSTEM	170
F-131: FLIGHT INSTRUMENT EXTERNAL PROBES – QUALIFICATION IN ICING CONDITIONS	172
F-137: SECURITY PROTECTION OF AIRCRAFT SYSTEMS AND NETWORKS	176
F-GEN-01: INSTALLATION OF NON-RECHARGEABLE LITHIUM BATTERY	178
F-1001: STALLING AND SCHEDULED OPERATING SPEEDS	180
F-1003: STATIC LONGITUDINAL STABILITY AND LOW ENERGY AWARENESS	187
F-1008: ACCELERATE STOP DISTANCES	188
F-1014: REVISION OF GATE REQUIREMENTS FOR HIGH-LIFT DEVICE CONTROLS	195
G-5: RESISTANCE TO FIRE TERMINOLOGY	196
G-7: FUNCTION AND RELIABILITY TESTING	197
H-01: ENHANCED AIRWORTHINESS PROGRAMME FOR AEROPLANE SYSTEMS - ICA ON EWIS	198
O-1001: FERRYING ONE ENGINE UNSERVICEABLE	201
P-1: FADEC	207
P-2: CENTRE OF GRAVITY CONTROL SYSTEM	208
P-27: FLAMMABILITY REDUCTION SYSTEM	211
P-32: FUEL TANK SAFETY	216
P-1008: FUEL TANK ACCESS COVERS	218

Disclaimer – This document is not exhaustive and it will be updated gradually.



---

P-1009: ROLLS-ROYCE TRENT 500 TURBINE OVERHEAT DETECTION	219
P-1011: THRUST REVERSER TESTING	220
P-1016: REAR CENTER TANK & TYRE FAILURE	222
P-1018: ENGINE SUSTAINED IMBALANCE	224
P-1020: APU INSTRUMENTS	226
P-1021: WINDMILLING WITHOUT OIL	227
P-1022: FALLING AND BLOWING SNOW	228
P-1024: ECAMEGT INDICATION	230
S-3: LANDING GEAR WARNING	232
S-6: LIGHTNING PROTECTION INDIRECT EFFECTS	234
S-10: EFFECT OF EXTERNAL RADIATION UPON AIRCRAFT SYSTEMS	236
S-10.1: EFFECT OF EXTERNAL RADIATION UPON AIRCRAFT SYSTEMS	238
S-10.2: EFFECT OF EXTERNAL RADIATION UPON AIRCRAFT SYSTEMS	241
S-13: AUTO-THRUST SYSTEM	244
S-16: CONTROL SIGNAL INTEGRITY	245
S-18: ELECTRICAL FLIGHT CONTROLS UNUSUAL FEATURES	246
S-20: EMERGENCY ELECTRICAL POWER	247
S-21: BRAKES WEAR LIMITS	248
S-23: MISCELLANEOUS ELECTRICAL REQUIREMENTS	252
S-24: DOORS	254
S-38: TOWBARLESS TOWING	255
S-45: OIL TEMPERATURE INDICATION	256
S-48: MINIMUM APPROACH BREAK-OFF HEIGHT	257
S-148: LONGITUDINAL TOUCHDOWN PERFORMANCE LIMIT AND MINIMUM APPROACH BREAK-OFF HEIGHT	259
S-1013: AUTO-THRUST SYSTEM (ATS)	261
S-1021: BRAKES AND BRAKING SYSTEM	262
S-1059: HYDRAULIC SYSTEMS	266
S-1065: PACKS OFF OPERATION	269
S-1066: CAT III OPERATIONS - EXCESS DEVIATION ALERT	271
S-1070 ESF: AFM - RVR LIMITS	273

Disclaimer – This document is not exhaustive and it will be updated gradually.



## A-01-CCD: CABIN CREW DATA REQUIREMENTS

<b>SPECIAL CONDITION</b>	<b>A-01-CCD: Cabin Crew Data Requirements</b>
APPLICABILITY:	A330 / A340
REQUIREMENTS:	Regulation (EU) 748/2012 of 03 August 2012, as amended
ISSUE:	1 dated 10/12/2015

### Special Condition summary

#### BACKGROUND

The purpose of this CRI is to establish the certification basis for the grandfathered A330/-340 aircraft family Cabin Crew Operational Suitability Data.

There were no applicable certification specifications for operational suitability data issued in accordance with point 21.A.16A, effective on the date of the Type Certificate application for the A330-200/-300; A340-200/-300; A340-500; A340-600.

In accordance with Part 21, 21.A.17B (a), the operational suitability data certification basis needs to be defined for the A330/-340 aircraft Family Cabin Crew Operational Suitability Data, transferred from the “A330/-340 Family -OEB Cabin Crew Evaluation Report”.

The purpose of the (J) OEB CC evaluations, as requested by Airbus, was to:

- determine whether the A340-600 is a variant of the A340-300 (as per JAR-OPS 1.1030- Operation on more than one type or variant);
- determine whether the A330-200/-300; the A340-500; the A340-600 are variants of the A340-200/-300 (as per JAR-OPS 1.1030- Operation on more than one type or variant), thus constituting the “A330/340 family”;
- provide recommendations to support the establishment by operators, of cabin crew differences training programs for variants (as per JAR-OPS 1.1010 – Conversion and differences training).

NOTE: See also certification basis complement CCD-01 (published in this document), that comes in addition to the present SC A-01-CCD.

#### SPECIAL CONDITION

Disclaimer – This document is not exhaustive and it will be updated gradually.



Having regard of the applicable JAR-OPS 1 requirements and in accordance with "Part 3-Procedure Document for Joint Operational Evaluation Board (JOEB)-Cabin Crew", which governed the (J) OEB CC evaluations, the following aircraft type specific elements that would impact normal and/or emergency operations for cabin crew were compared and assessed, in order to fulfil the purpose of the evaluations:

- aircraft configuration:
  - number of aisles
  - number of passenger decks
- doors and exits
  - exit arming/disarming
  - direction of movement of the operating handle
  - direction of exit opening
  - power assist mechanism

Note: In accordance with JAR-OPS 1.1030/EU-OPS 1.1030 and later on with ORO.CC.250, self-help exits, for example Type III and Type IV exits, need not to be included in the determination of new type or variant.

- assisting evacuation means
- aircraft systems for cabin crew duties:
  - emergency lighting system
  - smoke detection system
  - built-in fire extinguishing system
  - drop-down oxygen system
  - communication and public address system
  - control and indication panels

Using the above categories as criteria, detailed Operator Differences Tables(ODRs) – the Airbus equivalent of Aircraft Differences Tables (ADTs) – were provided by Airbus, in order to highlight the exiting differences between the A340-200/-300 as the “base” aircraft and the A330-200/-300; the A340-500, the A340-600 as the “candidate” aircraft within the comparisons.

The ODRs also include recommended levels of cabin crew training associated to the levels of complexity of the identified differences between the base and the candidate aircraft.

The outcome of the A330/-340 aircraft family (J) OEB CC evaluations confirmed that for cabin crew, the A330-200/-300; the A340-500; the A340-600, are variants of the A340-200/-300 (as per JAR-OPS1.1030, and later on, in accordance with the EU-OPS 1.1030 and ORO.CC.250). As such, cabin crew differences training would be required when transferring from one aircraft to another, in order to ensure compliance at the operator level, with JAR-OPS 1.1010, and later on with EU OPS 1.1010 and ORO.CC 130.

Disclaimer – This document is not exhaustive and it will be updated gradually.



As contained in the ODRs, Levels of training varying from Level 1 to Level 3, were identified as adequate in order to cover the design differences identified between the “base” and the “candidate” aircraft.

Difference Levels

The following is an excerpt from Chapter 4 – Difference Levels for Training and Checking of the EASA OEB Handbook, Part III- Draft Procedures Document for Cabin Crew Subgroup, version 4 of 19th July 2006, and defines the different levels of training.

<b>Difference level</b>	<b>Training</b>	<b>Checking</b>
<b>1</b>	Self-Instruction (Written information)	Not applicable
<b>2</b>	Aided Instruction (CBT, Video.)	Applicable as required
<b>3</b>	Hands-on Training (Training Device, or Aircraft)	Applicable

Level 1:

Applicable to aircraft with differences that can be adequately addressed through self-instruction. Level 1 training represents a knowledge requirement such that, once appropriate information is provided, understanding and compliance can be assumed to take place. Compliance with Level 1 training is typically achieved by methods such as issuance of operating manual page revisions, dissemination of cabin crew operating bulletins or differences hand-outs to describe minor differences between aircraft.

Level 2:

Applicable to aircraft with systems or procedural differences that can be adequately addressed through aided instruction. At Level 2, aided instruction is appropriate to ensure crew understanding, emphasise issues, provide a standardised method of presentation of material, or to aid retention of material following training. Level 2 aided instruction typically employs such means as slide/tape presentations, computer based training (CBT), stand-up lectures or videotapes.

Level 3:

Applicable to aircraft with differences that can only be addressed through use of devices capable of system training (i.e. hands-on training) Training devices are required to supplement instruction to ensure attainment or retention of crew skills and abilities to accomplish the more complex tasks, usually related to operation of particular aircraft systems. Typical training devices for Level 3 would include emergency evacuation procedures trainers, fire and smoke trainers, cabin crew panel trainers etc. When dedicated trainers are not available, Level 3 would require hands-on training using the aircraft.

Disclaimer – This document is not exhaustive and it will be updated gradually.



In addition to the transfer of the A330/-340 OEB CC Report to A330/-340 Cabin Crew Operational Suitability Data compliance documentation, and in response to the Commission Regulation No 69/2014, Airbus and EASA have agreed on the Airbus proposed division of the operational suitability data in mandatory data (M) and non-mandatory data (AMC = Acceptable Means of Compliance), as highlighted in the compliance documentation.

As per the Commission Regulation (EU) No 69/2014, Article 7a, para.3, the elements identified in accordance with the JAA procedures (described above), shall be included in the relevant type-certificate and shall be deemed to constitute the A330/A340 aircraft family cabin crew operational suitability data.

NOTE: See also certification basis complement CCD-01 (published in this document), that comes in addition to the present SC A-01-CCD.

### Acronyms and Abbreviations

<b>ADT</b>	Aircraft Differences Tables
<b>CBT</b>	Computer Based Training
<b>CCD</b>	Cabin Crew Data
<b>JAR</b>	Joint Aviation Regulation
<b>JOEB-CC</b>	Joint Operational Evaluation Board (JOEB)-Cabin Crew
<b>ODR</b>	Operator Differences Tables
<b>OSD</b>	Operational Suitability Data

Disclaimer – This document is not exhaustive and it will be updated gradually.





## A-1: DISCRETE GUST REQUIREMENTS

<b>SPECIAL CONDITION</b>	<b>A-1: Discrete Gust Requirements</b>
APPLICABILITY:	A330 / A340
REQUIREMENTS:	JAR 25.305 (c), JAR 25.341, JAR 25.351(b)
ISSUE:	4 dated 23/11/1992

### Special Condition summary

## BACKGROUND

The dynamic response to vertical and lateral tuned discrete gust must be taken into account.

## SPECIAL CONDITION

The applicable discrete gust requirements consist of:

- 1) The requirements of JAR 25 paragraphs 25.305(c), 25.341 Gust and Turbulence loads, 25.351(b) as modified by OP 91-1.
- 2) JAR 25.341(a) modified to read:

JAR 25.341(a)

## Acronyms and Abbreviations

<b>JAR</b>	Joint Aviation Regulation
<b>OP</b>	Orange Paper

Disclaimer – This document is not exhaustive and it will be updated gradually.





## A-2: INTERACTION OF SYSTEMS AND STRUCTURE

<b>SPECIAL CONDITION</b>	<b>A-2: Interaction of systems and structure</b>
APPLICABILITY:	A330 / A340
REQUIREMENTS:	JAR 25 subpart C and D
ISSUE:	2 dated 12/04/1991

### Special Condition summary

#### BACKGROUND

The A330 and A340 are equipped with systems which directly or as a result of failure or malfunction affect their structural performance. There is a need to develop interpretative material of existing requirements of JAR 25 subpart C and D to account for these new features.

The NPA 25C-199 based on A320 special condition has been issued to that purpose.

It is proposed to use the NPA (issue 6 of March 7, 1990) as a basis for a special condition with a few amendments.

#### SPECIAL CONDITION

Add a new paragraph 25.302 reading:

##### **25.302 Interaction of systems and structures**

For an aircraft equipped with systems which directly or as a result of a failure or malfunction affect its structural performance, the influence of these systems and their failure conditions shall be taken into account in showing compliance with the requirements of Subpart C and D.

#### Acronyms and Abbreviations

<b>JAR</b>	Joint Aviation Regulation
<b>NPA</b>	Notice of Proposed Amendment

Disclaimer – This document is not exhaustive and it will be updated gradually.



### A-3: DESIGN MANOEUVRE REQUIREMENTS

SPECIAL CONDITION	A-3: Design manoeuvre requirements
APPLICABILITY:	A330 / A340
REQUIREMENTS:	JAR 25.331(c)(1), 25.331(c)(2), 25.349(a), 25.351
ISSUE:	2 dated 12/04/1991

#### Special Condition summary

### BACKGROUND

The existing requirements for design manoeuvres need to be modified because they are not adequate for an aircraft with electronic flight controls.

### SPECIAL CONDITION

**Replace JAR 25.331 paragraph (c)(1) and (c)(2) by:**

(c)(1) Maximum elevator displacement at  $V_A$

The aeroplane is assumed to be flying in steady level flight (point A1 within the manoeuvring envelope of JAR 25.333(b) and except as limited by pilot effort in accordance with JAR 25.397(b) the cockpit pitching control device is suddenly moved to obtain extreme positive pitching acceleration (nose up). In defining the tail load condition the response of the aeroplane may be taken into account. Loads occurring beyond the point in time where no acceleration at the CG nz exceeds the maximum positive limit manoeuvring factor may be ignored.

(c)(2) Checked manoeuvre between  $V_A$  and  $V_D$

A checked manoeuvre, based on a rational cockpit pitching control device motion versus time profile must be established in which the design limit load factor specified in JAR 25.337 will not be exceeded.

**Add to JAR 25.331 (c) paragraph (c)(3):**

(c)(3) Manoeuvre loads induced by the system

It must be established that manoeuvre loads induced by the system itself (e.g. abrupt changes in orders made possible by electric rather than mechanical combination of different inputs) are acceptably accounted for.

**Replace JAR 25.349(a) by:**

(a) Manoeuvring: The following conditions, speeds and cockpit roll control motions (except as the motions may be limited by pilot effort) must be considered in combination with an aeroplane load

Disclaimer – This document is not exhaustive and it will be updated gradually.



factor of zero and the two-thirds of limit positive manoeuvring load factor. In determining the resulting control surface deflections the torsional flexibility of the wing must be considered in accordance with JAR 25.301(b):

- (1) Conditions corresponding to maximum steady rolling velocities and conditions corresponding to maximum angular accelerations must be investigated. For the angular acceleration conditions zero rolling velocity may be assumed in the absence of a rational time history investigation of the manoeuvre.
- (2) At  $V_A$  movement of the cockpit roll control up to the limit is assumed. The position of the cockpit roll control must be maintained until a steady roll rate is achieved and then must be returned suddenly to the neutral position.
- (3) At  $V_C$  the cockpit roll control must be moved suddenly and maintained so as to achieve a roll rate not less than that obtained in sub-paragraph (2) of this paragraph.
- (4) At  $V_D$  the cockpit roll control must be moved suddenly and maintained so as to achieve a roll rate not less than one third of that obtained in sub-paragraph (2) of this paragraph.
- (5) It must be established that manoeuvre loads induced by the system itself (i.e. abrupt changes in orders made possible by electrical rather than mechanical combination of different inputs) are acceptably accounted for.

**Amend paragraph JAR 25.351 as follows:**

The aeroplane must be designed for loads resulting from the conditions specified in sub-paragraphs (a) and (b) of this paragraph. Unbalanced aerodynamic moments about the centre of gravity must be reacted in a rational or conservative manner considering the principal masses furnishing the reacting inertia forces:

(a) Manoeuvring: At speeds from  $V_{MC}$  to  $V_D$ , the following manoeuvres must be considered. In computing the tail loads, the yawing velocity may be assumed to be zero. Physical limitations of the aircraft from the cockpit yaw control device to the control surface deflection, such as control stop position, maximum power and displacement rate of the servo controls, control law limiters may be taken into account.

- (1) With the aeroplane in unaccelerated flight at zero yaw, it is assumed that the cockpit yaw control device (pedal) is suddenly displaced (with critical rate) to the maximum deflection, as limited by the stops.
- (2) With the cockpit yaw control device (pedal) deflected as specified in sub-paragraph (1) of this paragraph, it is assumed that the aeroplane yaws to the resulting sideslip angle.

Disclaimer – This document is not exhaustive and it will be updated gradually.



---

(3) With the aeroplane yawed to the static sideslip angle with the cockpit yaw control deflected as in sub-paragraph (1) of this paragraph, it is assumed that the cockpit yaw control device is returned to neutral.

### Acronyms and Abbreviations

<b>JAR</b>	Joint Aviation Regulation
<b>CG</b>	Centre of Gravity

Disclaimer – This document is not exhaustive and it will be updated gradually.



## A-4: DESIGN DIVE SPEED VD

SPECIAL CONDITION	A-4: Design dive speed VD
APPLICABILITY:	A330 / A340
REQUIREMENTS:	JAR 25.335(b)(1) and (b)(2)
ISSUE:	4 dated 17/01/1991

### Special Condition summary

## BACKGROUND

The A330/A340 is equipped with a high speed protection system which limits nose down pilot authority at speeds above  $V_C/M_C$ . The requirement of JAR 25.335(b)(1) must therefore be adapted for  $V_D$  selection.

## SPECIAL CONDITION

### Modify JAR 25.335(b) to read:

(b) Design Dive speed  $V_D$ .  $V_D$  must be selected so that  $V_C/M_C$  is not greater than  $0.8 V_D/M_D$ , or so that the minimum speed margin between  $V_C/M_C$  and  $V_D/M_D$  is the greater of the following values:

(1) The speed increase above  $V_C/M_C$  resulting from the following manoeuvres:

(i) From an initial condition of stabilized flight at  $V_C/M_C$ , the aeroplane is upset so as to take up a new flight path  $7.5^\circ$  below the initial path. Control application, up to full authority, is made to try and maintain this new flight path. Twenty seconds after initiating the upset manual recovery is made at a load factor of 1.5 g (0.5 g acceleration increment), or such greater load factor that is automatically applied by the system with the pilot's pitch control neutral. The speed increase occurring in this manoeuvre may be calculated, if reliable or conservative aerodynamic data is used. Power as specified in JAR 25.175(b)(1)(iv) is assumed until recovery is made, at which time power reduction and the use of pilot controlled drag devices may be assumed.

(ii) From a speed below  $V_C/M_C$ , with power to maintain stabilized level flight at this speed the aeroplane is upset so as to accelerate through  $V_C/M_C$  at a flight path  $15^\circ$  below the initial path (or at the steepest nose down attitude that the system will permit with full control authority if less than  $15^\circ$ ).

Note: Pilots controls may be in neutral position after reaching  $V_C/M_C$  and before recovery is initiated.

Recovery may be initiated 3 seconds after operation of high speed, attitude or other alerting system by application of a load factor of 1.5 g (0.5 g acceleration increment), or such greater

Disclaimer – This document is not exhaustive and it will be updated gradually.



load factor that is automatically applied by the system with the pilot's pitch control neutral. Power may be reduced simultaneously.

All other means of decelerating the aeroplane, the use of which is authorized up to the highest speed reached in the manoeuvre, may be used. The interval between successive pilot actions must not be less than one second.

(2) The minimum speed margin must be enough to provide for atmospheric variations (such as horizontal gusts, and penetration of jet streams and cold fronts) and for instruments errors and airframe production variations. These factors may be considered on a probability basis. However, the margin at altitude where  $M_C$  is limited by compressibility effects may not be less than .05 M. (see ACJ 25.335(b)(2)).

### Acronyms and Abbreviations

<b>JAR</b>	Joint Aviation Regulation
<b>ACJ</b>	Advisory Circular Joint

Disclaimer – This document is not exhaustive and it will be updated gradually.



## A-5: LIMIT PILOT FORCES AND TORQUE

<b>SPECIAL CONDITION</b>	<b>A-5: Limit pilot forces and torque</b>
APPLICABILITY:	A330 / A340
REQUIREMENTS:	JAR 25.397 (c)
ISSUE:	2 dated 17/01/1991

### Special Condition summary

#### BACKGROUND

The A330 / A340 aircraft models are equipped, with a side stick instead of a conventional control stick. The requirement of JAR 25.397(c) is therefore not adequate and must be replaced by a special condition.

#### SPECIAL CONDITION

For the A330 / A340 equipped with stick controls designed for forces to be applied by one wrist and not arms, the limit pilot forces are as follows:

- 1) For all components between and including the handle and its control stops.

PITCH	ROLL
Nose up 200 lb f.	Nose left 100 lb f.
Nose down 200 lb f.	Nose right 100 lb f.

- 2) For all other components of the Side stick control assembly, but excluding the internal components of the electrical sensor assemblies, to avoid damage as a result of an in-flight jam.

PITCH	ROLL
Nose up 125 lb f.	Nose left 50 lb f.
Nose down 125 lb f.	Nose right 50 lb f.

#### Acronyms and Abbreviations

<b>JAR</b>	Joint Aviation Regulation
------------	---------------------------

Disclaimer – This document is not exhaustive and it will be updated gradually.





## A-7: STALLING SPEEDS FOR STRUCTURAL DESIGN

<b>SPECIAL CONDITION</b>	<b>A-7: Stalling speeds for structural design</b>
APPLICABILITY:	A330 / A340
REQUIREMENTS:	JAR 25.331, 25.333, 25.335, 25.479, 25.481, 25.729
ISSUE:	2 dated 17/01/1991

### Special Condition summary

#### BACKGROUND

The A330/A340 is fitted with a stall protection system. The conventional stall speed  $V_s$  which is used to determine structural design airspeeds cannot be determined as on conventional aircraft. The problem was solved by using  $V_s = 0.94 V_{s1g}$ ,  $V_{s1g}$  being the stalling speed corrected to 1-g conditions.

#### SPECIAL CONDITION

For the structural design purposes, the stalling speeds in the following paragraphs have been redefined:

JAR 25.333	use $.94 V_{s1g}$ in lieu of $V_{s1}$ in manoeuvring envelope diagram
JAR 25.335	use $.94 V_{s1g}$ in lieu of $V_{s0}$ and $V_{s1}$
JAR 25.335(c) and (d)	use $.94 V_{s1g}$ in lieu of $V_{s1}$ and $V_{s0}$
JAR 25.335(e)	use $.94 V_{s1g}$ in lieu of $V_{s1}$ and $V_{s0}$
JAR 25.479(a)	use $.94 V_{s1g}$ in lieu of $V_{s0}$
JAR 25.481(a)(1)	use $.94 V_{s1g}$ in lieu of $V_{s1}$ and $V_{s0}$
JAR 25.729(a)(1)(ii)	use $.94 V_{s1g}$ in lieu of $V_{s1}$ and $V_s$

#### Acronyms and Abbreviations

<b>JAR</b>	Joint Aviation Regulation
------------	---------------------------

Disclaimer – This document is not exhaustive and it will be updated gradually.



## A-11: AEROELASTIC STABILITY REQUIREMENTS

<b>SPECIAL CONDITION</b>	<b>A-11: Aeroelastic stability requirements</b>
APPLICABILITY:	A330 / A340
REQUIREMENTS:	JAR 25.629
ISSUE:	4 dated 09/10/1992

### Special Condition summary

## BACKGROUND

The aeroelastic stability requirements are in the process of being amended both by the FAA (ref.to NPRM 89-24) and by the JAA. The NPRM is now agreed with several amendments by the JAR structure study group and is therefore proposed as a special condition for the A330 / A340 aircraft models.

## SPECIAL CONDITION

### (a) General

The aeroelastic stability evaluations required under this section include flutter, divergence, control reversal and any undue loss of stability and control as a result of structural deformation. The aeroelastic evaluation must include whirl modes associated with any rotating device that contributes significant dynamic forces. Compliance must be shown by analysis, ground vibration tests and flight tests.

### (b) Aeroelastic stability envelope

The aeroplane must be designed to be free from aeroelastic instability for all configurations and design conditions within the aeroelastic stability envelopes as follows:

- (1) For normal conditions without failures, malfunctions or adverse conditions, all combinations of altitudes and speeds encompassed by the  $V_D/M_D$  versus altitude envelope enlarged at all points by an increase of 15% in equivalent airspeed at both constant Mach number and constant altitude. In addition, a proper margin of stability must exist at all speeds up to  $V_D/M_D$  and, there must be no large and rapid reduction in stability as  $V_D/M_D$  is approached. The enlarged envelope may be limited to Mach 1.0 when  $M_D$  is less than 1.0 at all design altitudes and,
- (2) For the conditions described in paragraph (d) below, for all approved altitudes, any airspeed up to the greater airspeed defined by:
  - (i) The  $V_D/M_D$  envelope defined by JAR 25.335(b) or,
  - (ii) An altitude-airspeed envelope defined by a 15% increase in equivalent airspeed above  $V_C$  at constant altitude, from sea level to the altitude of the intersection of  $1.15 V_C$  with the extension of the constant cruise Mach number line,  $M_C$ , then a linear variation in equivalent

Disclaimer – This document is not exhaustive and it will be updated gradually.



airspeed to  $M_{C+.05}$  at the altitude of the lowest  $V_C/M_C$  intersection; then at higher altitudes, up to the maximum flight altitude, the boundary defined by a .05 Mach increase in  $M_C$  at constant altitude.

**(c) Balance weights**

If balance weights are used, their effectiveness and strength, including support structure, must be substantiated.

**(d) Failures, malfunctions, and adverse conditions**

The aeroplane must be shown to be free from any aeroelastic instability that would preclude continued safe flight and landing within the fail-safe envelope described in paragraph (b)(2) of this section for each of the failures described in (d)(3) of this section.

- (1) Safety following the failures, malfunctions or adverse conditions of paragraph (d)(3) may be substantiated by showing that losses in rigidity or changes in frequency, mode shape or damping are within the parameter investigations.
- (2) The damage tolerance requirements of JAR 25.571(b) must be used as a basis of evaluation to determine whether or not a structural element should be treated under the single failure criteria of (d)(3)(iv) or (d)(3)(v).
- (3) The damages, failures, malfunctions, and adverse conditions which must be considered in showing compliance with this section are:
  - (i) Any critical fuel loading conditions, not shown to be extremely improbable, which may result from mismanagement of fuel.
  - (ii) Any single failure in any passive flutter damping system.
  - (iii) The maximum likely accumulation of ice expected in service.
  - (iv) Failure of any single element of the structure supporting any engine, large auxiliary power unit, or large externally mounted aerodynamic body (such as external fuel tank).
  - (v) For aeroplanes with engines that have large rotating devices capable of significant dynamic forces, any single failure of the engine structure that would reduce the pitch or yaw rigidity of the rotational axis.
  - (vi) The absence of aerodynamic or gyroscopic forces resulting from the most adverse combination of rotating devices capable of significant dynamic forces. In addition, the effect of a single rotating device must be coupled with the failures of paragraphs (d)(3)(iv) and (d)(3)(v) of this section.
  - (vii) Any single rotating device capable of significant dynamic forces rotating at the highest likely overspeed.
  - (viii) Any failure or malfunction, or combination thereof, in the flight control system considered under JAR 25.671, 25.672, and 25.1309. However, any failure or malfunction of control systems where the displacement of movables is actively controlled by a system

Disclaimer – This document is not exhaustive and it will be updated gradually.



reacting on the relative displacement of the aeroplane or part of the aeroplane must be addressed.

(ix) Any damage or failure condition required or selected for investigation by JAR 25.571 or 25.631, and,

(x) Any other combination of failures, malfunctions, or adverse conditions not shown to be extremely improbable.

**(e) Flight flutter testing**

Full scale flight flutter tests at speeds up to  $V_{DF}/M_{DF}$  must be conducted for new type designs and for modifications to a type design unless they have been shown to have an insignificant effect on the aeroelastic stability. These tests must demonstrate that the aeroplane has a proper margin of damping at all speeds up to  $V_{DF}/M_{DF}$ , and that there is no large and rapid reduction in damping as  $V_{DF}/M_{DF}$  is approached. If a failure, malfunction, or adverse condition is simulated during flight test in showing compliance with paragraph (d) of this section, the maximum speed investigated need not exceed  $V_{FC}/M_{FC}$  if it is shown, by correlation of the flight test data with other test data or analyses, that the aeroplane is free from any aeroelastic instability at all speeds within the altitude - airspeed envelope described in paragraph (b) (2) of this section.

**Acronyms and Abbreviations**

<b>JAR</b>	Joint Aviation Regulation
<b>NPRM</b>	New Proposal Rule Making
<b>FAA</b>	Federal Aviation Administration
<b>JAA</b>	Joint Aviation Authorities

Disclaimer – This document is not exhaustive and it will be updated gradually.



## A-1001: REVISED LOADS REQUIREMENTS

SPECIAL CONDITION	A-1001: Revised Loads Requirements
APPLICABILITY:	A340-500 / -600
REQUIREMENTS:	JAR 25.305, 25.321, 25.331, 25.333, 25.335, 25.341, 25.343, 25.345, 25.349, 25.351, 25.371, 25.373, 25.391, 25.415, 25.427, 25.445, 25.473, 25.479, 25.481, 25.483, 25.485, 25.491, 25.499, 25.511, 25.561, 25.571, 25x1517
ISSUE:	2 dated 30/10/2000

### Special Condition summary

## BACKGROUND

The applicable Joint Certification Basis for A340-500 / -600 is JAR 25 change 14 plus JAR Amendment 25/96/1 which brings the JAR 25 certification basis up to the level of JAR 25 Amendment 81 for loads.

The use of NPA 25C -282 “Discrete gust rule changes” would align the JAR 25 certification basis with FAR amendment 25-86 for the discrete gust requirement.

The use of NPA 25C-260 “Structural Loads requirements” would align the JAR 25 certification basis with FAR amendment 25-91 for various loads paragraphs.

## SPECIAL CONDITION

### 1) (NPA 25C-282) Amend subparagraph (d) to JAR 25.305 to read as follows:

(d) [Reserved]

### 2) (NPA 25C-282) Amend subparagraphs (c) and (d) to paragraph JAR 25.321 reading as follows:

(c) Enough points on and within the boundaries of the design envelope must be investigated to ensure that the maximum load for each part of the aeroplane structure is obtained.

(d) The significant forces acting on the aeroplane must be placed in equilibrium in a rational or conservative manner. The linear inertia forces must be considered in equilibrium with the thrust and all aerodynamic loads, while the angular (pitching) inertia forces must be considered in equilibrium with thrust and all aerodynamic moments including moments due to loads on components such as tail surfaces and nacelles. Critical thrust values in the range from zero to maximum continuous thrust must be considered.

Disclaimer – This document is not exhaustive and it will be updated gradually.



**3) (NPA 25C-282) Amend paragraph JAR 25.331 title and (a) as follows and delete JAR 25.331(d)**

25.331 Symmetric manoeuvring conditions

(a)*Procedure.* For the analysis of the manoeuvring flight conditions specified in sub-paragraphs (b) and (c) of this paragraph, the following provisions apply:

- (1) Where sudden displacement of a control is specified, the assumed rate of control surface displacement may not be less than the rate that could be applied by the pilot through the control system.
- (2) In determining elevator angles and chordwise load distribution in the manoeuvring conditions of sub-paragraphs (b) and (c) of this paragraph, the effect of corresponding pitching velocities must be taken into account. The in-trim and out-of-trim flight conditions specified in JAR 25.255 must be considered.

**4) (NPA 25C-260) Amend JAR 25.331 by revising paragraph (c) as follows:**

**§ 25.331 General.**

(c)*Pitch manoeuvre conditions.* The conditions in sub-paragraphs (1) and (2) of this paragraph must be investigated. The movement of the pitch control surfaces may be adjusted to take into account limitations imposed by the maximum pilot effort specified by paragraph 25.397(b), control system stops and any indirect effect imposed by limitations in the output side of the control system (for example stalling torque or maximum rate obtainable by a power control system).

- (1) *Maximum pitch control displacement at  $V_A$ .* The aeroplane is assumed to be flying in steady level flight (point  $A_1$ , § 25.333(b)) and the cockpit pitch control is suddenly moved to obtain extreme nose up pitching acceleration. In defining the tail load, the response of the aeroplane must be taken into account. Aeroplane loads which occur subsequent to the time when normal acceleration at the e.g. exceeds the positive limit manoeuvring load factor (at point  $A_2$  in § 25.333(b)), or the resulting tail plane normal load reaches its maximum, whichever occurs first, need not be considered.

**5) (NPA 25C-282) Amend paragraph JAR 25.333 as follows:**

§25.333 Flight manoeuvring envelope

(a)*General.* The strength requirements must be met at each combination of airspeed and load factor on and within the boundaries of the representative manoeuvring envelope ( $V-n$  diagram) of sub-paragraph (b) of this paragraph. This envelope must also be used in determining the aeroplane structural operating limitations as specified in JAR 25.1501.

Disclaimer – This document is not exhaustive and it will be updated gradually.



**6) (NPA 25C-260) Amend JAR 25.335 by revising paragraphs (a)(2) and (b)(2) to read as follows:**

§ 25.335 Design airspeeds

(a) \* \* \*

(2) Except as provided in sub-paragraph 25.335(d)(2),  $V_C$  may not be less than  $V_B + 1.32 U_{ref}$  (with  $U_{ref}$  as specified in subparagraph 25.341(a)(5)(i)). However,  $V_C$  need not exceed the maximum speed in level flight at maximum continuous power for the corresponding altitude.

(3) \* \* \*

(b) \* \* \*

(2) The minimum speed margin must be enough to provide for atmospheric variations (such as horizontal gusts, and penetration of jet streams and cold fronts) and for instrument errors and airframe production variations. These factors may be considered on a probability basis. The margin at altitude where  $M_C$  is limited by compressibility effects must not be less than 0.07M unless a lower margin is determined using a rational analysis that includes the effects of any automatic systems. In any case, the margin may not be reduced to less than 0.05M.

**7) (NPA 25C-282) Amend paragraph JAR 25.335(d) to read as follows, delete ACJ 25.335 (d) Design Speed for maximum gust intensity**

(d) Design speed for maximum gust intensity,  $V_B$

(1)  $V_B$  may not be less than

$$V_{S1} * (1 + \frac{K_g * U_{ref} * V_C * a}{498w})^{1/2}$$

Where:

- $V_{S1}$  = the 1-g stalling speed based on  $C_{NAmax}$  with the flaps retracted at the particular weight under consideration;
- $C_{NAmax}$  = the maximum aeroplane normal force coefficient
- $V_C$  = design cruise speed (knots equivalent airspeed);
- $U_{ref}$  = the reference gust velocity (feet per second equivalent airspeed) from §25.341(a)(5)(i) of this Special Condition
- $W$  = average wing loading (pounds per square foot) at the particular weight under consideration
- $K_g = \frac{0.88\mu}{5.3 + \mu}$
- $m = \frac{2 * w}{\rho c a g}$

Disclaimer – This document is not exhaustive and it will be updated gradually.





- $\rho$  = density of air (slugs ft<sup>3</sup>)
  - $c$  = mean geometric chord of the wing (feet);
  - $g$  = acceleration due to gravity (ft/sec<sup>2</sup>)
  - $a$  = slope of the aeroplane normal force curve,  $C_{NA}$  per radian;
- (2) At altitudes where  $V_C$  is limited by Mach number
- (i)  $V_B$  may be chosen to provide an optimum margin between low and high speed buffet boundaries: and
  - (ii)  $V_B$  need not be greater than  $V_C$

**8) (NPA 25C-282) Amend paragraph JAR 25.341 title and text to read as follows:**

25.341 Gust and turbulence loads

(a) *Discrete Gust Design Criteria.* The aeroplane is assumed to be subjected to symmetrical vertical and lateral gusts in level flight. Limit gust loads must be determined in accordance with the following provisions:

(1) Loads on each part of the structure must be determined by dynamic analysis. The analysis must take into account unsteady aerodynamic characteristics and all significant structural degrees of freedom including rigid body motions.

(2) The shape of the gust must be taken as follows :

$$U = \frac{U_{ds} (1 - \cos(\pi s/H))}{2} \text{ for } 0 \leq s \leq 2H$$

$$U = 0 \quad \text{for } s > 2H$$

Where

$s$  = distance penetrated into the gust (feet);

$U_{ds}$  = the design gust velocity in equivalent airspeed specified in sub-paragraph (a)(4) of this paragraph;

$H$  = the gust gradient which is the distance (feet) parallel to the aeroplane's flight path for the gust to reach its peak velocity

(3) A sufficient number of gust gradient distances in the range 30 feet to 350 feet must be investigated to find the critical response for each load quantity.

(4) The design gust velocity must be:

$$U_{ds} = U_{ref} F_g (H/350)^{1/6}$$

Where

$U_{ref}$  = the reference gust velocity in equivalent airspeed defined in sub-paragraph (a)(5) of this paragraph;

$F_g$  = the flight profile alleviation factor defined in sub-paragraph (a)(6) of this paragraph.

Disclaimer – This document is not exhaustive and it will be updated gradually.



(5) The following reference gust velocities apply :

(i) At airplane speeds between  $V_B$  and  $V_C$ : Positive and negative gusts with reference gust velocities of 56.0 ft/sec EAS must be considered at sea level. The reference gust velocity may be reduced linearly from 56.0 ft/sec EAS at sea level to 44.0 ft/sec EAS at 15 000 feet. The reference gust velocity may be further reduced linearly from 44.0 ft/sec EAS at 15 000 feet to 20.86 ft/sec EAS at 60 000 feet.

(ii) At the aeroplane design speed  $V_D$ :

The reference gust velocity must be 0.5 times the value obtained under §25.341(a)(5)(i).

(6) The flight profile alleviation factor,  $F_g$ , must be increased linearly from the sea level value to a value of 1.0 at the maximum operating altitude defined in JAR 25.1527. At sea level, the flight profile alleviation factor is determined by the following equation:

$$F_g = 0.5 (F_{gz} + F_{gm})$$

Where

$$F_{gz} = 1 - \frac{Z_{mo}}{250\,000}$$

$$F_{gm} = [(R_2 \tan(\pi * R_1 / 4))]^{1/2}$$

$$R_1 = \frac{\text{Maximum landing weight}}{\text{Maximum take-off weight}}$$

$$R_2 = \frac{\text{Maximum zero fuel weight}}{\text{Maximum take-off weight}}$$

$Z_{mo}$  = Maximum operating altitude defined in JAR 25.1527.

7) When a stability augmentation system is included in the analysis, the effect of any significant system non-linearities should be accounted for when deriving limit loads from limit gust conditions.

(b)See SC A1023

(c)Reserved.

**9) (NPA 25C-282) Amend JAR 25.343(b)(1)(ii) to read as follows**

(ii) The gust conditions of paragraph 25.341(a), as modified by this special condition, but assuming 85% of the design velocities prescribed in paragraph 25.341(a)(4)

**10) (NPA 25C-282) Amend JAR 25.345(a) to read as follows:**

(b) If wing-flaps are to be used during take-off, approach, or landing, at the design flap speeds established for these stages of flight under §25.335(e) and with the wing-flaps in the corresponding

Disclaimer – This document is not exhaustive and it will be updated gradually.



positions, the aeroplane is assumed to be subjected to symmetrical manoeuvres and gusts. The resulting limit load must correspond to the conditions determined as follows:

- (1) Manoeuvring to a positive limit load factor of 2.0; and
- (2) Positive and negative gusts of 25 ft/sec EAS acting normal to the flight path in level flight. Gust loads resulting on each part of the structure must be determined by rational analysis. The analysis must take into account the unsteady aerodynamic characteristics and rigid body motions of the aircraft (See ACJ 25.345(a)).

The shape of the gust must be as described in §25.341(a)(2) except that

$U_{ds} = 25 \text{ ft/sec EAS}$

$H = 12.5 c$ ; and

$c = \text{mean geometric chord of the wing (feet)}$

#### **11) (NPA 25C-282) Amend JAR 25.345 (c) To read as follows**

(c) If flaps or other high lift devices are to be used in en-route conditions, and with flaps in the appropriate position at speeds up to the flap design speed chosen for these conditions, the aeroplane is assumed to be subjected to symmetrical manoeuvres and gusts within the range determined by:

- (1) Manoeuvring to a positive limit load factor as prescribed in §25.337(b) and
- (2) The discrete vertical gust criteria in paragraph 25.341(a) (see ACJ 25.345(c)).

#### **12) (NPA 25C-260) Amend JAR 25.345 by revising paragraph (d) to read as follows:**

§ 25.345 High lift devices.

(d) The aeroplane must be designed for a manoeuvring load factor of 1.5g at the maximum take-off weight with the wing-flaps and similar high lift devices in the landing configurations.

#### **13) (NPA 25C-282) Amend JAR 25.349 to read as follows, Delete ACJ 25.349(b) Unsymmetrical gusts:**

§ 25.349 Rolling conditions

The aeroplane must be designed for loads resulting from the rolling conditions specified in subparagraphs (a) and (b) of this paragraph. Unbalanced aerodynamic moments about the centre of gravity must be reacted in a rational or conservative manner, considering the principal masses furnishing the reacting inertia forces.

(a)\*\*\*\*\*

*(b) Unsymmetrical gusts*

Disclaimer – This document is not exhaustive and it will be updated gradually.



The aeroplane is assumed to be subjected to unsymmetrical vertical gusts in level flight. The resulting limit loads must be determined from either the wing maximum airload derived directly from §25.341 (a) or the wing maximum airload derived indirectly from the vertical load factor calculated from §25.341(a).

It must be assumed that 100 percent of the wing airload acts on one side of the aeroplane and 80 percent of the wing airload acts on the other side.

**14) (NPA 25C-260) Amend JAR 25.351 to read as follows:**

**25.351 Yawing manoeuvring conditions**

The aeroplane must be designed for loads resulting from the yaw manoeuvre conditions specified in sub-paragraphs (a) through (d) of this paragraph at speeds from  $V_{MC}$  to  $V_D$ .

Unbalanced aerodynamic moments about the centre of gravity must be reacted in a rational or conservative manner considering the aeroplane inertia forces. In computing the tail loads the yawing velocity may be assumed to be zero.

(a) With the aeroplane in unaccelerated flight at zero yaw, it is assumed that the cockpit rudder control is suddenly displaced to achieve the resulting rudder deflection, as limited by:

- (1) The control system or control surface stops, or
- (2) A limit pilot force of 300 pounds from  $V_{MC}$  to  $V_A$  and 200 pounds from  $V_C/M_C$  to  $V_D/M_D$  with linear variation between  $V_A$  and  $V_C/M_C$ .

(b) With the cockpit rudder control deflected so as always to maintain the maximum rudder deflection available within the limitation specified in sub-paragraph (a) of this paragraph, it is assumed that the aeroplane yaws to the overswing sideslip angle.

(c) With the aeroplane yawed to the static equilibrium sideslip angle, it is assumed that the cockpit rudder control is held so as to achieve the maximum rudder deflection available within the limitations specified in subparagraph (a) of this paragraph.

(d) With the aeroplane yawed to the static equilibrium sideslip angle of paragraph (c) of this paragraph, it is assumed that the cockpit rudder control is suddenly returned to neutral.

**15) (NPA 25C-260) Revise JAR 25.371 to read as follows:**

**§ 25.371 Gyroscopic loads.**

The structure supporting any engine or auxiliary power unit must be designed for the loads, including the gyroscopic loads, arising from the conditions specified in §25.331, 25.341(a), 25.349, 25.351, 25.473, 25.479, and 25.481, with the engine or auxiliary power unit at the maximum rpm appropriate to the condition. For the purposes of compliance with this paragraph, the pitch manoeuvre in § 25.331(c)(1) must be carried out until the positive limit manoeuvring load factor (point  $A_2$  in §25.333(b)) is reached.

Disclaimer – This document is not exhaustive and it will be updated gradually.



**16) (NPA 25C-282) Amend JAR 25.373(a) to read:**

(a)The aeroplane must be designed for the symmetrical manoeuvres prescribed in paragraphs 25.333 and 25.337 , the yawing manoeuvres prescribed in 25.351, and the vertical and lateral gust conditions prescribed in 25.341(a) at each setting and the maximum speed associated with that setting; and

**17) (NPA 25C-282) Amend JAR 25.391 by revising the introductory paragraph and subparagraph (e) to read as follows:**

The control surfaces must be designed for the limit loads resulting from the flight conditions in §25.331, 25.341(a), 25.349 and 25.351 and the ground gust conditions in §25.415 considering the requirements for:

(e)Auxiliary aerodynamic surfaces, in §25.445

**18) (NPA 25C-260) Amend JAR 25.415 by revising paragraph (a)(2) to read as follows:**

§25.415 Ground gust conditions.

(a)•••

(1) •••

(2) The control system stops nearest the surfaces, the control system locks, and the parts of the systems (if any) between these stops and locks and the control surface horns, must be designed for limit hinge moments H, in foot pounds, obtained from the formula,

$$H = 0.0034 * K * V^2 * c * S,$$

Where:

- V = 65 (wind speed in knots)
- K = limit hinge moment factor for ground gusts derived in paragraph (b) of this paragraph.
- c = mean chord of the control surface aft of the hinge line (ft.);
- S = area of the control surface aft of the hinge line (sq.ft);

**19) (NPA 25C-282) Amend JAR 25.427 to read as follows, Delete ACJ 25.427 (b)(1) Unsymmetrical loads. Delete ACJ 25.427 (b) (2) Unsymmetrical loads**

(a)In designing the aeroplane for lateral gust, yaw manoeuvre and roll manoeuvre conditions, account must be taken of unsymmetrical loads on the empennage arising from effects such as slipstream and aerodynamic interference with the wing, vertical fin and other aerodynamic surfaces.

(b)The horizontal tail must be assumed to be subjected to unsymmetrical loading conditions determined as follows:

(1) 100 percent of the maximum loading from the symmetrical manoeuvre conditions of §25.331 and the vertical gust conditions of 25.341(a) acting separately on the surface on one side of the plane of symmetry: and

Disclaimer – This document is not exhaustive and it will be updated gradually.



(2) 80 percent of these loadings acting on the other side

(c) For empennage arrangements where the horizontal tail surfaces have dihedral angles greater than plus or minus 10 degrees, or are supported by the vertical tail surfaces, the surfaces and the supporting structure must be designed for gust velocities specified in §25.341 (a) acting in any orientation at right angles to the flight path.

**20) (NPA 25C-282) Amend JAR 25.445 to read as follows:**

Auxiliary aerodynamic surfaces

(a) When significant, the aerodynamic influence between auxiliary aerodynamic surfaces, such as outboards fins and winglets and their supporting aerodynamic surfaces must be taken into account for all loading conditions including pitch, roll and yaw manoeuvres, and gust as specified in §25.341(a) acting at any orientation at right angles to the flight path.

**21) (NPA 25C-260) Revise JAR 25.473 to read as follows:**

§ 25.473 landing load conditions and assumptions.

(a) For the landing conditions specified in § 25.479 to §25.485 the aeroplane is assumed to contact the ground:

- (1) In the attitudes defined in §25.479 and §25.481.
- (2) With a limit descent velocity of 10 fps at the design landing weight (the maximum weight for landing conditions at maximum descent velocity); and
- (3) With a limit descent velocity of 6 fps at the design takes-off weight (the maximum weight for landing conditions at a reduced descent velocity).
- (4) The prescribed descent velocities may be modified if it is shown that the aeroplane has design features that make it impossible to develop these velocities.

(b) Aeroplane lift, not exceeding aeroplane weight, may be assumed, unless the presence of systems or procedures significantly affects the lift.

(c) The method of analysis of aeroplane and landing gear loads must take into account at least the following elements:

- (1) Landing gear dynamic characteristics.
- (2) Spin-up and spring back.
- (3) Rigid body response.
- (4) Structural dynamic response of the airframe, if significant.

(d) The landing gear dynamic characteristics must be validated by tests as defined in JAR 25.723

(a) (this subparagraph is as modified by SC A1020)

(e) The coefficient of friction between the tyres and the ground may be established by considering the effects of skidding velocity and tyre pressure. However, this coefficient of friction need not be more than 0.8.

Disclaimer – This document is not exhaustive and it will be updated gradually.



**22) (NPA 25C-260) Revise JAR 25.479 to read as follows:**

§ 25.479 Level landing conditions.

(a) In the level attitude, the aeroplane is assumed to contact the ground at forward velocity components, ranging from  $V_{L1}$  to  $1.25 V_{L2}$  parallel to the ground under the conditions prescribed in § 25.473 with:

- (1)  $V_{L1}$  equal to  $V_{S0}$  (TAS) at the appropriate landing weight and in standard sea level conditions: and
- (2)  $V_{L2}$  equal to  $V_{S0}$  (TAS) at the appropriate landing weight and altitudes in a hot day temperature of 41 degrees F above standard.
- (3) The effects of increased contact speed must be investigated if approval of downwind landings exceeding 10 knots is requested.

(b) For the level landing attitude for aeroplanes with tail wheels, the conditions specified in this paragraph must be investigated with the aeroplane horizontal reference line horizontal in accordance with Figure 2 of appendix A of JAR-25.

(c) For the level landing attitude for aeroplanes with nose wheels, shown in Figure 2 of Appendix A of JAR-25, the conditions specified in this paragraph must be investigated assuming the following attitudes:

- (1) An attitude in which the main wheels are assumed to contact the ground with the nose wheel just clear of the ground: and
- (2) If reasonably attainable at the specified descent and forward velocities an attitude in which the nose and main wheels are assumed to contact the ground simultaneously.

(d) In addition to the loading conditions prescribed in paragraph (a) of this paragraph, but with maximum vertical ground reactions calculated from paragraph (a), the following apply:

- (1) The landing gear and directly affected attaching structure must be designed for the maximum vertical ground reaction combined with an aft acting drag component of not less than 25% of this maximum vertical ground reaction.
- (2) The most severe combination of loads that are likely to arise during a lateral drift landing must be taken into account. In absence of a more rational analysis of this condition, the following must be investigated:
  - (i) A vertical load equal to 75% of the maximum ground reaction of §25.473(a)(2) must be considered in combination with a drag and side load of 40% and 25%, respectively, of that vertical load.
  - (ii) The shock absorber and tyre deflections must be assumed to be 75% of the deflection corresponding to the maximum ground reaction of §25.473(a)(2). This load case need not be considered in combination with flat tyres.
- (3) The combination of vertical and drag components is considered to be acting at the wheel axle centreline.

**23) (NPA 25C-260) Amend JAR 25.481 by revising paragraph (a) to read as follows:**

Disclaimer – This document is not exhaustive and it will be updated gradually.





§ 25.481 Tail down landing conditions.

(a) In the tail-down attitude, the aeroplane is assumed to contact the ground at forward velocity components, ranging from VL1 to VL2 parallel to the ground under the conditions prescribed in §25.473 with:

- (1) \*\*\*
- (2) \*\*\*

**24) (NPA 25C-260) Amend JAR 25.483 by revising the title, the introductory text, and paragraph (a) to read as follows:**

§ 25.483 One-gear landing conditions.

For the one-gear landing conditions, the aeroplane is assumed to be in the level attitude and to contact the ground on one main landing gear, in accordance with Figure 4 of Appendix A of JAR-25.

In this attitude:

- (a) The ground reactions must be the same as those obtained on that side under §25.479(d)(1), and
- (b) \*\*\*

**25) (NPA 25C-260) Revise JAR 25.485 to read as follows:**

§ 25.485 Side Load conditions.

In addition to §25.479(d)(2) the following conditions must be considered:

- (a) \* \* \*
- (b) \* \* \*

**26) (NPA 25C-260) Revise JAR 25.491 and its title as follows, Delete ACJ 25.491- Take-Off run**

§ 25.491 Taxi, take-off and landing roll.

Within the range of appropriate ground speeds and approved weights, the aeroplane structure and landing gear are assumed to be subjected to loads not less than those obtained when the aircraft is operating over the roughest ground that may reasonably be expected in normal operation.

**27) (NPA 25C-260) Amend JAR 25.499 by revising paragraph (e) as follows:**

§ 25.499 Nose-wheel yaw and steering.

(e) With the aeroplane at design ramp weight, and the nose gear in any steerable position, the combined application of full normal steering torque and vertical force equal to 1.33 times the maximum static reaction on the nose gear must be considered in designing the nose gear, its attaching structure, and the forward fuselage structure.

**28) (NPA 25C-260) Amend JAR 25.511(b) by deleting the following text:**

Disclaimer – This document is not exhaustive and it will be updated gradually.



“The resulting side to side distribution on the unit must not be assumed less than the ratio 55:45. For twin wheel units a loading distribution in the ratio 55:45 may be considered in lieu of the rational analysis of this sub-paragraph (b).”

**29) (NPA 25C-260) Amend JAR 25.561 by revising paragraph (c) as follows:**

§ 25.561 General

(c) For equipment, cargo in the passenger compartments and any other large masses, the following apply:

- (3) These items must be positioned so that if they break loose they will be unlikely to:
  - (i) Cause direct injury to occupants;
  - (ii) Penetrate fuel tanks or lines or cause fire or explosion hazard by damage to adjacent systems; or
  - (iii) Nullify any of the escape facilities provided for use after an emergency landing.

(4) When such positioning is not practical (e.g. fuselage mounted engines or auxiliary power units) each such item of mass shall be restrained under all loads up to those specified in paragraph (b)(3) of this paragraph. The local attachments for these items should be designed to withstand 1.33 times the specified loads if these items are subject to severe wear and tear through frequent removal (e.g. quick change interior items).

**30) (NPA 25C-282) Amend JAR 25.571 (b) (2) and (b) (3) to read as follows:**

(b)

- (2) The limit gust conditions specified in JAR 25.341 at the specified speeds up to  $V_C$  and in JAR 25.345.
- (3) The limit rolling conditions specified in JAR 25.349 and the limit unsymmetrical conditions specified in JAR 25.367 and JAR 25.427 (a) through (c), at speeds up to  $V_C$ .

**31) (NPA 25C-282) Amend Paragraph 25XI517 Rough Air Speed  $V_{RA}$**

Not taken into account- Refer to SC A 1023 [continuous turbulence] which is superseding NPA 25C-282 for this paragraph.

**Acronyms and Abbreviations**

<b>ACJ</b>	Advisor Circular Joint
<b>EAS</b>	Equivalent Air Speed
<b>NPA</b>	Notice of Proposed Amendment
<b>SC</b>	Special Condition
<b>TAS</b>	True Air Speed
<b>JAR</b>	Joint Aviation Regulation
<b>FAR</b>	Federal Aviation Regulations
<b>NPA</b>	Notice of Proposed Amendment

Disclaimer – This document is not exhaustive and it will be updated gradually.



---

## A-1002: INTERACTION OF SYSTEMS AND STRUCTURE

<b>SPECIAL CONDITION</b>	<b>A-1002: Interaction of Systems and Structure</b>
APPLICABILITY:	A340-500/-600
REQUIREMENTS:	JAR 25 Subpart C and D
ISSUE:	3 dated 29/03/2001

### Special Condition summary

## BACKGROUND

The A340-500/-600 is equipped with systems which directly or as a result of failure or malfunction affect its structural performance. Certification loads for the aircraft must consider these effects of systems on structural performance. This must include normal operation and failure conditions with strength levels related to probability of occurrence.

There is a need to develop a special condition to account for these new features.

## SPECIAL CONDITION

### 1. Add a new paragraph § 25.302 to read as follows:

#### § 25.302 Interaction of systems and structures.

For aeroplanes equipped with systems that affect structural performance, either directly or as a result of a failure or malfunction, the influence of these systems and their failure conditions must be taken into account when showing compliance with the requirements of Subparts C and D.

Appendix L must be used to evaluate the structural performance of aeroplanes equipped with these systems.

### 2. JAR 25.305 is revised by adding sub-paragraphs (f) as follows:

(f) Unless shown to be extremely improbable, the aeroplane must be designed to withstand any forced structural vibration resulting from any failure, malfunction or adverse condition in the flight control system. These loads must be treated in accordance with the requirements of §25.302.

### 3. Add a new appendix L to read as follows:

#### Appendix L to JAR-25- Interaction of Systems and Structure

##### L 25.1. General.

The following criteria must be used for showing compliance with §25.302 and §25.629 for aeroplanes equipped with flight control systems, autopilots, stability augmentation systems, load

Disclaimer – This document is not exhaustive and it will be updated gradually.



alleviation systems, flutter control systems, and fuel management systems. If this appendix is used for other systems, it may be necessary to adapt the criteria to the specific system.

a) The criteria defined herein only address the direct structural consequences of the system responses and performances and cannot be considered in isolation but should be included in the overall safety evaluation of the aeroplane. These criteria may in some instances duplicate standards already established for this evaluation. These criteria are only applicable to structure whose failure could prevent continued safe flight and landing. Specific criteria that define acceptable limits on handling characteristics or stability requirements when operating in the system degraded or inoperative mode are not provided in this appendix.

b) Depending upon the specific characteristics of the aeroplane, additional studies may be required that go beyond the criteria provided in this appendix in order to demonstrate the capability of the aeroplane to meet other realistic conditions such as alternative gust or manoeuvre descriptions for an aeroplane equipped with a load alleviation system.

c) The following definitions are applicable to this appendix.

**Structural performance:** Capability of the aeroplane to meet the structural requirements of JAR 25.

**Flight limitations:** Limitations that can be applied to the aeroplane flight conditions following an in-flight occurrence and that are included in the flight manual (e.g. speed limitations, avoidance of severe weather conditions, etc.).

**Operational limitations:** Limitations, including flight limitations that can be applied to the aeroplane operating conditions before dispatch (e.g., fuel, payload and Master Minimum Equipment List limitations).

**Probabilistic terms:** The probabilistic terms (probable, improbable, extremely improbable) used in this appendix are the same as those used in § 25.1309.

**Failure condition:** The term failure condition is the same as that used in §25.1309, however this appendix applies only to system failure conditions that affect the structural performance of the aeroplane (e.g., system failure conditions that induce loads, change the response of the aeroplane to inputs such as gusts or pilot actions, or lower flutter margins).

## L25.2. Effects of Systems on Structures.

a) General. The following criteria will be used in determining the influence of a system and its failure conditions on the aeroplane structure.

b) System fully operative. With the system fully operative, the following apply:

(1) Limit loads must be derived in all normal operating configurations of the system from all the limit conditions specified in Subpart C, taking into account any special behaviour of

Disclaimer – This document is not exhaustive and it will be updated gradually.



such a system or associated functions or any effect on the structural performance of the aeroplane that may occur up to the limit loads. In particular, any significant nonlinearity (rate of displacement of control surface, thresholds or any other system nonlinearities) must be accounted for in a realistic or conservative way when deriving limit loads from limit conditions.

(2) The aeroplane must meet the strength requirements of JAR 25 (Static strength, residual strength), using the specified factors to derive ultimate loads from the limit loads defined above. The effect of non linearities must be investigated beyond limit conditions to ensure the behaviour of the system presents no anomaly compared to the behaviour below limit conditions. However, conditions beyond limit conditions need not be considered when it can be shown that the aeroplane has design features that will not allow it to exceed those limit conditions.

(3) The aeroplane must meet the aeroelastic stability requirements of § 25.629.

c) System in the failure condition. For any system failure condition not shown to be extremely improbable, the following apply:

(1) At the time of occurrence. Starting from 1-g level flight conditions, a realistic scenario, including pilot corrective actions, must be established to determine the loads occurring at the time of failure and immediately after failure.

(i) For static strength substantiation, these loads multiplied by an appropriate factor of safety that is related to the probability of occurrence of the failure are ultimate loads to be considered for design. The factor of safety (F.S.) is defined in Figure 1.

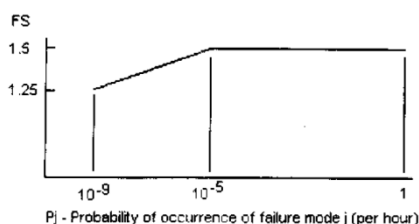

Figure 1 – factor of safety at the time of occurrence

(ii) For residual strength substantiation, the aeroplane must be able to withstand two thirds of the ultimate loads defined in subparagraph (c)(1)(i).

(iii) Freedom from aeroelastic instability must be shown up to the speeds defined in §25.629(b)(2). For failure conditions that result in speed increases beyond  $V_C/M_C$ , freedom from aeroelastic instability must be shown to increased speeds, so that the margins intended by §25.629 (b)(2) are maintained.

(iv) Failures of the system that result in forced structural vibrations (oscillatory failures) must not produce loads that could result in detrimental deformation of primary structure.

(2) For the continuation of the flight. For the aeroplane, in the system failed state and considering any appropriate reconfiguration and flight limitations, the following apply:

(i) The loads derived from the following conditions at speeds up to  $V_C$ , or the speed limitation prescribed for the remainder of the flight must be determined:

(A) The limit symmetrical manoeuvring conditions specified in §25.331 and in §25.345.

(B) The limit gust and turbulence conditions specified in §25.341 and in §25.345.

Disclaimer – This document is not exhaustive and it will be updated gradually.



- (C) The limit rolling conditions specified in §25.349 and the limit unsymmetrical conditions specified in §25.367 and §25.427(b) and (c).
- (D) The limit yaw manoeuvring conditions specified in §25.351.
- (E) The limit ground loading conditions specified in §25.473 and §25.491.
- (ii) For static strength substantiation, each part of the structure must be able to withstand the loads in subparagraph (2)(i) of this paragraph multiplied by an actor of safety depending on the probability of being in this failure state. The factor of safety is defined in Figure 2.

Figure 2  
Factor or safety for continuation of flight

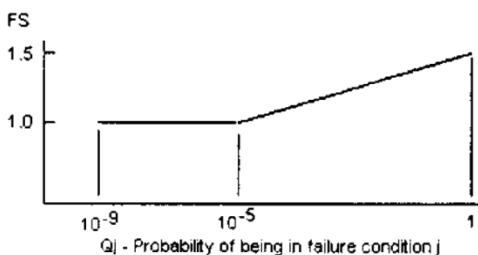

$Q_j = (T_j)(P_j)$  where:  
 $T_j$  = Average time spent in failure condition j (in hours)  
 $P_j$  = Probability of occurrence of failure mode j (per hour)  
**Note:** If  $P_j$  is greater than  $10^{-3}$ , per flight hour then a 1.5 factor of safety must be applied to all limit load conditions specified in Subpart C.

- (iii) For residual strength substantiation, the aeroplane must be able to withstand two thirds of the ultimate loads defined in subparagraph (c) (2) (ii).
- (iv) If the loads induced by the failure condition have a significant effect on fatigue or damage tolerance then their effects must be taken into account.
- (v) Freedom from aeroelastic instability must be shown up to a speed determined from Figure 3. Flutter clearance speeds  $V'$  and  $V''$  may be based on the speed limitation specified for the remainder of the flight using the margins defined by §25.629(b).

Figure 3  
Clearance speed

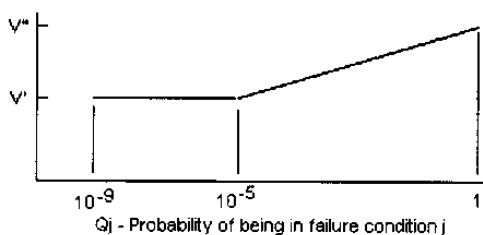

$V'$  = Clearance speed as defined by § 25.629(b)(2).  
 $V''$  = Clearance speed as defined by § 25.629(b)(1).  
 $Q_j = (T_j)(P_j)$  where:  
 $T_j$  = Average time spent in failure condition j (in hours)  
 $P_j$  = Probability of occurrence of failure mode j (per hour)  
**Note:** If  $P_j$  is greater than  $10^{-3}$  per flight hour, then the flutter clearance speed must not be less than  $V''$ .

Disclaimer – This document is not exhaustive and it will be updated gradually.



(vi) Freedom from aeroelastic instability must also be shown up to V' in Figure 3 above, for any probable system failure condition combined with any damage required or selected for investigation by §25.571(b).

(3) Consideration of certain failure conditions may be required by other Sections of this Part regardless of calculated system reliability. Where analysis shows the probability of these failure conditions to be less than  $10^{-9}$ , criteria other than those specified in this paragraph may be used for structural substantiation to show continued safe flight and landing.

d) Warning considerations. For system failure detection and warning, the following apply:

(1) The system must be checked for failure conditions, not extremely improbable, that degrade the structural capability below the level required by part 25 or significantly reduce the reliability of the remaining system. The flight crew must be made aware of these failures before flight. Certain elements of the control system, such as mechanical and hydraulic components, may use special periodic inspections, and electronic components may use daily checks, in lieu of warning systems to achieve the objective of this requirement. These certification maintenance requirements must be limited to components that are not readily detectable by normal warning systems and where service history shows that inspections will provide an adequate level of safety.

(2) The existence of any failure condition, not extremely improbable, during flight that could significantly affect the structural capability of the aeroplane and for which the associated reduction in airworthiness can be minimized by suitable flight limitations, must be signalled to the flight crew. For example, failure conditions that result in a factor of safety between the aeroplane strength and the loads of Subpart C below 1.25, or flutter margins below V", must be signalled to the crew during flight.

e) Dispatch with known failure conditions. If the aeroplane is to be dispatched in a known system failure condition that affects structural performance, or affects the reliability of the remaining system to maintain structural performance, then the provisions of §25.302 must be met for the dispatched condition and for subsequent failures. Flight limitations and expected operational limitations may be taken into account in establishing Qj as the combined probability of being in the dispatched failure condition and the subsequent failure condition for the safety margins in Figures 2 and 3. These limitations must be such that the probability of being in this combined failure state and then subsequently encountering limit load conditions is extremely improbable. No reduction in these safety margins is allowed if the subsequent system failure rate is greater than  $1E-3$  per flight hour.

## Acronyms and Abbreviations

<b>JAR</b>	Joint Aviation Regulation
<b>F.S.</b>	Factor of Safety

Disclaimer – This document is not exhaustive and it will be updated gradually.





## A-1003: DESIGN MANOEUVRE REQUIREMENTS

<b>SPECIAL CONDITION</b>	<b>A-1003: Design manoeuvre requirements</b>
APPLICABILITY:	A340-500/-600
REQUIREMENTS:	25.301 (b), 25.331(c), 25.349(a), 25.351(e),
ISSUE:	2 dated 18/10/2000

### Special Condition summary

## BACKGROUND

Existing Requirements for design maneuvers need to be modified because they are not adequate for an aircraft with electronic flight controls.

## SPECIAL CONDITION

### 1. Add to JAR 25.331 (c) paragraph (c) (3) to read as follows:

It must be established that manoeuvre loads induced by the system itself (e.g. abrupt changes in orders made possible by electric rather than mechanical combination of different inputs) are acceptably accounted for.

### 2. Replace JAR 25.349 (a) by :

a) Manoeuvring: the following conditions, speeds and cockpit roll control motions (except as the motions may be limited by pilot effort) must be considered in combination with an aeroplane load factor of zero and the two-thirds of limit positive manoeuvring load factor. In determining the resulting control surface deflections the torsional flexibility of the wing must be considered in accordance with JAR 25.301 (b):

- 1) Conditions corresponding to maximum steady rolling velocities and conditions corresponding to maximum angular accelerations must be investigated. For the angular acceleration conditions zero rolling velocity may be assumed in the absence of a rational time history investigation of the manoeuvre.
- 2) At  $V_A$  movement of the cockpit roll control up to the limit is assumed. The position of the cockpit roll control must be maintained until a steady roll rate is achieved and then must be returned suddenly to the neutral position.
- 3) At VC the cockpit roll control must be moved suddenly and maintained so as to achieve a roll rate not less than that obtained in sub-paragraph (2) of this paragraph.
- 4) At VD the cockpit roll control must be moved suddenly and maintained so as to achieve a roll rate not less than one third of that obtained in sub-paragraph (2) of this paragraph.
- 5) It must be established that manoeuvre loads induced by the system itself (i.e. abrupt changes in orders made possible by electrical rather than mechanical combination of different inputs) are acceptably accounted for.

Disclaimer – This document is not exhaustive and it will be updated gradually.





---

**3. Add a new subparagraph (e) to JAR 25.351 (as provided in SC A 1001) as follows:**

JAR 25.351 (e)

It must be established that manoeuvre loads induced by the system itself (i.e. abrupt changes in orders made possible by electrical rather than mechanical combination of different inputs) are acceptably accounted for.

**Acronyms and Abbreviations**

<b>JAR</b>	Joint Aviation Regulation
<b>SC</b>	Special Condition

Disclaimer – This document is not exhaustive and it will be updated gradually.



## A-1004: DESIGN DIVE SPEED VD

SPECIAL CONDITION	A-1004: Design Dive Speed Vd
APPLICABILITY:	A340-500/-600
REQUIREMENTS:	25.335 (b)(1) and (b)(2),
ISSUE:	2 dated 19/01/2001

### Special Condition summary

#### BACKGROUND

The A340-500/-600 is equipped, with a high speed protection system which limits nose down pilot authority at speeds above  $V_C/M_C$ . The requirement of JAR 25.335(b)(1) must therefore be adapted.

For basic A340 aircraft models, Special Condition A4 was issued considering that the delay mentioned in 25.335 (b)(1)(ii) had been increased to 3 seconds.

JAR 25.335(b)(1) as provided by SC A4 should be applicable to A340-500/-600 without change.

JAR 25.335(b)(2) as provided by SC A4 is now included in JAR 25 change 14 plus OP 96/1.

#### SPECIAL CONDITION

Modify JAR 25.335(b) to read:

(b) *Design Dive speed*  $V_D$ .  $V_D$  must be selected so that  $V_C/M_C$  is not greater than  $0.8 V_D/M_D$  or so that the minimum speed margin between  $V_C/M_C$  and  $V_D/M_D$  is the greater of the following values:

- 1) The speed increase above  $V_C/M_C$  resulting from the following manoeuvres:
  - (i) From an initial condition of stabilised flight at  $V_C/M_C$ , the aeroplane is upset so as to take up a new flight path  $7.5^\circ$  below the initial path. Control application, up to full authority is made to try and maintain this new flight path. Twenty seconds after initiating the upset manual recovery is made at a load factor of 1.5 g (0.5 g acceleration increment) or such greater load factor that is automatically applied by the system with the pilot's pitch control neutral. The speed increase occurring in this manoeuvre may be calculated, if reliable or conservative aerodynamic data is used. Power as specified in JAR 25.175(b)(1)(iv) is assumed until recovery is made at which time power reduction and the use of pilot controlled drag devices may be assumed.
  - (ii) From a speed below  $V_C/M_C$  with power to maintain stabilised level flight at this speed the aeroplane is upset so as to accelerate through  $V_C/M_C$  at a flight path  $15^\circ$  below the initial path (or at the steepest nose down attitude that the system will permit with full control authority if less than  $15^\circ$ ).

Disclaimer – This document is not exhaustive and it will be updated gradually.



Note: pilot controls may be in neutral position after reaching  $V_C/M_C$  and before recovery is initiated.

Recovery may be initiated 3 seconds after operation of high speed attitude or other alerting system by application of a load factors of 1.5 g (0.5 g acceleration increment) or such greater load factor that is automatically applied by the system with the pilot's pitch control neutral. Power may be reduced simultaneously.

All other means of decelerating the aeroplane, the use of which is authorised up to the highest speed reached in the manoeuvre may be used. The interval between successive pilot actions must not be less than one second.

2) The minimum speed margin must be enough to provide for atmospheric variations (such as horizontal gusts, and penetration of jet streams and cold fronts) and for instruments errors and airframe production variations. These factors may be considered on a probability basis. However, the margin at altitude where MC is limited by compressibility effects may not be less than 0.05 M.

### Acronyms and Abbreviations

<b>JAR</b>	Joint Aviation Regulation
<b>OP</b>	Orange Paper
<b>SC</b>	Special Condition

Disclaimer – This document is not exhaustive and it will be updated gradually.



## A-1006: GROUND LOADS AND CONDITIONS FOR CENTRAL LANDING GEAR

<b>SPECIAL CONDITION</b>	<b>A-1006: Ground Loads and Conditions for Central Landing Gear</b>
APPLICABILITY:	A340-500/A340-600
REQUIREMENTS:	JAR 25.473, 25.477, 25.479, 25.481, 25.483, 25.485, 25.489, 25.493, 25.495, 25.503, 25.723
ISSUE:	3 dated 10/04/2001

### Special Condition summary

#### BACKGROUND

The A340-500/-600 landing gear arrangement includes a braked four-wheel central landing gear under the fuselage that acts in all respects with the full capability of a main landing gear. JAR 25 requirements does not adequately address aircraft with Centre Landing Gear. This unconventional arrangement requires a special condition.

#### SPECIAL CONDITION

**1) In addition to the requirements of § 25.473 “Ground load conditions and assumptions”, the following apply:**

Landing should be considered on a level runway and on a runway having a convex upward shape that may be approximated by a slope of 1.5 percent with the horizontal at main landing gears stations. The maximum loads determined from these two conditions must be applied to each main landing gear and to the central landing gear.

**2) The requirements of § 25.483 «One-wheel landing conditions» apply and, in addition, the condition represented by the following figure also applies:**

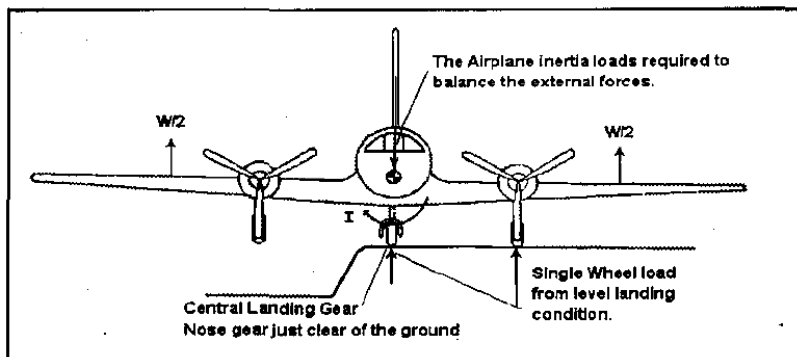

Figure 1: Center gear landing Condition

**3) In lieu of the requirements of § 25.485 "Side load conditions", the following apply:**

(a) The airplane is considered to be in the level attitude with only the main and central wheels contacting the ground.

Disclaimer – This document is not exhaustive and it will be updated gradually.

(b) Vertical reactions of one-half of the maximum vertical reaction obtained at each main and central gear in the level landing conditions should be considered. The vertical loads must be combined with side loads that for the main gear are 0.8 of the vertical reaction (on one side) acting inward and 0.6 of the vertical reaction (on the other side) acting outward, and for the central gear are 0.7 of the vertical reaction acting in the same direction as main gear side loads. These loads are assumed to be applied at the ground contact point and to be resisted by the inertia of the aeroplane. The drag loads may be assumed to be zero.

**4) In addition to § 25.489 "Ground handling conditions", the following applies:**

The airplane should be considered to be on a level runway and on a runway having a convex upward shape that may be approximated by a slope of 1.5 percent with the horizontal at main landing gear stations. The ground reactions must be distributed to the individual landing gear units in a rational or conservative manner.

**5) In addition to the requirements of § 25.493(d) "Braked roll conditions" the following applies:**

The sudden application of maximum braking effort must be defined taking into account the behaviour of the braking system. Failure conditions of the braking system must be analysed in accordance with SC A-1002. "Interaction of Systems and Structures". Paragraph 25.493(e) from NPA 25C-276 / SC A-1017 does not apply due to the unconventional gear arrangement.

**6) In lieu of the requirements of § 25.495 "Turning", the following apply:**

- a) The airplane is assumed to execute a steady turn by nose gear steering, or by application of sufficient differential power, so that the limit load factors applied at the centre of gravity are 1.0 vertically and 0.5 laterally.
- (b) The airplane must be designed for the condition prescribed in sub-paragraph (a) of this paragraph, taking into account:
  - The effects of tire characteristics on the sharing of lateral loads on each tire of the landing gear system, and
  - The effect of airframe and landing gear flexibility on the sharing of loads on the different legs of landing gear system.

**7) In lieu of the requirements of § 25.503 "Pivoting", the following apply:**

- a) The main and central gear units and supporting structure must be designed for the scrubbing or torsion loads, or both, induced by pivoting during ground manoeuvres produced by:
  - i) Towing at the nose gear, no brakes applied, and
  - ii) Application of symmetrical or unsymmetrical forward thrust to aid pivoting and with or without braking by pilot action on the pedals.
- b) The airplane is assumed to be in static equilibrium, with the loads being applied at the ground contact points.

Disclaimer – This document is not exhaustive and it will be updated gradually.



- c) The limit vertical load factor must be 1.0 and:
  - i) For wheels with locked brakes, the coefficient of friction must be 0.8.
  - ii) For wheels with brakes not applied, the ground tire reactions must be based on reliable tire data.
- d) The failure conditions must be analysed in accordance with SC A-1002 "Interaction of System and structures"

**8) The following applies to the central gear in lieu of §25.723(b) "Shock absorption tests":**

The central landing gear should not fail in a test demonstrating its reserve energy absorption capacity at design landing weight assuming airplane lift no greater than the airplane weight acting during a 12 fps airplane landing impact taking into account both main and central gear acting during the impact.

Landing should be considered on a level runway or a runway having a convex upward shape that may be approximated by a slope of 1.5 percent with the horizontal at main landing gear stations, whichever is the most critical.

**Acronyms and Abbreviations**

<b>JAR</b>	Joint Aviation Regulation
<b>SC</b>	Special Condition
<b>NPA</b>	Notice of Proposed Amendment

Disclaimer – This document is not exhaustive and it will be updated gradually.



## A-1011: VIBRATION, BUFFET AND AEROELASTIC STABILITY REQUIREMENTS

<b>SPECIAL CONDITION</b>	<b>A-1011: Vibration, Buffet and Aeroelastic Stability Requirements</b>
APPLICABILITY:	A340-500/-600
REQUIREMENTS:	JAR 25.251, 25.305, 25.629
ISSUE:	2 dated 28/09/2000

### Special Condition summary

#### BACKGROUND

The applicable Joint Certification Basis for A340-500/-600 is JAR 25 change 14 plus JAR Amendment 25/96/1.

The use of NPA 25BCD-236- Vibration, buffet and aeroelastic stability requirements, would align the JAR 25 certification basis with the intent of FAR amendment 25-77 for flutter requirements.

#### SPECIAL CONDITION

##### 1. JAR 25.251 (a) and (b) are revised to read as follows:

JAR 25.251 Vibrating and buffeting.

(a) The aeroplane must be demonstrated in flight to be free from any vibration and buffering that would prevent continued safe flight in any likely operating condition.

(b) Each part of the aeroplane must be demonstrated in flight to be free from excessive vibration under any appropriate speed and power conditions up to  $V_{DF}/M_{DF}$ . The maximum speeds shown must be used in establishing the operating limitations of the aeroplane in accordance with JAR 25.1505.

##### 2. JAR 25.305 is revised by adding sub-paragraph (e) as follows:

(e) The aeroplane must be designed to withstand any vibration and buffeting that might occur in any likely operating condition up to  $V_D/M_D$  including stall and probable inadvertent excursions beyond the boundaries of the buffet onset envelope. This must be shown by analysis, flight tests, or other tests found necessary by the Authority.

##### 3. JAR 25.427 is revised by adding a new sub-paragraph (d) as follows:

(d) Unsymmetrical loading on the empennage arising from buffet conditions of JAR 25.305(e) must be taken into account.

##### 4. JAR 25.629 is revised to read as follows:

Disclaimer – This document is not exhaustive and it will be updated gradually.



JAR 25.629 Aeroelastic stability requirements.

(a) *General.* The aeroelastic stability evaluations required under this paragraph include flutter, divergence, control reversal and any undue loss of stability and control as a result of structural deformation. The aeroelastic evaluation must include whirl modes associated with any propeller or rotating device that contributes significant dynamic forces. Compliance with this paragraph must be shown by analyses, tests, or some combination thereof as found necessary by the Authority (see ACJ 25.629).

(b) *Aeroelastic stability envelopes.* The aeroplane must be designed to be free from aeroelastic instability for all configurations and design conditions within the aeroelastic stability envelopes as follows:

- (1) For normal conditions without failures, malfunctions, or adverse conditions, all combinations of altitudes and speeds encompassed by the  $V_D/M_D$  versus altitude envelope enlarged at all points by an increase of 15 percent in equivalent airspeed at constant Mach number and constant altitude. In addition, a proper margin of stability must exist at all speeds up  $V_D/M_D$  and, there must be no large and rapid reduction in stability as  $V_D/M_D$  is approached. The enlarged envelope may be limited to Mach 1.0 when  $M_D$  is less than 1.0 at all design altitudes; and
- (2) For the conditions described in JAR 25.629(d) below, for all approved altitudes, any airspeed up to the greater airspeed defined by:
  - (i) The  $V_D/M_D$  envelope determined by JAR 25.335(b); or,
  - (ii) An altitude-airspeed envelope defined by a 15 percent increase in equivalent airspeed above  $V_C$  at constant altitude, from sea level to the altitude of the intersection of  $1.15 V_C$  with the extension of the constant cruise Mach number line,  $M_C$ , then a linear variation in equivalent airspeed to  $M_C+0.05$  at the altitude of the lowest  $V_C/M_C$  intersection; then, at higher altitudes, up to the maximum flight altitude, the boundary defined by a 0.05 Mach increase in  $M_C$  at constant altitude; and
  - (iii) Failure conditions of certain systems must be treated in accordance with JAR 25.302.

(c) *Balance weights.* If balance weights are used, their effectiveness and strength, including supporting structure, must be substantiated.

(d) *Failures, malfunctions, and adverse conditions.* The failures, malfunctions, and adverse conditions which must be considered in showing compliance with this paragraph are:

- (1) Any critical fuel loading conditions, not shown to be extremely improbable, which may result from mismanagement of fuel.
- (2) Any failure in any flutter control system not shown to be extremely improbable.
- (3) For aeroplanes not approved for operation in icing conditions, the maximum likely ice accumulation expected as a result of an inadvertent encounter.
- (4) Failure of any single element of the structure supporting any engine, independently mounted propeller shaft, large auxiliary power unit, or large externally mounted aerodynamic body (such as an external fuel tank).

Disclaimer – This document is not exhaustive and it will be updated gradually.





(5) For aeroplanes with engines that have propellers or large rotating devices capable of significant dynamic forces, any single failure of the engine structure that would reduce the rigidity of the rotational axis.

(6) The absence of aerodynamic or gyroscopic forces resulting from the most adverse combination of feathered propellers or other rotating devices capable of significant dynamic forces. In addition, the effect of a single feathered propeller or rotating device must be coupled with the failures of sub-paragraphs (d)(4) and (d)(5) of this paragraph.

(7) Any single propeller or rotating device capable of significant dynamic forces rotating at the highest likely overspeed.

(8) Any damage or failure condition, required or selected for investigation by JAR 25.571. The single structural failures described in sub-paragraphs (d)(4) and (d)(5) of this paragraph need not be considered in showing compliance with this paragraph if;

(i) The structural element could not fail due to discrete source damage resulting from the conditions described in JAR 25.571(e) and 25.903(d); and

(ii) A damage tolerance investigation in accordance with JAR 25.571(b) shows that the maximum extent of damage assumed for the purpose of residual strength evaluation does not involve complete failure of the structural element.

(9) Any damage, failure or malfunction, considered under JAR 25.631, 25.671, 25.672, and 25.1309.

(10) Any other combination of failures, malfunctions, or adverse conditions not shown to be extremely improbable.

(e) *Flight flutter testing.* Full scale flight flutter tests at speeds up to  $V_{DF}/M_{DF}$  must be conducted for new type designs and for modifications to a type design unless the modifications have been shown to have an insignificant effect on the aeroelastic stability. These tests must demonstrate that the aeroplane has a proper margin of damping at all speeds up to  $V_{DF}/M_{DF}$  and that there is no large and rapid reduction in damping as  $V_{DF}/M_{DF}$  is approached. If a failure, malfunction, or adverse condition is simulated during flight test in showing compliance with sub-paragraph (d) of this paragraph, the maximum speed investigated need not exceed  $V_{FC}/M_{FC}$  if it is shown, by correlation of the flight test data with other test data or analyses, that the aeroplane is free from any aeroelastic instability at all speeds within the altitude-airspeed envelope described in sub-paragraph (b)(2) of this paragraph.

## Acronyms and Abbreviations

<b>JAR</b>	Joint Aviation Regulation
<b>NPA</b>	Notice of Proposed Amendment
<b>FAR</b>	Federal Aviation Regulations
<b>ACJ</b>	Advisory Circular Joint

Disclaimer – This document is not exhaustive and it will be updated gradually.



## A-1015: CHECKED PITCHING MANOEUVRE LOADS

<b>SPECIAL CONDITION</b>	<b>A-1015: Checked Pitching Manoeuvre loads</b>
APPLICABILITY:	A340-500/-600
REQUIREMENTS:	JAR 25.331(c)(2)
ISSUE:	2 dated 24/01/2001

### Special Condition summary

## BACKGROUND

The checked pitch manoeuvre as harmonised between JAA / FAA is based on the manoeuvre from JAR 25.331(c)(2) and ACJ 25.331(c)(2) at Change 14 plus JAR Amendment 25/96/1, where the baseline sine wave control motion is modified when needed to try to achieve the specified airplane load factors. The harmonised checked pitch manoeuvre with the stretched sine input will create more severe design loads for the tailplane and therefore provide for an increased level of safety.

The harmonised checked pitch manoeuvre is a result of the harmonisation activity under the auspices of the ARAC Loads and Dynamics Harmonisation Working Group, in which members of the JAA Structures Study Group (SSG) participated. A firm technical consensus has been reached on this requirement by the ARAC Loads and Dynamics Harmonisation Working Group.

Therefore, the JAA team agrees to apply the following harmonised checked pitch manoeuvre, as based on P-NPA 25C308 dated 29/02/2000, provided under Special Condition A-1015, as an Equivalent Safety finding to JAR 25.331(c)(2) for inclusion in A340-500/-600 JAA certification basis.

## SPECIAL CONDITION

### 1. Amend JAR 25.331(c)(2) to read as follows:

JAR 25.331 Symmetric manoeuvring conditions.

(c) Manoeuvring pitching conditions. The following conditions must be investigated:

(1) \*\*\*

(2) Checked manoeuvre between  $V_A$  and  $V_D$ . Nose up checked pitching manoeuvres must be analysed in which the positive limit load factor prescribed in JAR 25.337 is achieved. As a separate condition, nose down checked pitching manoeuvres must be analysed in which a limit load factor of 0g is achieved. In defining the aeroplane loads the cockpit pitch control motions described in sub-paragraphs (i), (ii), (iii) and (iv) of this paragraph must be used:

Disclaimer – This document is not exhaustive and it will be updated gradually.



(i) The aeroplane is assumed to be flying in steady level flight at any speed between  $V_A$  and  $V_D$  and the cockpit pitch control is moved in accordance with the following formula:

$$\delta(t) = \delta_1 * \sin(\omega t) \quad \text{for } 0 \leq \omega t \leq t_{\max}$$

Where:

- $\delta_1$  = the maximum available displacement of the cockpit pitch control in the initial direction, as limited by the control system stops, control surface stops, or by pilot effort in accordance with JAR 25.397(b);
- $\delta(t)$  = the displacement of the cockpit pitch control as a function of time. In the initial direction  $\delta(t)$  is limited to  $\delta_1$ . In the reverse direction,  $\delta(t)$  may be truncated at the maximum available displacement of the cockpit pitch control as limited by the control system stops, control surface stops, or by pilot effort in accordance with JAR 25.397(b);
- $t_{\max} = 3\pi/2\omega$
- $\omega$  = the circular frequency (radians/second) of the control deflection taken equal to the undamped natural frequency of the short period rigid mode of the aeroplane, with active control system effects included where appropriate; but not less than:

$$\omega = \frac{\pi V}{2 * V_A} \text{ radians per second;}$$

Where;

$V$  = the speed of the aeroplane at entry to the manoeuvre.

$V_A$  = the design manoeuvring speed prescribed in JAR 25.335(c)

(ii) For nose up pitching manoeuvres the complete cockpit pitch control displacement history may be scaled down in amplitude to the extent just necessary to ensure that the positive limit load factor prescribed in JAR 25.337 is not exceeded. For nose-down pitching manoeuvres the complete cockpit control displacement history may be scaled down in amplitude to the extent just necessary to ensure that the normal acceleration at the c.g. does not go below 0g.

(iii) In addition, for cases where the aeroplane response to the specified cockpit pitch control motion does not achieve the prescribed limit load factors then the following cockpit pitch control motion must be used:

$$\begin{aligned} \delta(t) &= \delta_1 * \sin(\omega t) && \text{for } 0 \leq t \leq t_1 \\ \delta(t) &= \delta_1 && \text{for } t_1 \leq t \leq t_2 \\ \delta(t) &= \delta_1 * \sin(\omega[t+t_1-t_2]) && \text{for } t_2 \leq t \leq t_{\max} \end{aligned}$$

Where;

$$t_1 = \pi/2\omega$$

Disclaimer – This document is not exhaustive and it will be updated gradually.



$$t_2 = t_1 + \Delta t$$

$$t_{MAX} = t_2 + \pi/\omega$$

$\Delta t$  = the minimum period of time necessary to allow the prescribed limit load factor to be achieved in the initial direction, but it need not exceed five seconds (see figure below).

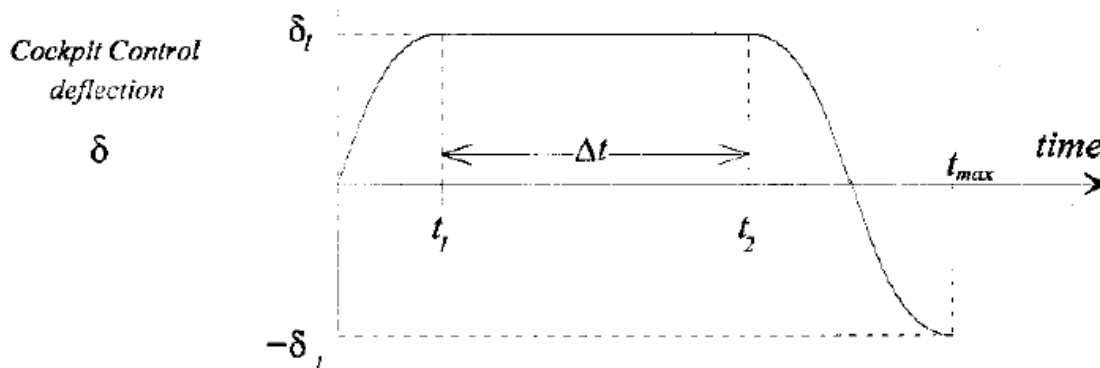

(iv) In cases where the cockpit pitch control motion may be affected by inputs from systems (for example, by a stick pusher that can operate at high load factor as well as at 1g) then the effects of those systems shall be taken into account.

(v) Aeroplane loads that occur beyond the following times need not be considered:

(1) For the nose-up pitching manoeuvre, the time at which the normal acceleration at the e.g. goes below 0g:

(2) For the nose-down pitching manoeuvre, the time at which the normal acceleration at the c.g. goes above the positive limit load factor prescribed in JAR 25.337;

(3)  $t_{max}$

## 2. Delete ACJ 25.331(c)(2).

### Acronyms and Abbreviations

<b>JAR</b>	Joint Aviation Regulation
<b>ACJ</b>	Advisory Circular Joint
<b>FAA</b>	Federal Aviation Administration
<b>ARAC</b>	Aviation Rulemaking Advisory Committee
<b>SSG</b>	Structures Study Group
<b>JAA</b>	Joint Aviation Authorities
<b>NPA</b>	Notice of Proposed Amendment

Disclaimer – This document is not exhaustive and it will be updated gradually.



## A-1017: BRAKED ROLL CONDITIONS

<b>SPECIAL CONDITION</b>	<b>A-1017: Braked Roll conditions</b>
APPLICABILITY:	A340-500/-600
REQUIREMENTS:	JAR 25.493
ISSUE:	2 dated 17/07/2000

### Special Condition summary

## BACKGROUND

The braked roll conditions of NPA 25C-276 and JAR 25 Change 14 plus OP 96/1 are very similar, having the same intent, and would give the same level of safety. The major change is to bring the existing conditions of ACJ 25.493(d) into the body of the rule, thereby setting a minimum strength standard.

NPA 25C-276 was produced by the JAA Structures Study Group (SSG) as a result of the harmonisation activity under the auspices of the ARAC Loads and Dynamics Harmonisation Working Group, in which members of the SSG participated. The NPA 25C-276 has the intent of harmonising the JAR 'Braked Roll Conditions' requirements with those of the FAR requirements. The NPA was fully accepted through the JAA amendment process but was published much later in JAR Change 15.

Therefore the NPA 25C-276 was accepted on an elect to comply basis for inclusion in A340-500/-600 Joint Type Certification Basis.

## SPECIAL CONDITION

### 1. JAR 25.493 is amended by revising sub-paragraphs (c) and (d) and by adding a new sub-paragraph (e) to read as follows:

JAR 25.493 Braked roll conditions.

(c) A drag reaction lower than that prescribed in this paragraph may be used if it is substantiated that an effective drag force of 0.8 times the vertical reaction cannot be attained under any likely loading condition. (See ACJ 25.493(c)).

(d) An aeroplane equipped with a nose gear must be designed to withstand the loads arising from the dynamic pitching motion of the aeroplane due to sudden application of maximum braking force. The aeroplane is considered to be at design take-off weight with the nose and main gears in contact with the ground, and with a steady state vertical load factor of 1.0. The steady state nose gear reaction must be combined with the maximum incremental nose gear vertical reaction caused by sudden application of maximum braking force as described in paragraphs (b) and (c) of this section.

Disclaimer – This document is not exhaustive and it will be updated gradually.



(e) In the absence of a more rational analysis, the nose gear vertical reaction prescribed in paragraph (d) of this section must be calculated in accordance with the following formula:

$$V_N = \frac{W\tau}{A+B} * (B + \frac{f*\mu*A*E}{A+B+\mu*E})$$

Where:

$V_N$  = Nose gear vertical reaction

$W_\zeta$  = Design take-off weight

A = Horizontal distance between the e.g. of the aeroplane and the nose wheel

B = Horizontal distance between the e.g. of the aeroplane and the line joining the centres of the main wheels.

E = Vertical height of the e.g. of the aeroplane above the ground in the 1.0g static condition.

$\mu$  = Coefficient of friction of 0.8

f = Dynamic response factor; 2.0 is to be used unless a lower factor is substantiated.

In the absence of other information, the dynamic response factor f may be defined by the equation:

$$f = 1 + \exp\left(\frac{-\pi\varepsilon}{\sqrt{1-\varepsilon^2}}\right)$$

Where:  $\varepsilon$  is the critical damping ratio of the rigid body pitching mode about the main landing gear effective ground contact point.

## 2. Existing ACJ 25.493(d) is deleted.

### Acronyms and Abbreviations

<b>JAR</b>	Joint Aviation Regulation
<b>NPA</b>	Notice of Proposed Amendment
<b>OP</b>	Orange Paper
<b>ACJ</b>	Advisory Circular Joint
<b>SSG</b>	Structures Study Group
<b>ARAC</b>	Aviation Rulemaking Advisory Committee
<b>FAR</b>	Federal Aviation Regulations

Disclaimer – This document is not exhaustive and it will be updated gradually.



## A-1020: LANDING GEAR SHOCK ABSORPTION TESTS

<b>SPECIAL CONDITION</b>	<b>A-1020: Landing Gear Shock Absorption Tests</b>
APPLICABILITY:	A340-500/-600
REQUIREMENTS:	JAR 25.473, 25.723, 25.725, 25.727
ISSUE:	3 dated 23/01/2001

### Special Condition summary

#### BACKGROUND

The shock absorption test requirements of NPA 25CD-279 provide for a different objective of the landing gear energy absorption tests than the JAR 25 Change 14 plus JAR Amendment 25/96/1 requirements, i.e. to validate the landing gear dynamic characteristics rather than directly determine landing gear factors. NPA 25CD-279 is therefore consistent with improvements in the landing load requirements that necessitate an accurate representation of the landing gear shock absorption characteristics.

NPA 25CD-279 was produced by the JAA Structures Study Group (SSG) as a result of the harmonisation activity under the auspices of the ARAC Loads and Dynamics Harmonisation Working Group, in which members of the SSG participated. The NPA 25CD-279 has the intent of harmonising the JAR shock absorption tests requirements with those of the FAR. The NPA was fully accepted through the JAA amendment process and was published much later in JAR 25 Change 15. The harmonised shock absorption tests requirements were published in the Federal Register with NPRM 99-08.

Therefore the NPA 25CD-279 was accepted on an elect to comply basis for inclusion in A340-500/-600 Joint Type Certification Basis.

#### SPECIAL CONDITION

**1. Amend JAR 25.473 by revising sub-paragraph (d) to read as follows:**

(d) The landing gear dynamic characteristics must be validated by tests as defined in JAR 25.723(a)

**2. Amend JAR 25.723 by, revising sub-paragraph (a) to read as follows:**

JAR 25.723 Shock Absorption Tests

(a) The landing gear dynamic characteristics used for design must be validated by energy absorption tests. The dynamic characteristics must be substantiated for the range of landing conditions, aeroplane configurations, and service variations expected in operation.

Disclaimer – This document is not exhaustive and it will be updated gradually.



- (1) The configurations subjected to energy absorption tests must include at least the maximum landing weight or the maximum take-off weight, whichever produces the greater value of landing impact energy.
- (2) The test attitude of the landing gear unit and the application of appropriate drag loads during the test must simulate the aeroplane landing conditions in a manner consistent with the development of rational or conservative limit loads.
- (3) Changes in previously approved design weights and minor changes in design may be substantiated by analyses based on previous tests conducted on the same basic landing gear system that has similar energy absorption characteristics.

**2. Remove JAR 25.725 "Limit drop tests" and mark it reserved.**

**3. Remove JAR 25.727 "Reserve energy absorption drop tests" and mark it reserved.**

### Acronyms and Abbreviations

<b>JAR</b>	Joint Aviation Regulation
<b>ACJ</b>	Advisory Circular Joint
<b>NPA</b>	Notice of Proposed Amendment
<b>JAA</b>	Joint Aviation Authorities
<b>SSG</b>	Structures Study Group
<b>ARAC</b>	Aviation Rulemaking Advisory Committee
<b>FAR</b>	Federal Aviation Regulations
<b>NPRM</b>	New Proposal Rule Making

Disclaimer – This document is not exhaustive and it will be updated gradually.





## A-1021: ENGINE FAILURE LOADS

Equivalent Safety Finding	A-1021: Engine failure Loads
APPLICABILITY:	A340-500/A340-600
REQUIREMENTS:	JAR 25.361 (b), (c) and (d)
ISSUE:	3 dated 27/09/2001

### Equivalent Safety Finding summary

#### BACKGROUND

JAR 25.361 (b) at change 14 plus OP 96/1 requires that “For turbine engines and auxiliary power unit installations, the limit torque load imposed by sudden stoppage due to a malfunction or structural failure ( such as compressor jamming) must be considered in the design of engine and auxiliary power unit mounts and supporting structure. In the absence of better information a sudden stoppage must be assumed to occur in 3 seconds”.

The size, configuration, and failure modes of jet engines have changed considerably since JAR 25.361(b) was first adopted.

Relative to the engine configurations that existed when the rule was first developed, these later generations of jet engines are sufficiently different and novel to justify amending the regulations to ensure that adequate design standards are available for the mounts and the structure supporting these newer engines. Therefore, in order to maintain the level of safety intended by JAR 25.361(b), it is considered that a more comprehensive criterion is necessary one that considers all load components when designing to address engine failure events.

Studies made by the engine and the airframe manufacturers have shown that large turbofan engines exhibit two distinct classes of sudden deceleration events:

- Transient deceleration conditions involving rapid slowing of the rotating system
- Engine failures that result in extensive engine damage and permanent loss of thrust – producing capability

Accordingly, an amendment of JAR 25.361 and a new JAR 25.362 with ACJ 25.362 addressing engine failure loads, which would distinguish between design criteria for the more common failure events (first type of event) and design criteria for those rare events resulting from structural failures (second type of event).

#### EQUIVALENT SAFETY FINDING

##### JAR. 25.361 Engine and auxiliary power unit torque

- a) Each engine mount and its supporting structure must be designed for the effects of:
  - 1) A limit engine torque corresponding to take-off power and propeller speed acting simultaneously with 75 percent of the limit loads from flight condition A of JAR 25.333(b);

Disclaimer – This document is not exhaustive and it will be updated gradually.



- 2) A limit torque corresponding to the maximum continuous power and propeller speed, acting simultaneously with the limit loads from flight condition A of JAR 25.333(b); and
  - 3) For turbo propeller installations, in addition to the conditions specified in subparagraphs (a)(1) and (a)(2), a limit engine torque corresponding to take-off power and propeller speed, multiplied by a factor accounting for propeller control system malfunction, including quick feathering, acting simultaneously with 1g level flight loads. In the absence of a rational analysis, a factor of 1.6 must be used.
- b) The limit engine torque to be considered under subparagraph (a) must be obtained by multiplying mean torque for the specified power and speed by a factor of:
- 1) 1.25 for turbo propeller installations;
  - 2) 1.33 for reciprocating engines.
- c) For turbine engine installations, the engine mounts, pylons, and adjacent supporting airframe structure must be designed to withstand 1g level flight loads acting simultaneously with the maximum limit torque loads imposed by each of the following:
- 1) Sudden engine deceleration due to a malfunction which could result in a temporary loss of power or thrust; and
  - 2) The maximum acceleration of the engine.
- d) For auxiliary power unit installations, the power unit mounts and adjacent supporting airframe structure must be designed to withstand 1g level flight loads acting simultaneously with the maximum limit torque loads imposed by each of the following:
- 1) Sudden APU deceleration due to malfunction or structural failure; and
  - 2) The maximum acceleration of the power unit.

#### **JAR. 25.362 Engine failure loads**

- a) For engine supporting structure, an ultimate Loading condition must be considered that combines 1g flight loads with the transient dynamic loads resulting from:
  - 1) The loss of any fan, compressor, or turbine blade; and
  - 2) Separately, where applicable to a specific engine design, any other engine structural failure that results in higher loads.
- b) The ultimate loads developed from the conditions specified in paragraph (a) are to be:
  - 1) Multiplied by a factor of 1.0 when applied to engine mounts and pylons; and
  - 2) Multiplied by a factor of 1.25 when applied to adjacent supporting airframe structure.

#### **Acronyms and Abbreviations**

<b>JAR</b>	Joint Aviation Regulation
<b>ACJ</b>	Advisory Circular Joint
<b>OP</b>	Orange Paper

Disclaimer – This document is not exhaustive and it will be updated gradually.



## A-1023: CONTINUOUS TURBULENCE LOADS

Equivalent Safety Finding	A-1023: Continuous Turbulence Loads
APPLICABILITY:	A340-500/-600
REQUIREMENTS:	JAR 25.341(b)
ISSUE:	2 dated 27/11/2000

### Equivalent Safety Finding summary

## BACKGROUND

A340-500/-600 applicable Type Certification Basis is JAR 25 at change 14 plus JAR Amendment 25/96/1.

Current JAR 25.341 (b) requires that "The dynamic response to symmetrical vertical and lateral continuous turbulence must be taken into account (See ACJ 25.341(b))". ACJ 25.341(b) provides acceptable criteria for assessing the effects of dynamic response to continuous turbulence.

Airbus has proposed a special condition to JAR 25.341(b) at change 14 and proposes to show compliance to JAR 25. 341(b) using the harmonised position between JAA and FAA as established within the ARAC Loads and Dynamics Harmonisation Working Group.

## EQUIVALENT SAFETY FINDING

### 4. PROPOSALS

#### 1. To amend JAR 25.341 by revising subparagraph 25.341(a)(5)(i) to read as follows:

(a) \* \* \* \* \*

(5) The following reference gust velocities apply:

(i) At aeroplane speeds between  $V_B$  and  $V_C$ :

Positive and negative gusts with reference gust velocities of 56.0 ft./sec EAS must be considered at sea level. The reference gust velocity may be reduced linearly from 56.0 ft./sec EAS at sea level to 44.0 ft./sec EAS at 15 000 feet. The reference gust velocity may be further reduced linearly from 44.0 ft./sec EAS at 15 000 feet to 20.86 ft./sec EAS at 60 000 feet.

#### 2. To amend JAR 25.341 by revising subparagraph 25.341(b) and subparagraph 25.341(c) to read as follows:

(b) *Continuous Turbulence Design Criteria.* The dynamic response of the aeroplane to vertical and lateral continuous turbulence must be taken into account. The dynamic analysis must take into account unsteady aerodynamic characteristics and all significant structural degrees of

Disclaimer – This document is not exhaustive and it will be updated gradually.



freedom including rigid body motions. The limit loads must be determined for all critical altitudes, weights, and weight distributions as specified in JAR 25.321(b), and all critical speeds within the ranges indicated in subparagraph (b)(3).

(1) Except as provided in subparagraphs (b)(4) and (b)(5) of this paragraph, the following equation must be used:

$$P_L = P_{L-1g} \pm U_\sigma \bar{A}$$

Where:

- $P_L$  = limit load;
- $P_{L-1g}$  = steady 1- g load for the condition;
- $\bar{A}$  = ratio of root-mean-square incremental load for the condition to root-mean-square turbulence velocity; and
- $U_\sigma$  = limit turbulence intensity in true airspeed, specified in subparagraph (b)(3) of this paragraph.

(2) Values of  $\bar{A}$  must be determined according to the following formula:

$$\bar{A} = \sqrt{\int_0^\infty |H(\Omega)|^2 \phi(\Omega) d\Omega}$$

Where:

- $H(\Omega)$  = the frequency response function, determined by dynamic analysis, that relates the loads in the aircraft structure to the atmospheric turbulence; and
- $\phi(\Omega)$  = normalised power spectral density of atmospheric turbulence given by:

$$\phi(\Omega) = \frac{L(1 + \frac{8}{3}(1.339\Omega L)^2)}{\pi(1 + (1.339\Omega L)^2)^{11/6}}$$

Where:

- $\Omega$  = reduced frequency, radians per foot; and
- $L$  = scale of turbulence = 2.500 ft.

(3) The limit turbulence intensities,  $U_\sigma$ , in feet per second true airspeed required for compliance with this paragraph are:

- (i) At aeroplane speeds between  $V_B$  and  $V_C$ :

$$U_\sigma = U_{\sigma ref} Fg$$

Where:

- $U_{\sigma ref}$  is the reference turbulence intensity that varies linearly with altitude from 90 fps (TAS) at sea level to 79 fps (TAS) at 24000 feet and is then constant at 79 fps (TAS) up to the altitude of 60 000 feet; and
- $Fg$  is the flight profile alleviation factor defined in subparagraph (a)(6) of this paragraph:

Disclaimer – This document is not exhaustive and it will be updated gradually.



- (ii) At speed  $V_D$ :  $U_\sigma$  is equal to 1/2 the values obtained under subparagraph (3)(i) of this paragraph.
- (iii) At speeds between  $V_C$  and  $V_D$ :  $U_\sigma$  is equal to a value obtained by linear interpolation.
- (iv) At all speeds both positive and negative continuous turbulence must be considered.

(4) When an automatic system affecting the dynamic response of the aeroplane is included in the analysis, the effects of system non-linearities on loads at the limit load level must be taken into account in a realistic or conservative manner.

(5) If necessary for the assessment of loads on aeroplanes with significant non-linearities, it must be assumed that the turbulence field has a root-mean-square velocity equal to 40 percent of the  $U_\sigma$  values specified in subparagraph (3). The value of limit load is that load with the same probability of exceedance in the turbulence field as  $\bar{A}U_\sigma$  of the same load quantity in a linear approximated model.

(c)Supplementary gust conditions for wing mounted engines. For aeroplanes equipped with wing mounted engines, the engine mounts, pylons, and wing supporting structure must be designed for the maximum response at the nacelle centre of gravity derived from the following dynamic gust conditions applied to the aeroplane:

(1) A discrete gust determined in accordance with JAR 25.341(a) at each angle normal to the flight path, and separately,

(2) A pair of discrete gusts, one vertical and one lateral. The length of each of these gusts must be independently tuned to the maximum response in accordance with JAR 25.341(a). The penetration of the aeroplane in the combined gust field and the phasing of the vertical and lateral component gusts must be established to develop the maximum response to the gust pair. In the absence of a more rational analysis, the following formula must be used for each of the maximum engine loads in all six degrees of freedom:

$$P_L = P_{L-1g} + 0.85 \sqrt{Lv^2 + Ll^2}$$

Where:

- $P_L$  = limit load;
- $P_{L-1g}$  = steady 1- g load for the condition;
- $Lv$  = peak incremental response load due to a vertical gust according to JAR 25.341(a);
- $Ll$  = peak incremental response load due to a lateral gust according to JAR 25.341(a)

### 3. To amend JAR 25.343 by revising subparagraph 25.343(b)(1)(ii) to read as follows:

(b) \* \* \* \* \*

Disclaimer – This document is not exhaustive and it will be updated gradually.



(1) \* \* \* \* \*

- (ii) The gust and turbulence conditions of JAR 25.341, but assuming 85% of the gust velocities prescribed in JAR 25.341(a)(4) and 85% of the turbulence intensities prescribed in JAR 25.341(b)(3).

**4. To amend JAR 25.345 by revising subparagraph 25.345(c)(2) to read as follows:**

(c) \* \* \* \* \*

5. The vertical gust and turbulence conditions prescribed in JAR 25.341.

**5. To amend JAR 25.371 to read as follows:**

JAR 25.371 Gyroscopic loads.

The structure supporting any engine or auxiliary power unit must be designed for the loads, including gyroscopic loads, arising from the conditions specified in JAR 25.331, JAR 25.341, JAR 25.349, JAR 25.351, JAR 25.473, JAR 25.479, and JAR 25.481, with the engine or auxiliary power unit at the maximum rpm appropriate to the condition. For the purposes of compliance with this paragraph, the pitch manoeuvre in JAR 25.331(c)(1) must be carried out until the positive limit manoeuvring load factor (point  $A_2$  in JAR 25.333(b)) is reached.

**6. To amend JAR 25.373 by revising subparagraph 25.373(a) to read as follows:**

- (a) The aeroplane must be designed for the symmetrical manoeuvres and gusts prescribed in JAR 25.333, JAR 25.337, the yawing manoeuvres in JAR 25.351, and the vertical and lateral gust and turbulence conditions prescribed in JAR 25.341(a) and (b) at each setting and the maximum speed associated with that setting; and:

\* \* \* \* \*

**7. To amend JAR 25.391 to read as follows:**

JAR 25.391 Control surface loads: general

The control surfaces must be designed for the limit loads resulting from the flight conditions in JAR 15.331, JAR 25.341(a) and (b), JAR 25.349 and JAR 25.351 and the ground gust conditions in JAR 25.415, considering the requirements for-----

\* \* \* \* \*

**8. To amend JAR 25.1517 to read as follows:**

JAR25.1517 Rough airspeed  $V_{RA}$

- (a) A rough air speed  $V_{ra}$ , for use as the recommended turbulence penetration air speed, and a rough air Mach number  $M_{ra}$ , for use as the recommended turbulence penetration Mach number, must be established to ensure that likely speed variation during rough air encounters will not cause the overspeed warning to operate too frequently.

Disclaimer – This document is not exhaustive and it will be updated gradually.



(b) At altitudes where  $V_{mo}$  is not limited by Mach number, in the absence of a rational investigation substantiating the use of other values,  $V_{ra}$  must be less than  $V_{mo} - 35$  KTAS.

(c) At altitudes where  $V_{mo}$  is limited by Mach number,  $M_{ra}$  may be chosen to provide an optimum margin between low and high speed buffet boundaries.

### Acronyms and Abbreviations

<b>JAR</b>	Joint Aviation Regulation
<b>ACJ</b>	Advisory Circular Joint
<b>JAA</b>	Joint Aviation Authorities
<b>FAA</b>	Federal Aviation Administration
<b>ARAC</b>	Aviation Rulemaking Advisory Committee
<b>EAS</b>	Equivalent Air-Speed
<b>TAS</b>	True Airspeed
<b>KTAS</b>	Knots True Airspeed

Disclaimer – This document is not exhaustive and it will be updated gradually.



## A-1024: CASTING FACTORS

<b>SPECIAL CONDITION</b>	<b>A-1024: Casting Factors</b>
APPLICABILITY:	A340-500/-600
REQUIREMENTS:	JAR 25.621
ISSUE:	2 dated 26/07/2001

### Special Condition summary

## BACKGROUND

A340-500/-600 applicable Type Certification Basis is JAR 25 at change 14 plus JAR Amendment 25/96/1.

Current JAR 25.621 states that "The approved national standards of the participants are accepted by the Authorities as alternatives to FAR 25.621".

Airbus has requested a special condition to show compliance to JAR 25. 621 using the harmonised position between JAA and FAA as established within the ARAC General Structures Harmonisation Working Group.

## SPECIAL CONDITION

**In lieu of §25.621 "Casting Factors" the following apply:**

JAR 25.621 Casting factors.

(a) *General.* For castings used in structural applications, the factors, tests, and inspections specified in sub-paragraphs (b) through (d) of this paragraph must be applied in addition to those necessary to establish foundry quality control. The inspections must meet approved specifications.

Sub-paragraphs (c) and (d) of this paragraph apply to any structural castings except castings that are pressure tested as parts of hydraulic or other fluid systems and do not support structural loads.

(b) *Bearing stresses and surfaces.* The casting factors specified in sub-paragraph (c) of this paragraph:

- (1) Need not exceed 1.25 with respect to bearing stresses regardless of the method of inspection used; and
- (2) Need not be used with respect to the bearing surfaces of a part whose bearing factor is larger than the applicable casting factor.

3. *General.* The objective of a premium casting process is to consistently produce castings with high quality and reliability. To this end, the casting process is one that is capable of consistently producing castings that include the following characteristics:

Disclaimer – This document is not exhaustive and it will be updated gradually.





- Good dimensional tolerance
- Minimal distortion
- Good surface finish
- No cracks
- No cold shuts
- No laps
- Minimal shrinkage cavities
- No harmful entrapped oxide films
- Minimal porosity
- A high level of metallurgical cleanliness
- Good microstructural characteristics
- Minimal residual internal stress
- Consistent mechanical properties

The majority of these characteristics can be detected, evaluated, and quantified by standard non-destructive testing methods, or from destructive methods on prolongation or casting cut-up tests. However, a number of them cannot. Thus, to ensure an acceptable quality of product, the significant and critical process variables must be identified and adequately controlled.

#### 4. A Means of Qualification of Casting Process.

4.1 To prove a premium casting process, the applicant should submit it to a qualification program that is specific to a foundry/material combination. The qualification program should establish the following:

- (a) The capability of the casting process of producing a consistent quality of product for the specific material grade selected for the intended production component.
- (b) The mechanical properties for the material produced by the process have population coefficients of variation equivalent to that of wrought products of similar composition (i.e. plate, extrusions, and bar). Usage of the population coefficient of variation from forged products does not apply.
- (c) The casting process is capable of producing a casting with uniform properties throughout the casting or, if not uniform, with a distribution of material properties that can be predicted to an acceptable level of accuracy.
- (d) The (initial) material design data for the specified material are established.
- (e) The material and process specifications are clearly defined.

4.2 For each material specification, a series of standard test castings from a number of melts, using the appropriate production procedures of the foundry, should be manufactured. The standard test casting produced should undergo a standardised inspection or investigation of non-destructive inspection and cut-up testing, to determine the consistency of the casting process.

4.3 The standard test casting should be representative of the intended cast product(s), and should expose any limitations of the casting process. In addition, the standard test casting should be large enough to provide mechanical test specimens from various areas, for tensile and, if applicable, compression, shear, bearing, fatigue, fracture toughness, and crack propagation tests. If the

Disclaimer – This document is not exhaustive and it will be updated gradually.



production component complies with these requirements, it may be used to qualify the process. The number of melts sampled should be statistically significant. Typically, at least 10 melts are sampled, with no more than 10 castings produced from each melt. If the material specification requires the components to be heat-treated, this should be done in no fewer than 10 heat treatment batches consisting of castings from more than one melt. Reduction of qualification tests may be considered if the casting process and the casting alloy is already well known for aerospace applications and the relevant data are available.

4.4 Each standard test casting should receive:

- Inspection of 100% of its surface, using visual and liquid penetrant, or equivalent, inspection methods; and
- Inspection of structurally significant internal areas and areas where defects are likely to occur, using radiography methods or equivalent inspection methods. The specific radiography standard to be employed is to be determined, and the margin by which the standard test castings exceed the minimum required standard should be recorded.

(a) The program of inspection is intended to confirm the consistency of the casting process, as well as to ensure the stated objectives on surface finish, cracks, cold shuts, laps, shrinkage cavities, and porosity.

(b) In addition, the program of inspection is to ensure that the areas from which the mechanical property samples were taken were typical of the casting as a whole with respect to porosity and clearness.

4.5 All standard test castings should be cut up to a standardised methodology to produce the mechanical test specimens detailed above. Principally, the tests are to establish the variability within the cast component, as well as to determine the variability between components from the same melt and from melt to melt. The data gathered also may be used during latter phases to identify deviations from the limits established in the process qualification and product proving programs.

4.6 All the fracture surfaces generated during the qualification program should be inspected at least visually for detrimental defects.

4.7 As part of the cut-up investigation, it is usually necessary to take metallography samples for clearness determination and microstructural characterisation.

4.9 When the process has been qualified, it should not be altered without completing comparability studies and necessary testing of differences.

## 5. Proof of Product

5.1 Subsequent to the qualification of the process, the production castings should be subjected to a production proving program. Such castings should have at least one prolongation; however, large and/or complex castings may require more than one. If a number of castings are produced from a

Disclaimer – This document is not exhaustive and it will be updated gradually.



---

single mould with a single runner system, they may be treated as one single casting. The production proving program should establish the following:

- (a) The design values developed during the process qualification program are valid (e.g. same statistical distribution) for the production casting.
- (b) The production castings have the same or less than the level of internal defects as the standard test castings produced during qualification.
- (c) The cast components have a predictable distribution of tensile properties.
- (d) The prolongation(s) is representative of the critical area(s) of the casting.
- (e) The prolongation(s) consistently reflects the quality process, and material properties of the casting.

5.2 A number of (i.e., at least two) pre-production castings of each part number to be produced should be selected for testing and inspection. All of the selected castings should be non-destructively inspected in accordance with the qualification program.

- (a) One of these castings should be used as a dimensional tolerance test article. The other selected casting(s) should be cut up for mechanical property testing and metallography inspection.
- (b) The casting(s) should be cut up to a standardised program to yield a number of tensile test specimens and metallography samples. There should be sufficient cut-up tensile specimens to cover all critical (“critical” with respect to both the casting process and service loading) areas of the casting.
- (c) All prolongations should be machined to give tensile specimens, and subsequently tested.
- (d) The production castings should be produced to production procedures identical to those used for these pre-production castings.

5.3 On initial production a number of castings should undergo a cut-up for mechanical property testing and metallography inspection, similar to that performed for the pre-production casting(s). The cut-up procedure used should be standardised, although it may differ from that used for the preproduction casting(s). Tensile specimens should be obtained from the most critical areas.

- (a) For the first 30 castings produced, at least 1 casting in 10 should undergo this testing program.
- (b) The results from the mechanical property tests should be compared with the results obtained from the prolongations to further substantiate the correlation between prolongation(s) and the critical area(s) of the casting.
- (c) In addition, if the distribution of mechanical properties derived from these tests is acceptable, when compared to the property values determined in the qualification program, the frequency of testing may be reduced. However, if the comparison is found not to be acceptable, the test program may require extension.

Disclaimer – This document is not exhaustive and it will be updated gradually.



5.4 At no point in the production should the castings contain shrinkage cavities, cracks, cold shuts, laps, porosity, or entrapped oxide film, or have a poor surface finish, exceeding the acceptance level defined in the technical specifications.

## 6. *Monitoring the Process.*

6.1 The applicant should employ quality techniques to establish the significant/critical foundry process variables that have an impact on the quality of the product. The applicant should show that these variables are controlled with positive corrective action throughout production.

6.2 During production, every casting should be non-destructively inspected using the techniques and the acceptance standards employed during the qualification program.

- (a) Rejections should be investigated and process corrections made as necessary.
- (b) Alternative techniques may be employed if the equivalence in the acceptance levels can be demonstrated.
- (c) In addition, tensile tests should be taken from the prolongations on every component produced and the results should comply with limits developed in the process qualification and product proving programs.
- (d) Additionally, as previously mentioned, a periodic casting cut up inspection should be undertaken, with the inspection schedule as agreed upon during the proof of product program.
- (e) Deviations from the limits established in the process qualification and product proving programs should be investigated and corrective action taken.

## 7. *Modifications to the Casting Design, Material, and Process.*

7.1 Additional testing may be required when alterations are made to the casting geometry, material, significant/critical process variables, process, or production foundry to verify that the alterations have not significantly changed the castings' properties. The verification testing recommended is detailed in Table 1, below:

Disclaimer – This document is not exhaustive and it will be updated gradually.



Table 1: Recommended Verification Testing

Case	Qualifications				Verification Testing		
	Geometry	Material	Process	Foundry	Qualification of Process	Proof of Product	Tests per § 25.621(e)(1)
1	yes	none	none	none	not necessary	yes	yes (b)
2	none	yes	none	none	yes (a)	yes	yes (b)
3	yes	yes	none	none	yes	yes	yes
4	none	none	yes	none	yes (a)	yes	yes (b)
5	none	none	none	yes	yes (a)	yes	yes (b)

(a) The program described in paragraph 4. of this ACJ to qualify a new material, process, and foundry combination may not be necessary if the following 3 conditions exist for the new combination:

- (1) Sufficient data from relevant castings to show that the process is capable of producing a consistent quality of product, and that the quality is comparable to or better than the old combination.
- (2) Sufficient data from relevant castings to establish that the mechanical properties of the castings produced from the new combination have a similar or better statistical distribution than the old combination.
- (3) Clearly defined material and process specifications.

(b) The casting may be re-qualified by testing partial static test samples (with larger castings, re-qualification could be undertaken by a static test of the casting's critical region only); this should be approved.

## Acronyms and Abbreviations

<b>ARAC</b>	Aviation Rulemaking Advisory Committee
<b>FAA</b>	Federal Aviation Administration
<b>JAR</b>	Joint Aviation Regulation
<b>FAR</b>	Federal Aviation Regulations

Disclaimer – This document is not exhaustive and it will be updated gradually.



## A-1026: PROOF OF STRUCTURE

<b>SPECIAL CONDITION</b>	<b>A-1026: Proof of Structure</b>
APPLICABILITY:	A340-500/-600
REQUIREMENTS:	JAR 25.307(a)
ISSUE:	2 dated 27/11/2000

### Special Condition summary

## BACKGROUND

A340-500/-600 applicable Type Certification Basis is JAR 25 at change 14 plus JAR Amendment 25/96/1.

Airbus has requested Special Condition to JAR 25.307 as interpreted with current ACJ 25 307 at change 14 plus OP 96/1 and proposes to show compliance to JAR 25.307 using the harmonised position between JAA and FAA as established within the ARAC Loads and Dynamics harmonisation Working Group.

## SPECIAL CONDITION

### Amend JAR 25.307 as follows:

JAR 25.307 Proof of structure (See ACJ 25.307)

- (a) Compliance with the strength and deformation requirements of this Subpart must be shown for each critical loading condition. Structural analysis may be used only if the structure conforms to that for which experience has shown this method to be reliable. In other cases, substantiating tests must be made that are sufficient to verify structural behaviour up to the load levels required by JAR 25.305. Where it is justified, these test load levels may be reduced.
- (b) \* \* \*
- (c) \* \* \*
- (d) \* \* \*

## Acronyms and Abbreviations

<b>JAR</b>	Joint Aviation Regulation
<b>ACJ</b>	Advisory Circular Joint
<b>OP</b>	Orange Paper
<b>JAR</b>	Joint Aviation Regulation
<b>ARAC</b>	Aviation Rulemaking Advisory Committee

Disclaimer – This document is not exhaustive and it will be updated gradually.



**CCD-01: DETERMINATION OF CERTIFICATION BASIS FOR CHANGES TO A340 CCD**

<b>SPECIAL CONDITION</b>	<b>CCD-01: Determination of Certification Basis for changes to A340 CCD</b>
APPLICABILITY:	A340
REQUIREMENTS:	PART 21A.101
ISSUE:	1 dated 14/08/2017

**Special Condition summary**

**BACKGROUND**

The Special Condition A-01-CCD currently establishes the certification basis for the grandfathered (initial) Cabin Crew Data (CCD) of the A330 and A340 aircraft models and limits the CCD scope to:

- the aircraft type determination for cabin crew, and
- the establishment of recommendations to support the establishment by operators, of cabin crew differences training programs for variants.

The certification of A340 future design changes requires the establishment of cabin crew operational data to be implemented in the cabin crew training and operating manual by operators.

The special condition below comes in addition to the SC A-01-CCD.

**SPECIAL CONDITION**

CASE (Cabin Aspects of Special Emphasis) are information relevant to the aircraft type design that cabin crew need to be aware of to ensure the safe operation of the aircraft. A CASE is established when:

- A novel and unique design or operational characteristic is applicable to an aircraft type, variant or modification (or a group of aircraft types), and
- Specific knowledge and skills are required for the safe operation of this novel and unique design or operational characteristic.

CASE are limited to novel, unconventional safety-related elements in the passenger cabin, that affect the cabin crew duties and for which cabin crew have to be informed on how to operate the element.

These safety-related elements of the passenger cabin are:

- doors and exits
- assisting evacuation means (slide, slideraft, etc.)
- emergency lighting system
- evacuation alarm signal system
- smoke detection system
- automatic fire extinguishing system
- drop-down oxygen system

Disclaimer – This document is not exhaustive and it will be updated gradually.





- 
- communication and public address system
  - information and control panels related to the above listed systems
  - number of aisles
  - number of decks
  - any design features that impact emergency operations (e.g. emergency evacuation).

CASE constitute CCD and shall be made available to operators (in addition to the A340 initial CCD), for post-TC changes.

### Acronyms and Abbreviations

<b>CASE</b>	Cabin Aspects of Special Emphasis
<b>CCD</b>	Cabin Crew Data
<b>OSD</b>	Operational Suitability Data

Disclaimer – This document is not exhaustive and it will be updated gradually.





## D-100: INSTALLATION OF MINI-SUITE TYPE SEATING

<b>SPECIAL CONDITION</b>	<b>D-100: Installation of mini-suite type seating</b>
APPLICABILITY:	A330/A340
REQUIREMENTS:	JAR 25.785(h)(2), 25.813(e)
ISSUE:	Issue 1 dated 30/04/2018

### Special Condition summary

#### BACKGROUND

This Special Conditions applies to mini-suites which are design features with a partial height partition that will surround an occupant providing additional comfort, convenience, and privacy (Complete enclosure may be achieved by moving sliding partition element(s)).

#### SPECIAL CONDITION

1. Only single occupancy of the Mini-suite is allowed during taxi, take-off and landing.
2. The mini-suite entrance must only provide access to the specific mini-suite.
3. Mini-suites must not provide the required egress path for any passenger other than for its single occupant.
4. Installation of the mini-suites must not introduce any additional obstructions or diversions to evacuating passengers, even from other parts of the cabin.
5. The design of the doors and surrounding "furniture" above the cabin floor in the aisles must be such that each passenger's actions and demeanour can be readily observed by cabin crew members with stature as low as the 5th percentile female.
6. The mini-suite door(s) must be open during taxi, take-off and landing.
7. A hold open retention mechanism for mini-suite doors must be provided and must hold the doors open under JAR 25.561(b) emergency landing conditions.
8. There must be a secondary, backup hold open retention mechanism for the mini-suite doors that can be used to "lock" the doors in the open position if there is an electrical or mechanical failure of the primary retention mechanism. The secondary retention mechanism must hold the doors open under JAR 25.561(b) emergency landing conditions.
9. There must be a means to readily check that all mini-suite doors are fully open and in the latched condition.

Disclaimer – This document is not exhaustive and it will be updated gradually.



10. There must be means to prevent the seated mini-suite occupant from operating the doors and thus ensure that the doors remain open during the TTOL phases of the flight.
11. Appropriate placards, or other equivalent means, must be provided to ensure the mini-suite occupants know that the doors must be in the open position for taxi, take-off and landing.
12. Operating instruction materials necessary to provide adequate compliance with SC 5, 9 and 10, considering also the number of individual mini-suites, shall be discussed and agreed with EASA and shall be provided to the operator for incorporation into their cabin crew training programs and associated operational manuals. This may affect the minimum acceptable number of cabin crew required to operate the aeroplane.
13. In the TTOL configuration, the mini-suite must provide an unobstructed access to the main aisle having a width of at least 30 cm (12 inches) at a height lower than 64 cm (25 inches) from the floor, and of at least 38 cm (15 inches) at a height of 64 cm (25 inches) and more from the floor. A narrower width not less than 23 cm (9 inches) at a height below 64 cm (25 inches) from the floor may be approved when substantiated by tests found necessary by the Agency.
14. In addition, the mini-suite must have an Emergency Passage Feature (EPF) to allow for evacuation of the mini-suite occupant in the event a door closes and becomes jammed during an emergency landing. The EPF must provide a free aperture for passage into the aisle consistent with SC 13 or meeting the requirements of JAR 25.807 applicable to a Type IV size emergency exit.

If the EPF consists of frangible and/or removable elements they must be easily broken/removed by the occupant of the mini-suite when a door becomes jammed.

If an EPF consists of dual independent sliding doors opening in opposite directions, the remaining unobstructed access width with one door in the fully closed position must be consistent with SC 13 or meet the requirements of JAR 25.807 applicable to a Type IV size emergency exit .

The occupant of the mini-suite must be made aware of the EPF and its way of operation.

In no case shall the occupant using the EPF have to rely on another occupant to assist in passage.
15. The height of the mini suite walls and doors must be such that a 95th percentile male can fit between them and the aeroplane interior furnishing.
16. No mechanism to latch the door(s) in the closed position shall be provided.
17. The mini-suite door(s) must be openable from the inside or outside with 25 pounds force or less regardless of power failure conditions.
18. If the mini-suite doors are electrically powered, in the event of loss of power to the mini-suite with the door(s) open, the door(s) must remain latched in the open position.
19. The mini-suites installation must not encroach into any required main aisle, cross aisle or passage ways.

Disclaimer – This document is not exhaustive and it will be updated gradually.



- 
20. No mini-suite door may impede main aisle or cross aisle egress paths in the open, closed or translating position.
  21. The mini-suite doors must remain easily openable, even with a crowded aisle.
  22. The seat of the Cabin Crew responsible for a suite area must be located to provide a direct view of the egress path from each mini-suite and of each main aisle adjacent to the mini-suites.

### Acronyms and Abbreviations

<b>JAR</b>	Joint Aviation Regulation
<b>EPF</b>	Emergency Passage Feature
<b>TTOL</b>	Taxi, Take-Off and Landing

Disclaimer – This document is not exhaustive and it will be updated gradually.



## D-101: GREEN ARROW AND “OPEN” PLACARD FOR EMERGENCY EXIT MARKING

<b>EQUIVALENT SAFETY FINDING</b>	<b>D-101: Green Arrow and “Open” Placard for Emergency Exit Marking</b>
APPLICABILITY:	A330/A340
REQUIREMENTS:	CS 25.811(e)(4) Amdt 3
ISSUE:	Issue 1 dated 15/02/2018

### Equivalent Safety Finding summary

#### BACKGROUND

CS 25.811(e)(4) states:

“All Type II and larger passenger emergency exits with a locking mechanism released by motion of a handle, must be marked by a red arrow with a shaft at least 19 mm (0.75inches) wide, adjacent to the handle, that indicates the full extent and direction of the unlocking motion required. The word OPEN must be horizontally situated adjacent to the arrowhead and must be in red capital letters at least 25mm (1 inch) high. The arrow and word OPEN must be located on a background, which provides adequate contrast. (See AMC 25.811(e) (4).)”

For A/C fitted with white symbolic exit signs on green background in accordance with EASA CS 25.811 (g) and CS 25.812(b)(1) at Amdt.3, as defined in EASA AMC to CS25.812(b)(1), Airbus believes that the arrow as well as the word “OPEN” required by CS 25.811(e)(4) should be green, in line with the colour code used for the symbolic exit signs.

#### EQUIVALENT SAFETY FINDING

The information displayed on the emergency exits should provide a consistent and coherent message to anyone operation the door in normal and emergency conditions. In that respect, a green arrow and green word “OPEN” on the door are more accurate on aircraft that are equipped with symbolic signs defined in EASA AMC to CS25.812 (b)(1), compared to the red ones. The green colour code used on A330 is standing for “positive” actions (e.g. correct/ready).

In addition, the industry standard SAE ARP 577D documents the improved contrast of green compared to red, thus the green marking meets the intent of the rule by providing a clear and readily visible indication of the full extent and direction of the unlocking handle motion. The green arrow and word “open” installed on the door will provide an accurate contrast to the background of the door linings.

Based on these arguments, Airbus opinion is that a green arrow as well as a green word “OPEN” provide an equivalent level of safety to the requirements of CS25.811(e)(4). The application of the colour changed placards is linked to and can only be installed when symbolic exit signs are selected on the aircraft.

EASA partially agrees to the justification of the equivalence. Following latest rulemaking decision as resulted in CS25 Amnt19, EASA is of the opinion that the colour code of indication markings for

Disclaimer – This document is not exhaustive and it will be updated gradually.



---

opening the exits (the arrow and the word OPEN) should be consistent with the exit indicator signs. Therefore EASA can agree to the following:

The indication markings (arrow and the word OPEN) provide an equivalent level of safety to the requirements of CS 25.811(e)(4) when the aircraft is equipped with symbolic exit signs. The application of the colour changed placards is linked to and can only be installed when symbolic exit signs are selected on the aircraft.

### Acronyms and Abbreviations

<b>JAR</b>	Joint Aviation Regulation
------------	---------------------------

Disclaimer – This document is not exhaustive and it will be updated gradually.



## D-102: INCORPORATION OF INERTIA LOCKING DEVICE IN DYNAMIC SEATS

<b>SPECIAL CONDITION</b>	<b>D-102: Incorporation of Inertia Locking Device in Dynamic Seats</b>
APPLICABILITY:	A330/A340
REQUIREMENTS:	25.562, 25.785
ISSUE:	Issue 1 dated 29/01/2019

### Special Condition summary

#### BACKGROUND

This Special Conditions applies to the incorporation of an inertia locking device (ILD) in some passenger seats on the A330/A340 as a means to achieve compliance with particular aspects of regulation 25.562. In general, seats designed and tested to show compliance have, up until now, relied on either basic seat structure or in some cases, particular ‘passive’ energy absorbing features. The inertia locking device is an ‘active’ seat moving device to help achieve compliance, i.e. a system which mechanically deploys during the impact event. This is considered a novel design feature and one for which a special condition is needed to address requirements applicable to this feature in a seat.

#### SPECIAL CONDITION

##### 1) Level of Protection Provided by Inertia Locking Device(s) (ILD)

The ILD is a mechanically deploying feature of a seat with a fore/aft tracking system. The ILD will self-activate only in the event of a predetermined aircraft loading condition such as that occurring during crash or emergency landing. The ILD will interlock the seat tracking mechanism so as to prevent excessive seat forward translation. EASA considers that a minimum level of protection should be provided if the device does not deploy. It must be demonstrated by test that the seat and attachments, when subject to the emergency landing dynamic conditions specified in 25.562 and with the ILD not deploying, do not suffer structural failure that could result in:

- o separation of the seat from the aircraft floor,
- o separation of any part of the seat that could form a hazard to the seat occupant or any other aircraft occupant,
- o failure of the occupant restraint or any other condition that could result in the occupant separating from the seat. However, failure of the occupant restraint may occur where it can be demonstrated that the seat occupant cannot form a hazard to any other aircraft occupant. This would normally only be agreed by the Agency on the basis of physical separation of the seat from other seats in the aircraft, for example in a mini-suite type arrangement.

Disclaimer – This document is not exhaustive and it will be updated gradually.



## 2) Protection Provided Below and Above the ILD Actuation Condition

The normal means of satisfying the structural and occupant protection requirements of 25.562 result in a non-quantified but nominally predictable progressive structural deformation and/or reduction of injury severity for impact conditions less than the maximum specified by the rule. A seat using the ILD technology however involves a step change in protection for impacts below and above that at which the ILD activates and deploys to its 'retention' position. This could result in the effects of the impact, for example structural deformation and occupant injury criteria, being higher at an intermediate impact condition than that resulting from the maximum.

It is acceptable for these effects to have such non-linear or step change characteristics provided that they do not exceed the allowable maximum at any condition at which the ILD does or does not deploy, up to the maximum severity pulse specified by the requirements. Tests must be performed to demonstrate this taking into account any necessary tolerances for deployment.

## 3) Intermediate Pulse Shape

The existing ideal triangular maximum severity pulse is defined in FAA AC 25.562.1B. EASA considers that for the evaluation and testing of less severe pulses, a similar triangular pulse should be used with acceleration, rise time, and velocity change scaled accordingly.

## 4) Protection over a range of crash pulse vectors

The device will be tested at the regulation 25.562 specified crash pulse vectors of 14g at 30 degrees to the vertical and 16g at the horizontal. In addition it shall be shown that the device will also operate at a range of crash pulse vectors between those specified.

## 5) Protection during Secondary Impacts

The design of the ILD shall be such that if there is more than one impact, for the final impact that is above the severity at which the device is intended to deploy, the maximum protection of the device must be provided.

## 6) Protection of Occupants other than 50th Percentile

The ILD shall not affect compliance of the seat and installation with part 25 requirements, or those of this Special Condition, with respect to protecting the specified range of occupant sizes.

## 7) It must be shown that any inadvertent operation of the device, for example during extreme flight manoeuvres, does not affect the performance of the seat during a subsequent emergency landing.

Disclaimer – This document is not exhaustive and it will be updated gradually.



- 
- 8) The installation of the ILD on the seat shall be physically protected from any contamination likely to occur during operation, e.g. drink, food etc. The installation should also be protected against other foreign object ingress.
  - 9) The effects of wear and criticality of manufacturing tolerances should be considered with respect to reliability and adverse effect on operation of the ILD. In addition other possible effects that may render the device inoperative must be taken into account such as aging/drying of lubricants and corrosion.
  - 10) The design, installation and operation of the ILD shall be such that it is possible, by maintenance action, to check the functioning, i.e. movement, of the device in-situ.
  - 11) A method of functional checking and a maintenance check interval should be established (if applicable).
  - 12) If there is a need to include any means to release an inadvertently operated device (i.e. that has engaged in a non-crash condition where the seat could otherwise remain in-situ on the aircraft), this function shall not introduce additional hidden failures.

### Acronyms and Abbreviations

<b>ILD</b>	Inertia Locking Device
------------	------------------------

Disclaimer – This document is not exhaustive and it will be updated gradually.





## E-2: UNDERFLOOR CREW REST COMPARTMENT

SPECIAL CONDITION	E-2: Underfloor crew rest compartment
APPLICABILITY:	A330 / A340
REQUIREMENTS:	JAR 25.819, 25.812, 25.853, 25.855
ISSUE:	2 dated 05/02/1993

### Special Condition summary

#### BACKGROUND

Airbus Industrie will be offering in option the possibility to install under the cabin floor in the aft cargo hold a crew rest compartment. This crew rest compartment will be enclosed in a removable container, with necessary access to the cabin. It will be occupied by a maximum of 7 crew members and is for in flight use only.

The proposed installation of an underfloor crew compartment is a novel and unusual design feature and the regulation incorporated in the Type Certification Basis do not provide standards for this type of installation. A special condition is therefore necessary to define adequate certification requirements. JAR 25.819 applies to lower deck service compartments occupied during taxi and flight and while not directly related to the issue, will be used as a guideline for the Special Condition.

#### SPECIAL CONDITION

##### Lower Deck Underfloor Crew Rest Compartement

- 1- Occupancy is limited to the number of seats and/or berths installed in the crew rest compartment and is not permitted during taxi, take-off or landing. Smoking is not permitted in the compartment.  
Appropriate placards must be installed to indicate these restrictions.
- 2- There must be a stairway between the cabin floor and the crew rest compartment and there must be an alternate evacuation route for occupants of the crew rest compartment. The hatch of the alternate evacuation route must be openable from the passenger cabin. The stairway and the alternate evacuation route must have sufficient separation within the compartment. They must provide for evacuation of an incapacitated person, with assistance, from the crew rest compartment to the cabin floor, must not be dependent on any powered device, and must be designed to minimize the possibility of blockage which might result from fire, mechanical or structural failure. The procedure for carriage of an uncapacitated person from the crew rest compartment to the cabin floor must be established.
- 3- In the event the aeroplane's main power system should fail, emergency illumination of the crew rest compartment must be automatically provided. Unless two independant sources of normal lighting are provided, the emergency illumination of the crew rest compartment must

Disclaimer – This document is not exhaustive and it will be updated gradually.



be automatically provided if the crew rest compartment normal lighting system should fail. The illumination level must be sufficient for the occupants of the crew rest compartment to locate and climb to the cabin floor by means of the stairway and/or the alternate evacuation route, and to read any required operating instructions.

- 4- There must be means for two-way voice communication between crewmembers in the cockpit and occupants of the crew rest compartment, and at least one cabin attendant seat in the passenger cabin and occupants of the crew rest compartment. The means provided must be useable should the normal electrical power system fail.
- 5- There must also be either public address speaker(s), or other means of alerting the occupants of the crew rest compartment of an emergency situation, installed in the crew rest compartment.
- 6- There must be a means, readily detectable by occupants of the crew rest compartment that indicates when belts should be fastened. In addition, a placard must be installed on each berth, requiring that belts must be fastened when lying down on the berth.
- 7- For each occupant permitted in the crew rest compartment, there must be an approved seat or berth that must be able to withstand the maximum flight loads when occupied.
- 8- The following equipment must be provided in the compartment:
  - a) At least one approved fire extinguisher appropriate to the kinds of fires likely to occur.
  - b) One protective breathing equipment, approved to TSO-C116 or equivalent, suitable for fire-fighting.
  - c) One flashlight
- 9- A smoke detection system that meets the requirements of JAR 25.858 must be provided. It must annunciate in the flight deck and be audible in the crew rest compartment. If waste container(s) is installed, it must meet the requirements of JAR 25.853(e).
- 10- A supplemental oxygen system equivalent to that provided for passengers must be provided for each seat and berth.
- 11- The outside walls of the container in which the crew rest compartment is enclosed including any interface item between the container and the aeroplane structure and systems must meet the applicable requirements of JAR 25.855.
- 12- Means must be provided so that the fire protection level of the cargo hold meets the applicable requirements of JAR 25.855 when the container is not installed.
- 13- Means must be provided to suppress a fire in the crew rest compartment when unoccupied from the passenger cabin without having to enter the compartment. No hazardous quantities of smoke, flames, or extinguishing agents may enter any compartment occupied by the crew

Disclaimer – This document is not exhaustive and it will be updated gradually.



or passengers. The quantity of extinguishing agent shall be adequate for the remaining of the flight.

- 14- There must be an aural warning alerting the occupants of the crew rest compartment of a decompression. It must be activated simultaneously with the corresponding cockpit warning. The warning must sound continuously until a reset button in the crew rest compartment is depressed, unless it can be shown that a time limited warning is adequate.
- 15- If there is low head room at or near the evacuation routes, provisions must be taken to prevent or to absorb head strikes.
- 16- Mattresses used in the crew rest compartment must comply with JAR 25.853(b) and (c).
- 17- It must be shown by actual demonstration that the maximum allowed number of crew rest occupants can easily evacuate the crew rest compartment using the main access route. This demonstration must also be performed using the alternate evacuation route.
- 18- Crew members must be trained in the use of the evacuation routes and in the use of the fire suppression procedures. Fire suppression procedures must be approved.

#### Acronyms and Abbreviations

<b>JAR</b>	Joint Aviation Regulation
<b>TSO</b>	Technical Standard Order

Disclaimer – This document is not exhaustive and it will be updated gradually.



## E-5.1: LOWER DECK LAVATORIES COMPARTMENT

SPECIAL CONDITION	E-5.1: Lower Deck Lavatories Compartment
APPLICABILITY:	A330 / A340, A330-200
REQUIREMENTS:	JAR 25.819, 25.785, 25.812, 25.811, 25.1447, 25.1439, 25.858, 25.853, 25.855 (JAR 25 at change 13), JAR 25.1423 (change 14)
ISSUE:	9 dated 13/11/2003

### Special Condition summary

#### BACKGROUND

The installation of a Lower Deck Lavatory Compartment is a novel and unusual design feature and the regulation incorporated in the Type Certification Basis do not provide adequate standards for this type of installation. A special condition is therefore necessary to define adequate certification requirements and to establish a level of safety equivalent to that established by the airworthiness standards for transport category aeroplanes.

#### SPECIAL CONDITION

##### General Description:

This special condition is applicable to lower deck lavatory compartment with the following typical design characteristics:

Up to 6 lavatories, a stairway from the main deck to the lower deck, a waiting area with or w/o benches, emergency equipment, system installations such as for air-conditioning, communication, smoke detection, oxygen, illumination and all relevant placards and signs.

##### Applicable detailed requirements:

a) There must be appropriate placarding to indicate the maximum allowed number of occupants in the waiting area and on stairs, and to indicate that smoking is not permitted and that occupancy is not permitted during taxi, take-off and landing. If it is not intended that waiting on stairs is to be acceptable there must be appropriate placarding that restricts waiting on stairs. There shall also be a lavatory occupied sign in a conspicuous location visible for passengers waiting at before entering the entrance to the stairway.

Ref. JAR 25.819(f)

b) Reserved.

c) Unless it can be shown that only one escape route provides sufficient performance with respect to the evacuation capability from the lower deck compartment, and sufficient protection against risk

Disclaimer – This document is not exhaustive and it will be updated gradually.



of mechanical blockage, fire induced blockage and structural failure, at least two evacuation routes between the lower deck compartment and the main passenger cabin must be provided.

If there is only one evacuation route, the design of the lower deck lavatory compartment and its access should be such as to minimise the potential fire sources near the escape route. Potential fire sources to be considered include stowage compartments and high power electrical equipment.

It must be demonstrated that the evacuation routes are obvious and usable by naïve passengers.

The evacuation of an incapacitated person (representative of a 95th percentile male), with assistance, from the lower deck to the main passenger cabin floor must be demonstrated. The routes must not be dependent on any powered device. The routes must be designed to minimize the possibility of blockage which might result from fire, mechanical or structural failure, or persons standing on top of or against the escape routes.

There must be a means to prevent passengers from entering the compartment in the event of an emergency, or when the compartment is not to be occupied. If a powered lift system is installed JAR 25.819(g) must be included.

Ref. JAR 25.819(a)

It must be demonstrated that the lower deck lavatory compartment access provisions must allow a flight attendant, equipped for fire fighting, an unrestricted access.

In the case of a fire in the lower deck lavatory compartment, a flight attendant on the main deck shall be able to react to the fire alarm, don the fire fighting equipment, and gain access in a time compatible with the location of and fighting the fire.

The tests or a combination of test and analysis required to demonstrate this capability should be conducted in conditions of smoke and should take into account the movement of passengers up and waiting on the stairs (if waiting on stairs is to be allowed).

d) For any barrier or similar device (e.g. half-height door) installed between the lower deck lavatory compartment and the main passenger compartment, the opening device must be such that it can be opened from both sides without the aid of special tools. When secured in any position, the securing device must sustain the flight loads, and additionally the emergency landing loads in the closed position.

Ref. JAR 25.819(a), JAR 25.561(b)(3)

e) Reserved

f) refer to c)

Disclaimer – This document is not exhaustive and it will be updated gradually.



g) If inflight seating provisions are installed, seat belts must be provided for each seating position. The maximum number of occupants per seat must be placarded.

Appropriate handholds must be provided where people are likely to be in a standing position.

Obstacles and protrusions at or near the evacuation routes must be padded.

Ref. JAR 25.785(c), (j), (k), JAR25.1301

h) Exit signs meeting the requirements of JAR 25.812(b)(1)(i) must be provided in the lower deck compartment. If devices in evacuation routes require particular operating instructions, appropriate placarding should be provided, and should be readable under emergency lighting conditions.

Ref. JAR 25.812(a)(b)

Low level escape routes identification means, supporting escape routes identification, must be provided.

Ref. JAR 25.811(c)

i) In the event of failure of the aircraft's main power system, or of the main passenger compartment lighting system, emergency illumination independent of the main lighting system of the lower deck compartment must be automatically provided. However, the sources of illumination in the lower deck compartment may be common to both, the emergency and the main lighting system if the power supply to the emergency lighting system is independent of the power supply to the main lighting system. The illumination level must be sufficient for the occupants of the lower deck compartment to locate and transfer to the main passenger cabin floor, and to read any required operating instructions.

Ref. JAR 25.812(a)

j) There must be at least one flight attendant call button in an appropriate location in the waiting area.

There must be means for two way voice communication between a cabin attendant in the lower deck area, and crew members in the cockpit and at cabin attendant seating position at each pair of required floor level emergency exit.

k) There must be an aural emergency alarm system, which meets JAR 25.1423, audible during normal and emergency conditions, to enable crew members on the flight deck and at each pair of required floor level emergency exits to alert occupants of each passenger compartment of an emergency situation. Use of a public address system would be acceptable, provided an adequate means to differentiate between normal and emergency communications is incorporated.

Ref. JAR 25.819(c), JAR 25.1423 introduced by change 14

Disclaimer – This document is not exhaustive and it will be updated gradually.



l) Reserved.

m) There must be a means, readily detectible by occupants of the waiting area and on the stairs (if waiting on stairs is to be allowed), that indicates when they should return to their seats and when seat belts should be fastened. In the event there are no seats, at least one sign must be provided.

n) A supplemental oxygen system equivalent to that provided for main deck passengers must be provided for occupants in the waiting area and on the stairs (if waiting on stairs is to be allowed), with the number of oxygen masks equalling the maximum allowed number of occupants, plus 10%. The additional masks shall be distributed taking into account the likely location of the occupants.

Ref. JAR 25.1447

o) At least one each of the following equipment must be provided within the lower deck compartment:

- A Halon fire extinguisher or equivalent as required by JAR 25.851 in addition to those required in the main cabin.
- Protective breathing equipment, approved to TSO-C116 or equivalent and suitable for fire fighting.
- Flashlight
- Approved portable oxygen bottle with 2 masks

The same equipment shall be available on the main deck near the stairway entrance.

Ref. JAR 25.1447(c)(4), JAR 25.1439(a)

p) The waiting area must be equipped with a smoke detector system that meets JAR 25.858(a), provides a visual cockpit warning and a visual and audio warning in each passenger cabin which would be readily detectible by a cabin crew member, taking into consideration the positioning of the cabin crew member throughout the main passenger compartment during various phases of flight. The smoke detection system must be able to detect smoke in areas of the compartment which may be closed off. Additionally unsupervised areas need be considered.

q) If a waste container is fitted in the waiting area, it must meet the requirements of JAR 25.853(e).

Ref. JAR 25.853(e) at change 13

r) Smoking is prohibited in the waiting area. An ashtray must be provided at the entrance to the stairway on the main deck.

s) Materials must comply with JAR 25.853(a) and (c). If seating provisions are installed in the waiting area, they must comply with the requirements for seat cushions.

Ref. JAR 25.853(a), (b) and (c) at change 13

Disclaimer – This document is not exhaustive and it will be updated gradually.



t) Reserved.

u) Any wall of the fixed compartment, forming part of the boundary of the reduced cargo compartment, or facing an open area in the cargo compartment capable of holding cargo, including any interface item between the module (container) and the aeroplane structure or systems must meet the applicable requirements of JAR 25.855.

Ref. JAR 25.855

v) Operational crew members procedures and training must be established for the use of the compartment for normal and emergency procedures. In particular, training should cover the evacuation of an incapacitated person.

### Acronyms and Abbreviations

<b>JAR</b>	Joint Aviation Regulation
<b>TSO</b>	Technical Standard Order

Disclaimer – This document is not exhaustive and it will be updated gradually.





## E-8.1: LOWER DECK STOWAGE AREA

<b>SPECIAL CONDITION</b>	<b>E-8.1: Lower Deck Stowage Area</b> (Installed in combination with a Lower Deck Lavatories Compartment)
APPLICABILITY:	A330 / A340
REQUIREMENTS:	JAR 25.819, 25.853, 25.855, 25.857, 25.858
ISSUE:	4 dated 30/08/2000

### Special Condition summary

## BACKGROUND

The installation of a Lower Deck Stowage area is a novel and unusual design feature and the regulation incorporated in the Type Certification Basis do not provide adequate standards for this type of installation. A special condition is therefore necessary to define adequate certification requirements and to establish a level of safety equivalent to that established by the airworthiness standards for transport category aeroplanes.

## SPECIAL CONDITION

### General

The following design characteristics are typical for the proposed lower deck stowage area concept:

Up to 288 cft compartment volume utilized for stowage of standard galley containers (up to 45 cft) blankets/pillows (up to 9 cft) and crew baggage (up to 35 cft), emergency equipment, system installations such as for air-conditioning, smoke detection, illumination and all relevant placards and signs.

This Special Condition applies in addition to basic requirements applicable to stowage compartments: JAR 25.853, 25.855, 25.857.

### Applicable detailed requirements

a) There must be appropriate placarding to indicate that smoking is not permitted and that occupancy is not permitted during taxi, take-off and landing. There must also be appropriate placarding to indicate that no waiting on the stairway is allowed.

Ref. JAR 25.819(f)

b) Reserved.

c) Unless it can be shown that only one escape route provides sufficient performance with respect to the evacuation capability from the lower deck compartment, and sufficient protection against

Disclaimer – This document is not exhaustive and it will be updated gradually.



risk of mechanical blockage, fire induced blockage and structural failure, at least two evacuation routes between the lower deck compartment and the main passenger cabin must be provided.

If there is only one evacuation route, the design of the lower deck compartment and its access should be such as to minimise the potential fire sources near the escape route. Potential fire sources to be considered include stowage compartments and high power electrical equipment.

It must be demonstrated that the evacuation routes are obvious and usable by naïve passengers

The evacuation of an incapacitated person (representative of a 95th percentile male), with assistance, from the lower deck to the main passenger cabin floor must be demonstrated. The routes must not be dependent on any powered device. The routes must be designed to minimize the possibility of blockage which might result from fire, mechanical or structural failure, or persons standing on top of or against the escape routes.

There must be a means to prevent passengers from entering the compartment in the event of an emergency, or when the compartment is not to be occupied. If a powered lift system is installed, JAR 25.819(g) must be included.

Ref. JAR 25.819(a)

It must be demonstrated that the lower deck stowage compartment access provisions must allow a flight attendant, equipped for fire fighting, an unrestricted access.

In the case of a fire in the lower deck stowage compartment, a flight attendant on the main deck shall be able to react to the fire alarm, don the fire fighting equipment, and gain access in a time compatible with the location of and fighting the fire.

The tests required to demonstrate this capability should be conducted in conditions of smoke and should take into account the movement of passengers up the stairs.

d) For any barrier or similar device (e.g. half-height door) installed between the lower deck compartment and the main passenger compartment, the opening device must be such that it can be opened from both sides without the aid of special tools. When secured in any position the securing device must sustain the flight loads, and additionally the emergency landing loads in the closed position.

Ref. JAR 25.819(a), JAR 25.561(b)(3)

e) There must be a door separating the stowage area from the lower deck compartment allowing for sufficient access by a crew member for fire fighting purposes, as required in (c). The opening device must be such that it can be opened from both sides without the aid of special tools. Means should be provided to avoid unsupervised use of the stowage by passengers.

f) Refer to c)

Disclaimer – This document is not exhaustive and it will be updated gradually.



g) Reserved

h) Exit signs meeting the requirements of JAR 25.812(b)(1)(i) must be provided in the lower deck compartment, but not necessarily in the stowage area itself, due to the limited size. If devices in the evacuation routes require particular operating instructions, appropriate placarding should be provided, and should be readable under emergency lighting conditions.

Ref. JAR 25.812(a), (b)

Low level escape routes identification means, supporting escape routes identification, must be provided.

Ref. JAR 25.811 (c)

i) In the event of failure of the aircraft's main power system, or of the main passenger compartment lighting system, emergency illumination independent of the main lighting system of the lower deck compartment must be automatically provided. However, the sources of general cabin illumination may be common to both, the emergency and the main lighting system if the power supply to the emergency lighting system is independent of the power supply to the main lighting system. The illumination level must be sufficient for the occupants of the lower deck compartment to locate and transfer to the main passenger cabin floor, and to read any required operating instructions.

Ref. JAR 25.812(a)

j) There must be at least one flight attendant call button in an appropriate location in the waiting area. There must be means for two way voice communication between a cabin attendant in the lower deck area, and crew members in the cockpit and at cabin attendant seating position at each pair of required floor level emergency exit.

k) There must be an aural emergency alarm system, which meets JAR 25.1423, audible during normal and emergency conditions, to enable crew members on the flight deck and at each pair of required floor level emergency exits to alert lower deck occupants of an emergency situation.

Use of public address system or crew interphone system would be acceptable, provided an adequate means to differentiate between normal and emergency communications is incorporated.

Ref. JAR 25.819(c), JAR 25.1423 introduced by Change 14

l) Reserved.

m) There must be a means, readily detectable by occupants of the lower deck compartment that indicates when they should return to the main deck. In the event there are no seats, at least one sign must be provided.

Disclaimer – This document is not exhaustive and it will be updated gradually.



n) A supplemental oxygen system equivalent to that provided for main deck passengers must be provided in the lower deck compartment, with the number of oxygen masks equalling at least the maximum allowed number of occupants, plus 10 %. The additional masks shall be distributed taking into account the likely location of the occupants.

Ref. JAR 25.1447

o) At least one each of the following equipment must be provided within the lower deck compartment:

- A Halon fire extinguisher or equivalent as required by JAR 25.851 in addition to those required in the main cabin or other lower deck compartments.
- Protective breathing equipment, approved to TSO-C116 or equivalent and suitable for fire fighting.
- Flashlight
- An approved portable oxygen bottle with 2 masks.

The same equipment shall be available on the main deck near the stairway entrance.

Ref. JAR 25.1447(c)(4), JAR 25.1439(a)

p) The lower deck compartment must be equipped with a smoke detector system that meets JAR 25.858(a), provides a visual cockpit warning and a visual and audio warning in each passenger cabin which would be readily detectible by a cabin crew member, taking into consideration the positioning of the cabin crew member throughout the main passenger compartment during various phases of flight.

The smoke detection system must be able to detect smoke in areas of the compartment which may be closed off like the stowage area. Additionally unsupervised areas need be considered.

q) There should be sufficient access in flight to enable a crew member to reach all parts of the compartment, to extinguish a fire using a hand held fire extinguisher, when standing at any one access point without stepping into the compartment.

If some parts of the stowage area cannot comply with the above mentioned access provisions (e.g. standard galley containers), those portions of the stowage area not directly accessible from the entrance must comply with the fire containment requirements of JAR 25.853 (f) at change 14.

r) Smoking is prohibited in the lower deck compartment.

s) Materials outside of the stowage area must comply with JAR 25.853(a) and (b).

Ref. JAR 25.853 (a), (b) and (c)

t) Reserved.

Disclaimer – This document is not exhaustive and it will be updated gradually.



- 
- u) The lining of the stowage area must be in accordance with JAR 25.855(a)(1)(ii)
  - v) Information regarding the fire fighting techniques applicable to the stowage area must be provided to the airline.
  - w) There must be a means to shut off the ventilation flow, if the stowage area is ventilated.

When the access provisions are being used, no hazardous quantity of smoke, flames or extinguishing agent shall enter any compartment occupied by the crew or passengers.

Ref JAR 25.857(b)(2), JAR 25.855(e)(2).

### Acronyms and Abbreviations

<b>JAR</b>	Joint Aviation Regulation
------------	---------------------------

Disclaimer – This document is not exhaustive and it will be updated gradually.



## E-11: BULK CREW REST COMPARTMENT

<b>SPECIAL CONDITION</b>	<b>E-11: Bulk Crew Rest Compartment</b>
APPLICABILITY:	A330 / A340
REQUIREMENTS:	JAR 25.819, 25.812, 25.853, 25.855
ISSUE:	2 dated 31/02/2002

### Special Condition summary

#### BACKGROUND

Airbus Industrie will be offering in option the possibility to install under the cabin floor in the aft cargo hold a bulk crew rest compartment. This crew rest compartment will be installed in the bulk area with necessary access to the cabin. It will provide for a maximum of 12 crew berth. Alternatively a configuration of up to 8 cabin crew berth plus 2 flight crew berth may be installed in zones separated by a door. The Bulk Crew Rest Compartment (BCRC) is for in flight use only.

The proposed installation of an underfloor crew rest compartment is a novel and unusual design feature and JAR 25 does not provide standards for this type of installation.

A special condition is therefore necessary to define adequate certification requirements.

#### SPECIAL CONDITION

- 1) Occupancy is limited to the number of seats and/or berths installed in the crew rest compartment and is not permitted during taxi, take-off or landing. Smoking is not permitted in the compartment. Appropriate placards must be installed to indicate these restrictions.
- 2) There must be a primary access from the crew rest compartment to the main deck and there must be an alternate evacuation route for occupants of the crew rest compartment. The hatch of the alternate evacuation route must be openable from the passenger cabin. It must also be openable from the crew rest, when a person or fully loaded trolley is standing on the hatch on the main deck.  
The primary and the alternate evacuation route must have sufficient separation within the compartment, and allow for occupants, wherever they may be in the compartment, to have access to both exits by two separate evacuation routes. Both evacuation routes must provide for evacuation of an incapacitated person, with assistance, from the crew rest compartment to the cabin floor, must not be dependent on any powered device, and must be designed to minimize the possibility of blockage which might result from fire, mechanical or structural failure. The procedure for carriage of an incapacitated person from the crew rest compartment to the cabin floor must be established.
- 3) In the event the aeroplane's main power system should fail, emergency illumination of the crew rest compartment must be automatically provided. Unless two independent sources of normal

Disclaimer – This document is not exhaustive and it will be updated gradually.



lighting are provided, the emergency illumination of the crew rest compartment must be automatically provided if the crew rest compartment normal lighting system should fail. The illumination level must be sufficient for the occupants of the crew rest compartment to locate and climb to the cabin floor by means of the ladder and/or the alternate evacuation route, and to read any required operating instructions.

- 4) There must be means for two-way voice communication between crew members in the cockpit and occupants of the crew rest compartment, and at least one cabin attendant seat in the passenger cabin and occupants of the crew rest compartment. The means provided must be useable should the normal electrical power system fail.
- 5) There must also be either public address speaker(s), or other means of alerting the occupants in any part of the crew rest compartment of an emergency situation, installed in the crew rest compartment.
- 6) There must be a means, readily detectable by occupants of the crew rest compartment that indicates when belts should be fastened. In addition, a placard must be installed on each berth, requiring that belts must be fastened when lying down on the berth.
- 7) For each occupant permitted in the crew rest compartment, there must be an approved seat or berth that must be able to withstand the maximum flight loads when occupied.
- 8) The following equipment must be provided in each compartment separated by a door:
  - a) At least one approved fire extinguisher appropriate to the kinds of fires likely to occur.
  - b) One protective breathing equipment approved to TSO-C116a equivalent, suitable for fire fighting.
  - c) One flashlight.
- 9) A smoke detection system (SDS) that meets the requirements of JAR 25.858 must be provided. Alternatively to 25.858(c) automatic tests of the SDS are acceptable. In addition, it must annunciate in the flight deck and be audible in the cabin and in the crew rest compartment. If a waste container(s) is installed, it must meet the requirement of JAR 25.853(f).
- 10) A supplement oxygen system equivalent to that provided for passengers must be provided for each seat and berth.
- 11) The materials inside the BCRC must be in compliance with JAR 25.853(a). Internal Wall and ceiling panel materials have to be in compliance with JAR 25.855(c).
- 12) Means must be provided to suppress a fire in the crew rest compartment when unoccupied from the passenger cabin without having to enter the compartment. No hazardous quantities of smoke, flames or extinguishing agents may enter any compartment occupied by the crew or passengers. The quantity of extinguishing agent shall be adequate for the remaining of the flight.

Disclaimer – This document is not exhaustive and it will be updated gradually.



- 
- 13) There must be an aural warning alerting the occupants of the crew rest compartment of a decompression. It must be activated simultaneously with the corresponding cockpit warning. The warning must sound continuously until a reset button in the crew rest compartment is depressed, unless it can be shown that a time limited warning is adequate.
- 14) If there is low head room at or near the evacuation routes, provisions must be taken to prevent or to absorb head strikes.
- 15) Mattresses used in the crew rest compartment must comply with JAR 25.853(a) and (b).
- 16) It must be shown by actual demonstration that the maximum allowed number of crew rest occupants can easily evacuate the crew rest compartment using the main access route. This demonstration must also be performed using the alternate evacuation route.
- 17) Crew members must be trained in the use of the evacuation routes and in the use of the fire suppression procedures. Fire suppression procedures must be established.
- 18) If rigid doors are installed within the lower crew rest area to separate zones it must be shown that nobody can be trapped inside an isolated compartment. These doors must be openable from either side without the need for a special tool, and must be easily frangible from either side. There should be not more than one door between the isolated zone and the next escape route. There should be not more than one door or hatch between any occupant and the main deck, for at least one of the escape routes.  
Exit signs according JAR 25.811(d)(3) have to be installed on this door.
- 19) Seats or bunks which serve as in-flight seats only have to be equipped with lap belts.

### Acronyms and Abbreviations

<b>BCRC</b>	Bulk Crew Rest Compartment
<b>TSO</b>	Technical Standard Order
<b>JAR</b>	Joint Aviation Regulation
<b>SDS</b>	Smoke Detection System

Disclaimer – This document is not exhaustive and it will be updated gradually.





## E-15: REINFORCED SECURITY COCKPIT DOOR STATUS

Equivalent Safety Finding	E-15: Reinforced Security Cockpit Door Status
APPLICABILITY:	A330 / A340
REQUIREMENTS:	JAR 25.305(b), 307(a), 365, 771, 772, 789(a), 809, 831, 853(a), 1301,1309 JAR 21.21(c)
ISSUE:	3 dated 11/07/2002

### Equivalent Safety Finding summary

#### BACKGROUND

The FAA has introduced new security standards in FAR 25 through amendment 25-106 for new Type Certificates effective on January 15, 2002. This amendment introduces a new paragraph 25.795 which provides standards for resistance of the cockpit door to unauthorized intrusion and small arm fire or fragmentation devices. The FAA is requiring that aeroplanes operating in FAR part 121 service comply with this FAR 25 requirement before April 9, 2003. FAR 25 amendment 25-106 technical standards for resistance to bullet penetration and unauthorized intrusion are based on the work performed by the FAA / JAA "design for security" harmonization working group.

Amendment 27 of ICAO annex 6 is also revised to require that large transport aeroplanes be equipped with a cockpit door designed to resist penetration by small arms fire and grenade shrapnel, and to resist forcible intrusion by unauthorized persons, before 1 November 2003.

The JAA intends to propose a NPA to introduce similar design and operational requirements. In particular, it is expected that the JAA would retain the same or similar technical standards for resistance to bullet penetration and unauthorized intrusion as FAR 25 amendment 106, as such standards are based on the work performed by the FAA / JAA "design for security" harmonization working group.

Airbus has applied for the certification of a reinforced cockpit door designed to meet the requirements of FAR 25 amendment 106.

Compared to the existing Airbus cockpit door design, the proposed modification would include:

- New door materials and strengthening of the door structure and door frame / surrounding structure
- Emergency kick out panel in the door to meet cockpit egress requirements
- Three electro-mechanically actuated door latches controlled by a toggle switch located in the cockpit. The toggle switch can be actuated by both pilots from their seat position. The electrical latches can also be released by the signal of redundant pressure sensors to meet the rapid decompression requirements (decompression case towards the cockpit).
- A manual override unlocking mechanism on the cockpit side
- A code pad in the cabin next to the cockpit door to control requests for access to the cockpit
- Dedicated buzzer and warning system in the cockpit
- A bullet resistant spy hole to monitor cabin access from the cockpit.

Disclaimer – This document is not exhaustive and it will be updated gradually.



As an option, Airbus intends to propose a video camera system to make the forward cabin area visible to the pilots.

The video camera system will be certified independently of the new cockpit doors design, and is not addressed by this Equivalent Safety Finding.

## EQUIVALENT SAFETY FINDING

Revised 25.772 and new 25.795 requirements are acceptable to the JAA as an equivalent safety finding to existing JAR 25.772 paragraph, in accordance with JAR 21.21(c)(2).

The JAA team will check the compliance of the proposed design against the following requirements introduced by FAR 25 amendment 106:

Section 25.772 is amended by revising the introductory language and paragraph (a) and by adding a new paragraph (c) to read as follows:

Sec. 25.772 Pilot compartment doors.

For an aeroplane that has a lockable door installed between the pilot compartment and the passenger compartment:

- (a) For aeroplanes with a maximum passenger seating configuration of more than 20 seats, the emergency exit configuration must be designed so that neither crewmembers nor passengers require use of the flightdeck door in order to reach the emergency exits provided for them; and

\* \* \* \* \*

- (c) There must be an emergency means to enable a flight attendant to enter the pilot compartment in the event that the flightcrew becomes incapacitated.

3. Part 25 is amended by adding a new Sec. 25.795 to read as follows:

Sec. 25.795 Security considerations.

- (a) Protection of flightdeck. If a flightdeck door is required by operating rules, the door installation must be designed to:

- (1) Resist forcible intrusion by unauthorized persons and be capable of withstanding impacts of 300 Joules (221.3 foot-pounds) at the critical locations on the door, as well as a 250 pound (1113 Newtons) constant tensile load on the knob or handle, and
- (2) Resist penetration by small arms fire and fragmentation devices to a level equivalent to level IIIa of the National Institute of Justice Standard (NIJ) 0101.04.

(b) [Reserved]

In order to show that the modified cockpit door can fulfil its intended function in normal and emergency (failure case and hijacking situation) conditions, Airbus should present to the JAA certification team the foreseen minimum sequence of events from which operational procedures associated to this new door design can be developed. Foreseen MMEL relief cases should be presented to the JAA certification team. The JAA requires that the level of safety intended by basic

Disclaimer – This document is not exhaustive and it will be updated gradually.



airworthiness requirements related to rapid decompression and emergency evacuation be maintained under MMEL conditions. In the event of a system failure that would result in a door unlocking, the door should maintain at least the ability to be closed in flight. Airbus should propose operational and or design measures to reduce exposure to the risk of an unauthorized cockpit intrusion in such a case.

Regarding A330 aircraft models, pending availability of a JAA policy, the JAA recommends that the minimum value is used (30s) when considering the emergency unlock function time delay.

Nevertheless, Airbus has indicated that they will include the possibility to program this value between 15s and 120s (with a setting by default at 30s), which could then be modified according to national requirements.

Airbus will inform its operators that the value of the timer present by Airbus is 30s that the recommended setting should be between 30 and 60 seconds, and that operator who would wish a setting below 30 seconds or above 60 seconds should seek the position of their national authority.

In addition, it is proposed to apply the FAA memorandum on Certification of Strengthened Flight Deck Doors on Transport Category Aeroplanes, dated 28 May 2002.

#### Acronyms and Abbreviations

<b>FAA</b>	Federal Aviation Administration
<b>FAR</b>	Federal Aviation Regulations
<b>JAA</b>	Joint Aviation Authorities

Disclaimer – This document is not exhaustive and it will be updated gradually.



## E-17: TROLLEY LIFT

Equivalent Safety Finding	E-17: Trolley Lift
APPLICABILITY:	A330/A340
REQUIREMENTS:	JAR 25.819(g)(2)(3)
ISSUE:	2 dated 13/11/2003

### Equivalent Safety Finding summary

#### BACKGROUND

Airbus offers lower deck facilities on A340 series aircraft as an option. These facilities are located below the main cabin floor, utilizing space which was previously not accessible during flight.

A Lower Deck Galley Compartment is one of the intended utilizations and may be combined with other lower deck passenger or crew facilities, such as lavatory compartments and a crew rest area or stowage area.

To provide adequate transport capability for catering equipment between the main deck and the lower deck galley compartment a trolley lift will be installed. The lift is not designed for transportation of people.

The following design characteristics are typical for the proposed trolley lift design addressed by this Equivalent Safety Finding:

“Two independent trolley lift systems are installed each providing a cage for transportation of e.g. one full size trolley plus two standard container, two half-size trolleys with two containers or container only on ground or during cruise. The transport cage itself as well as the trunk opening on bath decks, are covered each by a door. Sensors on bath doors/latches provide signals to a controller to avoid misuse (e.g. overload, no lift operation with open doors etc.). Operating panels on bath decks above the doors allow a controlled operation of the lift.”

Current applicable requirements include JAR 25.819(g).

JAR 25.819(g)(2)(3);

(g) For each powered lift system installed between a lower deck service compartment and the main deck for the carriage of persons or equipment, or both, the system must meet the following requirements:

- (2) An emergency stop button, that when activated will immediately stop the lift, must be installed within the lift and at each entrance to the lift.
- (3) There must be a hatch capable of being used for evacuating persons from the lift that is openable from inside and outside the lift without tools, with the lift in any position.

The actual design of the trolley lift cage does not provide a stop button inside the lift and does not provide a hatch within the cage.

Disclaimer – This document is not exhaustive and it will be updated gradually.



## EQUIVALENT SAFETY FINDING

The actual design of the trolley lift provides design precautions and safety features as an alternative means to the requirements in 25.819(g)(2)(3), as there are:

- The lift is not designed for transport of persons and is adequately placarded.
- The cage has a limited inner dimension for a single full size trolleys.
- The cage door (inner door) cannot be closed from the inside due to non-availability of grip/handle and air damper that is forcing the door open.
- The trunk door (outer door) cannot be closed if the cage door is not properly closed and latched.
- The lift can only be operated when all doors (inner and outer) are closed and latched.
- On the main deck the operating panel is arranged at a height, which is outside of the accessibility by children.
- At least a second person is necessary (both ignoring all safety features) to trap somebody inside a cage.
- The trolley lift system safety assessment provides data, which a failure causing a lift stop during transit in between both decks is highly improbable.

The above described provisions are sufficient to be satisfied that persons will not travel in the lift. Therefore the provision of a stop button and escape hatch as required by JAR 25.819(g)(2)(3), will provide no additional level of safety. The design is thus considered to be equivalent safe to full and literal compliance to these requirements.

## Acronyms and Abbreviations

<b>ESF</b>	Equivalent Safety Finding
<b>JAR</b>	Joint Aviation Regulation

Disclaimer – This document is not exhaustive and it will be updated gradually.



## E-18: LOWER DECK GALLEY COMPARTMENT

Equivalent Safety Finding	E-18: Lower Deck Galley Compartment
APPLICABILITY:	A330 / A340/A340-500/-600
REQUIREMENTS:	JAR 25.819(f)
ISSUE:	2 dated 13/11/2003

### Equivalent Safety Finding summary

#### BACKGROUND

Airbus offers lower deck facilities on A330 / A340 series including A340-500/-600 aircraft as an option. These facilities are located below the main cabin floor, utilizing space which was previously not accessible during flight.

A Lower Deck Galley Compartment is one of the intended utilizations and may be combined with other lower deck passenger or crew facilities, such as lavatory compartments and a crew rest area or stowage area.

The following design characteristics are typical for the proposed lower deck galley compartment addressed by this Equivalent Safety Finding:

- Located next to a lavatory area accessible by passengers via a stairway, the galley is within an access restricted area separated by a door. Typical installations are two longitudinal galleys, a trolley lift, stowage areas and access to an optional associated Dock on Crew Rest (DCR). An escape hatch in the galley area provides an additional escape route to the main deck. System installations such as air-conditioning, communication from/to the main deck, smoke detection, oxygen, illumination and all relevant placards and signs are installed to support the working area as well as the single Cabin Attendant Seat (CAS) justified for flight loads (25.785(d)).

The proposed installation of a Lower Deck Galley Compartment is reflected in JAR 25.819.

*25.819(f) states:*

*(f) For each occupant permitted in a lower deck service compartment, there must be a forward or aft facing seat, which meets the requirements of JAR 25.785 (d) and must be able to withstand maximum flight loads when occupied.*

The galley compartment will not be limited to be used by one Cabin Attendant (CA) only. Due to the installation of one single CAS literal compliance is not achieved.

#### EQUIVALENT SAFETY FINDING

The design of the lower deck galleys with a single CAS provides an acceptable alternative means due to following aspects:

Disclaimer – This document is not exhaustive and it will be updated gradually.



- Galley area is only accessible to authorized cabin crew.
- Cabin crew is trained for this environment.
- Distance to the next available CAS on the main deck is comparatively shorter than distances on the main deck.
- Accessibility from the lower deck galley area to the next CAS on the main deck is comparatively better and does not rely on system function (lift system) as in former design solutions. This includes that several CA can reach the main deck nearly simultaneously by using the stair and do not have to wait for a lift system requiring various transits.

To maintain a same level of safety to that found on the main deck (i.e. the likely distances that cabin crew would need to move from their work areas to a seat), the following additional requirements should be met:

- Each of these seats must be a forward or aft facing seat, which meets the requirements of JAR 25.785(d).
- The number of cabin crew permitted to occupy the lower deck galley must not exceed the number of seats in the galley plus those located for crew use close to the top of the staircase.
- The maximum number of cabin crew permitted to occupy the lower deck galley must be adequately placarded in the galley area.
- There must be adequate placard in the galley to inform the cabin crew that seats are available on the main deck and to indicate the location of these seats.
- The operator must be informed that operational procedures need to be developed to ensure that:
  1. CA's working in the galley are aware that their assigned seats are those close to the top of the stairs (or the single seat in the galley)
  2. These seats will be available to them when needed.

### Acronyms and Abbreviations

<b>CA</b>	Cabin Attendant
<b>CAS</b>	Cabin Attendant Seat
<b>DCR</b>	Dock on Crew Rest
<b>JAR</b>	Joint Aviation Regulation

Disclaimer – This document is not exhaustive and it will be updated gradually.





## E-19: FIRST CLASS SLIDING SCREENS

<b>SPECIAL CONDITION</b>	<b>E-19: First Class Sliding Screens</b>
APPLICABILITY:	A330 / A340
REQUIREMENTS:	JAR 25.785(h)(2), 25.813(e)
ISSUE:	4, dated 22/06/2009

### Special Condition summary

#### BACKGROUND

The Special Condition (SC) E-19 was issued to determine the regulatory context for so called “mini-suites” in dedicated customized First Class Cabin design. After its closure SC E-19 was reopened to introduce adapted level of requirements after application of further customized designs.

The special conditions from SC E-19 should be seen as guideline. For any new implementation of mini-suites the respective airworthiness authority shall be contacted.

#### SPECIAL CONDITION

SC E-19 was closed at issue 02, on 15 September 2003 with the following conclusion:

First Class mini-suites are acceptable as complying with the intent of JAR 25.813 (e) provided the following Special Condition is met:

- a) Robust design and/or procedural safeguards must be developed to assure that the doors will be secured open during taxi, take-off and landing. When the doors are in the open position, each must have a means to securely latch it in this position and the means must be able to withstand the loads imposed upon it when the door is subjected to the inertia forces listed in JAR 25.561 (b).
- b) It must be demonstrated that the normal door actuation system is sufficiently reliable that inadvertent closing during the critical flight phases is precluded.
- c) There must be a means by which cabin crew can readily check that all mini-suite doors are in the fully open and latched condition. There must be means by which cabin crew can prevent the seated mini-suite occupant from operating the doors.
- d) Opening of the doors, by someone inside or outside a mini-suite, in the event of electrical power loss or system failure, must be demonstrated to be instinctive and require no excessive strength or manual dexterity. This demonstration must cover the range of passenger size from 5th percentile female to 95th percentile male, and the fact that in the event of electrical power loss the cabin may be in emergency lighting conditions.

Disclaimer – This document is not exhaustive and it will be updated gradually.





- e) The height of the doors and adjacent "furniture" above the cabin floor in the aisles must be such that each passenger's actions and demeanor can be readily observed by cabin crew members with stature as low as the 5th percentile female.

SC E-19 was reopened at issue 3 for extension and finally closed at issue 4 on 22 June 2009 with the following conclusion:

Mini-Suites on A330/A340 will be accepted as complying with the intent of JAR 25.785(h)(2) and JAR25.813 (e), provided the following Special Conditions are met:

1. Only single occupancy of the Mini-suite is allowed during taxi, take-off and landing
2. Mini-suite entrance can only provide access to the specific mini-suite
3. Mini-suites cannot provide an egress path for evacuation other than the path out of the mini-suite for its single occupant
4. Installation of the mini-suites must not introduce any additional obstructions or diversions to evacuating passengers, even from other parts of the cabin
5. The design of the doors and surrounding "furniture" above the cabin floor in the aisles must be such that each passenger's actions and demeanour can be readily observed by cabin crew members with stature as low as the 5<sup>th</sup> percentile female, when walking along the aisle.
6. The mini-suite doors must be open during taxi, take off and landing
7. The hold open retention mechanism for mini-suite doors must hold the doors open under JAR 25.561(b) emergency landing conditions
8. There must be a secondary, backup hold open retention mechanism for the mini-suite doors that can be used to "lock" the doors in the open position if there is an electrical or mechanical failure of the primary retention mechanism. The secondary retention mechanism must hold the doors open under JAR 25.561(b) emergency landing conditions
9. There must be a means by which cabin crew can readily check, that all mini-suite doors are in the fully open and in the latched condition.
10. There must be means by which cabin crew can prevent the seated mini-suite occupant from operating the doors. This means is envisaged to be used in particular to secure the TTOL phases of the flight.
11. Appropriate placards, or other equivalent means must be provided to ensure the mini-suite occupants know that the doors must be in the open position for taxi, take off and landing
12. Training and operating instruction materials regarding the proper configuration of the mini-suite doors for taxi, take off and landing must be provided to the operator for incorporation into their cabin crew training programs and associated operational manuals.
13. The mini-suite must have an Emergency Passage Feature (EPF) to allow for evacuation of the mini-suite occupant in the event the door closes and becomes jammed during an emergency landing. This EPF may be through frangibility and /or a removable of emergency panel, or equivalent (such as dual sliding doors). The EPF must be easily broken /removed by the occupant of the mini-suite when the door becomes jammed. Trapping of any occupant is not acceptable and in no case shall the occupant using the EPF have to rely on another occupant to assist in passage. The EPF design must be such that any occupant's egress route to the aisle cannot present (after manipulation of frangible/removable/movable items, if applicable) an

Disclaimer – This document is not exhaustive and it will be updated gradually.



aperture of less than 15 inches wide following any possible failure/malfunction occurring during an emergency landing. It must be demonstrated that any frangible/removable/movable items can be easily manipulated. The occupant of the mini-suite must be made aware of the EPF and its way of operation.

14. The height of the mini suite walls and doors must be such that a 95<sup>th</sup> percentile male can fit between them and the aeroplane interior furnishing.
15. No mechanism to latch the doors together in the closed position is allowed
16. The mini-suite doors must be openable from the inside or outside with 25 pounds force or less regardless of power failure conditions
17. If the mini-suite doors are electrically powered the doors must remained “locked” in the open position after power loss to the mini-suite
18. Mini-suites installation must maintain the main, cross aisles and passage ways
19. Mini-suite doors must not impede main aisle or cross aisle egress paths in the open, closed or translating position
20. The mini-suite doors must be openable even with a crowded aisle
21. The number of individual passenger seat modules shall not exceed 25% of the max. number of passenger seats allowed between the doors as defined in the seat frame specification.
22. The length of each main aisle adjacent to the seat modules must be visible, at least such that the main aisle part remaining unobservable does not exceed 50% of the total main aisle width at the end of this cabin section (entrance area of last seat module)
23. In case the main aisle width cannot be observed to at least 50% at the end of the cabin section (entrance area of last seat module), it is equivalent to have at least 80% of the seat module entrance areas in direct view from designated direct view seats, under the conditions of CRI E-4. An entrance area is considered visible, if a person standing in the main aisle, directly at the seat module entrance is observable. In line with the current assist space dimension a body depth of 12 inches is therefore assumed.

Note: Compliance with 25.785(h)(2) can be demonstrated either by meeting special conditions 22 and 23 as listed above or by complying with Special Condition E-4.

### Acronyms and Abbreviations

<b>SC</b>	Special Condition
<b>JAR</b>	Joint Aviation Regulation

Disclaimer – This document is not exhaustive and it will be updated gradually.



## E-21: EMERGENCY EXIT MARKING REFLECTANCE

Equivalent Safety Finding	E-21: Emergency exit marking reflectance
APPLICABILITY:	A330 / A340
REQUIREMENTS:	JAR 25.811(f)
ISSUE:	1 dated 06/12/2004

### Equivalent Safety Finding summary

#### BACKGROUND

Following JAR 25.811(f), each emergency exit that is required to be openable from the outside, and its means of opening, must be marked on the outside of the aeroplane. In addition, the following apply:

1. The outside marking for each passenger emergency exit in the side of the fuselage must include a 2-inch coloured band outlining the exit.
2. Each outside marking including the band must have colour contrast to be readily distinguishable from the surrounding fuselage surface. The contrast must be such that if the reflectance of the darker colour is 15% or less, the reflectance of the lighter colour must be at least 45%. "Reflectance" is the ratio of the luminous flux reflected by a body to the luminous flux it receives. When the reflectance of the darker colour is greater than 15%, at least a 30% difference between its reflectance and the reflectance of the lighter colour must be provided.

#### EQUIVALENT SAFETY FINDING

In some rare cases amongst the numerous associations of two contrasted colours, Airbus may face a non-compliance with the required reflectance value imposed by the JAR 25.811(f). For a specific case, the black colour is at 0.5% (thus less than the 15% threshold condition which requires the 45% value for the contrasted colour) and that the grey colour at 38.2% only for the reflectance, the association of both these colours does not meet the §25.811(f) requirements.

Considering the design of the handle and its operation is simple and obvious as well as the movement required to open the door is indicated by an arrow clearly identifiable. The door surrounding band contrast is well above the requirement of 25.811(f). The reflectance of the grey colour is at 38.2% which is below the required value of 45%. However, it is accepted that the outside marking have a colour contrast which is readily distinguishable from the surrounding fuselage surface.

#### Acronyms and Abbreviations

<b>ESF</b>	Equivalent Safety Finding
<b>JAR</b>	Joint Aviation Regulation

Disclaimer – This document is not exhaustive and it will be updated gradually.



**E-27: FORWARD FACING SEAT, OVER 18 DEGREES TO A/C CENTRELINE**

<b>EQUIVALENT SAFETY FINDING</b>	<b>E-27: FORWARD FACING SEAT, OVER 18 DEGREES TO A/C CENTRELINE</b>
APPLICABILITY:	A330/A340
REQUIREMENTS:	JAR 25.785 (d)
ISSUE:	Issue 3 dated 22 June 2009

**Equivalent Safety Finding summary**

**BACKGROUND**

JAR 25.785(d) requires that:

“each occupant of a seat that makes more than 18 degrees angle with the vertical plane containing the aeroplane centreline must be protected from head injury by a safety belt and an energy absorbing rest that will support the arms, shoulders, head and spine, or by a safety belt and shoulder harness that will prevent the head from contacting any injurious object”.

Airbus is installing seats up to 23.5 degrees that including inflatable restraint systems (airbags) to manage occupant trajectory, but do not include any feature or features that can be construed to constitute an energy absorbing rest or a shoulder harness.

**EQUIVALENT SAFETY FINDING**

It may be possible to design a seat for installation at an angle above the value of 18 degrees set in JAR 25.785(d), with an acceptable level of occupant safety, without providing an energy absorbing rest or shoulder harness.

The designs of the seat and surrounding items have been carefully chosen to maximize the ability of the occupant to align with the deceleration vector during the impact. EASA is prepared to accept this as a compensating factor as required by 21A.21.

It appears that the occupant does not realign as much as was originally expected and that in fact the design of the airbag plays a significant role in maintaining acceptable protection.

Furthermore, ATD internal force and moment measurements, in addition to those required by JAR 25.562(c), are necessary for comparative purposes. These can be taken during dynamic testing and compared with values from tests of a seat installed at less than 18 degrees to the aircraft centreline. It should be noted that this approach cannot at present involve consideration of absolute values as research data do not exist to back this up. Rather, this will involve a check that the values observed are of comparable magnitude and range and will provide additional confidence that the mitigating factors are achieving the desired outcome.

Disclaimer – This document is not exhaustive and it will be updated gradually.



---

EASA agrees that an equivalent level of safety to JAR 25.785(d) can be shown by the approach outlined above.

### Acronyms and Abbreviations

<b>JAR</b>	Joint Aviation Regulation
<b>ACJ</b>	Advisory Circular Joint
<b>ATD</b>	Aircraft Technical Description
<b>DEV</b>	Deviation
<b>ESF</b>	Equivalent Safety Finding
<b>SC</b>	Special Condition
<b>TCDS</b>	Type Certificate Data Sheet

Disclaimer – This document is not exhaustive and it will be updated gradually.



## **E-28: PARTIAL BULK CREW REST COMPARTMENT WITH ATTACHED GALLEY**

<b>SPECIAL CONDITION</b>	<b>E-28: PARTIAL BULK CREW REST COMPARTMENT WITH ATTACHED GALLEY</b>
APPLICABILITY:	A330 / A340
REQUIREMENTS:	JAR 25.819, 25.812, 25.853, 25.855
ISSUE:	Issue 2 dated 26 Jan 2009

### **Special Condition summary**

#### **BACKGROUND**

Airbus intend to install a galley stowage area in the bulk crew rest compartment. Due to the fact that the galley area will be handled in a different operational form from that of a pilot sleeping area, new special conditions is proposed.

#### **SPECIAL CONDITION**

All references to JAR 25 paragraphs are to be understood as references to JAR change 14 plus OP 96/1.

The following special conditions are applicable in the case where a galley stowage are is installed adjacent to a partial bulk crew rest.

- 1) CRI SE-11 remains applicale to all areas of the BCRC unaffected by the addition of the galley stowage area.
- 2) JAR 25.819 (a) and (f) need not be complied with for the subject galley stowage area.
- 3) Temporary occupancy is limited to two persons in the galley area. This is in excess of the number allowed in the crew rest sleeping area. Access is prohibited during taxi, take-off and landing appropriate placars must be installed.
- 4) Due to the non-permanent occupied character of the galley area, a single access to/from the partial bulk crew rest compartment entrance area is sufficient. This access must only be closed off by a curtain, which must be such that easy entrance / egress is assured, even when closed.
- 5) In the event the aeroplane's main power system should fail, emergency illumination of the galley area must be automatically provided.
- 6) There must be public address speaker(s), or other means of alerting the occupants of an emergency situation, in the galley area.
- 7) A smoke detection and fire suppression system must be provided that is fully effective in both the crew rest ans in the galley area. Its effectiveness must not be reduced by any separation provided between the partial BCRC and the galley area.
- 8) A epplumentary oxygen system with at least two masks, equivalent to that provided for passengers, must be provided in the galley area.
- 9) The materials inside the galley area of the BCRC must be in compliance with JAR 25.853(a) internal wall and ceiling panel materials as well as the outer walls forming a wall to the remaining cargo compartment must be in compliance with JAR 25.855(c).

Disclaimer – This document is not exhaustive and it will be updated gradually.



- 
- 10) An exit sign according to JAR 25.811(d)(3) must be appropriately installed in the galley area. However, a sign with reduced background area of no less than 5.3 square inches (excluding the letters) may be utilized, provided that it is installed such that the material surrounding the exit sign is light in color (e.g. white, cream, light beige).
- 11) Means must be provided to prevent opening of the cargo service door into the class C cargo compartment, from the galley stowage area, once it has been closed. Placards must also be provided on both sides of the cargo service door requiring that the cargo service door be closed before all aeroplane flight operations.

### Acronyms and Abbreviations

<b>JAR</b>	Joint Aviation Regulation
<b>BCRC</b>	bulk crew rest compartment

Disclaimer – This document is not exhaustive and it will be updated gradually.





## E-29: FUSELAGE BURN THROUGH – AFT PRESSURE BULKHEAD

<b>EQUIVALENT SAFETY FINDING</b>	<b>E-29: FUSELAGE BURN THROUGH – AFT PRESSURE BULKHEAD</b>
APPLICABILITY:	A330/A340
REQUIREMENTS:	JAR 25.853(b) at change 13 JAR 25.853(a) at change 14 JAR 25.855(d) at change 14 FAR 25.856(a) at amendment 111 (ESF E-1022) FAR 25.856(b) at amendment 111 (SC E-128)
ISSUE:	Issue 3 dated 16 March 2009

### Equivalent Safety Finding summary

#### BACKGROUND

In order to improve the overall aircraft flammability standard, Airbus voluntarily elected to comply with FAR 25.856(b) rule, through SC E-128. Airbus A330/A340 design incorporates a carbon Fiber aft pressure bulkhead. The insulation on the aft pressure bulkhead does not comply with the requirements of SC E-128 (FAR 25.856(b)), however, the bulkhead itself does. Airbus proposes an alternative method under the provisions of Part 21A.16B.

#### EQUIVALENT SAFETY FINDING

In order to improve the overall aircraft flammability standard, Airbus voluntarily elects to comply with FAR 25.856(b) rule, through SC E-128. This requires, for aircraft with a passenger capacity of 20 or greater, thermal/acoustic insulation materials (including the means of fastening the materials to the fuselage) installed in the lower half of the aircraft fuselage to meet the flame penetration resistance test requirements according to FAR Part 25.856(b), appendix F part VII. The intent of the rule is to provide a fire barrier that will delay entry of post-crash fire into the passenger occupied areas of the aircraft. If an aircraft were to incorporate insulation not on the fuselage shell, but along the underside of the cargo floor, this insulation would be subject to the flame penetration test of final FAR Part 25.856(b).

For pressure bulkheads made from composite parts, the bulkheads will be covered with thermal/acoustic insulation materials that meet FAR 25.856(a) requirements. The present ELOS demonstrates that the existing pressure bulkhead, designed with composite material are flame penetration resistant. As a consequence, the upgrade of the insulation materials inboard of the pressure bulkhead, according to the flammability standard of FAR 25.856(b), will not improve the overall flame penetration protection of the current installation.

According to Part 21A.16B, alternate standards and design features that can meet the objective of the requirement can be used. Using the composite material of the pressure bulkhead is an alternative

Disclaimer – This document is not exhaustive and it will be updated gradually.





method to meet the intent of FAR 25.856(b) (SC E-128). Composite parts provide post-crash fire protection that is as good as the protection provided by FAR 25.856(b) compliant insulation materials. So, the composite pressure bulkhead is an alternate design feature to FAR 25.856(b) insulation materials to demonstrate an equivalent level of safety with respect to post-crash fires. With this approach, Airbus takes benefit of existing composite pressure bulk-head design and does not intend to extend or generalize it to new composite applications or designs. In the approach used in this demonstration, the premises under which the rule has been developed remain valid.

The composite pressure bulkhead is a full part, so that it provides a surface of protection above and below the split line (see figure), while the rule requires a fire barrier below the split line. The protection provided in terms of crash fire protection is therefore locally increased compared to the requirements of FAR 25.856(b).

It is also clear that the composite pressure bulkheads that are fitted on existing Airbus designs will stay in the aeroplane. This is a reason why Airbus is taking credit of their fire properties in lieu of the insulation materials. Where FAR 25.856(b) applies – the modification of insulation materials and fixation installed on the existing composite pressure bulkhead will not bring an improved fire penetration protection:

- The modification of the insulation and fixation on existing composite parts will not decrease the delay for a fire to penetrate into the passenger compartment, in terms of FAR 25.856(b).
- On existing Airbus aeroplanes, the composite parts are remotely used to demonstrate compliance with FAR 25.856(b), as only few of them are installed with insulation materials that are subject to the requirements of FAR 25.856(b).

The pressure bulkhead made of CFRP, min thickness 3mm, is burn through resistant according to FAR 25.856(b). Therefore it overtakes the function of a Thermal/Acoustic Burnthrough resistance fire barrier.

Tests performed according to 25.856(b) and Appendix F Part VII:

- A 3-ply/side CFRP Sandwich floor Panel,
- A 3 mm CFRP pressure bulkhead Panel and

Tests performed according to AC20-107A:

- A 1.75 mm CFRP Flap Panel

These tests demonstrate the burn through resistance of in minimum 3 layers CFRP with a min thickness of 0.32 mm/layer.

The results show that this material is a Fire Barrier, with equivalent performances in terms of FAR25.856 (b) protection, compared to the insulation materials.

Based on that analysis, it is demonstrated that the composite materials used for the pressure bulkhead behave as a fire barrier, in terms of FAR 25.856(b) in combination with a thermal/acoustic insulation

Disclaimer – This document is not exhaustive and it will be updated gradually.



blanket. No additional means or modification for burn through is therefore required on the insulation materials that are installed on the pressure bulkhead.

The scope of the ESF is limited to the composite pressure bulkhead, which is continuous and protects the upper half in addition to the lower half of the fuselage. For clarification, the rule requires the flammability standard upgrade according to FAR 25.856(b) of thermal/acoustic insulation materials that are installed in the lower half fuselage. The continuity is therefore provided between the pressure bulkhead and FAR 25.856(a) insulation materials in the upper fuselage and with FAR 25.856(b) insulation materials in the lower fuselage. AIRBUS considers that EASA request to have continuity between the FAR 25.856(b) composite pressure bulkhead and the FAR 25.856(b) insulation materials exceed the scope of this ESF. However, it is provided in the lower half of the fuselage according to AIRBUS design principles for compliance with FAR 25.856(b).

EASA agrees to the above Airbus position. This ESF is limited to the composite pressure bulkhead to provide equivalent burnthrough resistance as FAR 25.856(b) compliant insulation material.

The continuity of the burnthrough resistant barrier will be part of the overall compliance demonstration of Airbus regarding FAR 25.856(b).

### Acronyms and Abbreviations

<b>JAR</b>	Joint Aviation Regulation
<b>CFRP</b>	Carbon Fiber Reinforced Regulations
<b>DEV</b>	Deviation
<b>ELOS</b>	Equivalent Level of Safety
<b>ESF</b>	Equivalent Safety Finding
<b>OP</b>	Orange Paper
<b>SC</b>	Special Condition
<b>TCDS</b>	Type Certificate Data Sheet

Disclaimer – This document is not exhaustive and it will be updated gradually.



## E-30: FUSELAGE BURNTHROUGH SUBSTANTIATION FOR BELLY FAIRING

<b>EQUIVALENT SAFETY FINDING</b>	<b>E-30: FUSELAGE BURNTHROUGH SUBSTANTIATION FOR BELLY FAIRING</b>
APPLICABILITY:	A330/A340
REQUIREMENTS:	JAR 25.853(b) at change 13 JAR 25.853(a) at change 14 JAR 25.855(d) at change 14 FAR 25.856(a) at amendment 111 (ESF E-1022) FAR 25.856(b) at amendment 111 (AMC E-128)
ISSUE:	Issue 3 dated 20 April 2009

### Equivalent Safety Finding summary

#### BACKGROUND

In order to improve the overall aircraft flammability standard, Airbus voluntarily elects to comply with FAR 25.856(b) rule, through the AMC E-128. This requires, for aircraft with a passenger capacity of 20 or greater, thermal/acoustic insulation materials (including the means of fastening the materials to the fuselage) installed in the lower half of the aircraft fuselage to meet the flame penetration resistance test requirements according to FAR Part 25.856(b), appendix F part VII.

The Belly Fairing covers the lower half of the fuselage in its lower part. Per design, the Belly Fairing on Long Range is a composite part, which is post-crash fire resistant in terms of FAR 25.856(b). Consequently, the Belly Fairing can be used as an alternative method to meet the intent of FAR 25.856(b), and thus the modification according to FAR 25.856(b) of existing insulation materials inboard of the lowest part of the fuselage, could be avoided. Thus, Airbus proposes an alternative method under the equivalent level of safety provisions of Part 21A16B.

The scope of the present ESF for A330 is limited to the protection of the frame 53.2. The other areas of the lower fuselage that are covered by the Belly Fairing will have modified insulation materials in the fuselage in accordance with FAR 25.856(b).

For A330/A340 aircraft models, Airbus drew up an analysis based on tests performed on the worst-case composite Belly Fairing design (thinner composite panel used on existing design, junction between panels and access panels).

The tests performed according to FAR 25.856(b) and Appendix F Part VII and AC20-107A have demonstrated that the material, as well as the junction between the panels were acting as a fire barrier - no burn through occurred - with flame penetration performance comparable to the one obtained with FAR 25.856(b) insulation materials.

The tests also revealed some weakness at the access door latches. However, the area considered for the A330/A340 is limited to Frame 53.2, which does not include access panels (i.e. no modification of the access panels are needed to meet the intent of the present ESF).

Disclaimer – This document is not exhaustive and it will be updated gradually.



In order to ensure a continuity of the fire protection at the Belly Fairing contour, Airbus determined by test an overlap area between the FAR 25.856(b) compliant insulation materials and the Belly Fairing contour. This overlap will ensure a continuous flame penetration protection through rough the lower half of the fuselage.

The composite Belly Fairing is installed as a standard part on existing Airbus A330/A340 aircraft models. Therefore, Airbus wants to take credit of the fire properties instead of modifying the insulation materials. The modification of insulation materials in the fuselage underneath the Belly Fairing at Frame 53.2 will not increase the delay for a fire to penetrate into the passenger compartment, with respect to FAR 25.856(b) requirements. In addition, the Belly Fairing improves the flame penetration resistance in areas that are per design not insulated, and which per rule do not need to be modified according to FAR 25.856(b).

## EQUIVALENT SAFETY FINDING

Based on the above mentioned tests performed by Airbus, for Frame 53.2 only, the composite Belly Fairing installed on Airbus A330/A340 aircraft models provides an equivalent fire barrier to that requested by FAR 25.856(b).

## Acronyms and Abbreviations

<b>JAR</b>	Joint Aviation Regulation
<b>ESF</b>	Equivalent Safety Finding
<b>FAR</b>	Federal Aviation Regulation

Disclaimer – This document is not exhaustive and it will be updated gradually.



## E-31: FUSELAGE BURNTHROUGH SUBSTANTIATION FOR BILGE AREA

EQUIVALENT SAFETY FINDING	E-30: FUSELAGE BURNTHROUGH SUBSTANTIATION FOR BILGE AREA
APPLICABILITY:	A330/A340
REQUIREMENTS:	JAR 25.853(b) at change 13 JAR 25.853(a) at change 14 JAR 25.855(d) at change 14 FAR 25.856(a) at amendment 111 (ESF E-1022) FAR 25.856(b) at amendment 111 (AMC E-128)
ISSUE:	Issue 3 dated 20 April 2009

### Equivalent Safety Finding summary

#### BACKGROUND

A330/A340 aircraft models Design typically do not have thermal/acoustic insulation installed on the fuselage skin in the bilge areas (the area below the lower lobe cargo floor). Instead, most Airbus aeroplanes have the insulation installed on the underside of the cargo floor, and per the flame penetration requirements of FAR 25.856(b), this insulation would be subject to the fire penetration resistance test of appendix F, part VII. Since implementing this level of fire protection into the insulation on the floor panels presents several design and implementation challenges, Airbus has proposed an alternative method of compliance under the provisions of Part 21A16B.

#### EQUIVALENT SAFETY FINDING

The existing cargo floor panels have been tested and the results showed that the layers are flame penetration resistant in terms of FAR 25.586 (b). The floor panels constitute a fire barrier (Barrier 1), with a determined amount of openings (drain pans, Power Drive Units, etc.).

The cargo compartment lining is qualified and certified according to 25.855(c), appendix F part III, and constitutes also a fire barrier (Barrier 2).

With respect to the burn through resistance of LDCC floor, the barrier 1 acts as a "filter". Airbus has demonstrated that the remaining heat flux that passes through it dissipates in the LDCC (forward and aft sections). The amount of heat flux to which the cargo lining and cargo ceiling (Barrier 2) are exposed reduces extremely significantly. The analysis performed shows that the heat flux to which the cargo ceiling (Barrier 2) can be exposed is below the maximum heat flux value mandated by the rule Furthermore, tests performed by Airbus have demonstrated that the temperature at the level of the cargo ceiling (Barrier 2) never exceeds 1700°F (927°C) within 4 minutes.

Airbus has demonstrated that the LDCC constitutes an effective burn through barrier. The combination of Barrier 1 according to FAR Part 25.856 (b) and of the Barrier 2 according to FAR

Disclaimer – This document is not exhaustive and it will be updated gradually.



Part 25.855 (c) increases the time for evacuation in case of a post-crash fire sufficiently to meet the intent of the requirements of FAR 25.856 (b).

Based on the LDCC demonstration, similar analysis has been conducted for all the different Lower Deck Compartments, and demonstrates that these compartments provide an effective flame penetration protection. This analysis takes into account the specificities of each Airbus design and covers the different type of existing Crew Rest Compartments/Lower Deck Facilities: Mobile Crew Rest Compartment Aft, Bulk Crew rest Compartment Aft, Lower Deck Facilities Aft and Forward on A330 aircraft models.

In view of the above considerations and related test evidences, the LDCC on Airbus Long Range Aeroplanes are considered compliant with FAR part 25.856(b) through the here described equivalent level of safety approach.

### Acronyms and Abbreviations

<b>JAR</b>	Joint Aviation Regulation
<b>ESF</b>	Equivalent Safety Finding
<b>FAR</b>	Federal Aviation Regulation
<b>LDCC</b>	Lower Deck Crew Compartment

Disclaimer – This document is not exhaustive and it will be updated gradually.



**E-128: IMPROVED FLAMMABILITY STANDARD FOR THERMAL/ACOUSTIC INSULATION MATERIALS – FLAME PENETRATION (EQUIVALENT TO FAR 25.856(B) AT AMENDMENT 111)**

<b>SPECIAL CONDITION</b>	<b>E-128: Improved flammability standard for thermal/acoustic insulation materials – Flame penetration (equivalent to FAR 25.856(b) at amendment 111)</b>
APPLICABILITY:	A330/A340/A340-500/A340-600
REQUIREMENTS:	Part 21A.16B, JAR 25.853, JAR 25.855, Post TC CRI E-1022 – Improved flammability standards for Thermal/acoustic insulation – Flame propagation (equivalent to FAR 25.856(a) at amendment 111)
ISSUE:	2 dated 03/02/2009

**Special Condition summary**

**BACKGROUND**

Current European flammability standards for thermal/acoustic insulation do not realistically address situations in which thermal/acoustic insulation materials may contribute to protect the aircraft against post crash fire. The purpose of the FAR 25.856(b) is to upgrade the flammability standards and thus to reduce the incidence and severity of cabin fires, particularly those associated to the entry of fire in post crash scenario by increasing the time for passenger to evacuate in case of a survivable crash.

EASA considers that there is a need to define a special condition because the airworthiness requirements of the relevant CS do not contain adequate or appropriate safety standards for product, which in service experience has shown that unsafe conditions may develop.

**SPECIAL CONDITION**

**Amend CS 25.853(a), CS 25.855(d) and define a new requirement CS 25.856 as follows:**

JAR 25.853 Compartment interiors.

(a) *Except for thermal/acoustic insulation materials*, materials (including finishes or decorative surfaces applied to the materials) must meet the applicable test criteria prescribed in part I of appendix F of this part, or other approved equivalent methods, regardless of the passenger capacity of the aeroplane. ”

JAR 25.855 Cargo or baggage compartments.

(d) *Except for thermal/acoustic insulation materials*, all other materials used in the construction of the cargo or baggage compartment must meet the applicable test criteria prescribed in part I of appendix F of this part or other approved equivalent methods. ”

CS 25.856 Insulation materials.

Disclaimer – This document is not exhaustive and it will be updated gradually.





(b) For aeroplanes with a passenger capacity of 20 or greater, thermal/ acoustic insulation materials (including the means of fastening the materials to the fuselage) installed in the lower half of the aeroplane fuselage must meet the flame penetration resistance test requirements of part VII of Appendix F to this part, or other approved equivalent test requirements. This requirement does not apply to thermal/ acoustic insulation installations that the EASA finds would not contribute to fire penetration resistance.

## **PROPOSED APPENDIX F PART VII**

### Part VII— Test Method To Determine the Burnthrough Resistance of Thermal/Acoustic Insulation Materials.

Use the following test method to evaluate the burnthrough resistance characteristics of aircraft thermal/acoustic insulation materials when exposed to a high intensity open flame.

#### (a) Definitions.

Burnthrough time means the time, in seconds, for the burner flame to penetrate the test specimen, and/or the time required for the heat flux to reach 2.0 Btu/ft<sup>2</sup>sec (2.27 W/cm<sup>2</sup>) on the inboard side, at a distance of 12 inches (30.5 cm) from the front surface of the insulation blanket test frame, whichever is sooner. The burnthrough time is measured at the inboard side of each of the insulation blanket specimens. Insulation blanket specimen means one of two specimens positioned in either side of the test rig, at an angle of 30° with respect to vertical. Specimen set means two insulation blanket specimens. Both specimens must represent the same production insulation blanket construction and materials, proportioned to correspond to the specimen size.

#### (b) Apparatus.

(1) The arrangement of the test apparatus is shown in figures 1 and 2 and must include the capability of swinging the burner away from the test specimen during warm-up.

Disclaimer – This document is not exhaustive and it will be updated gradually.





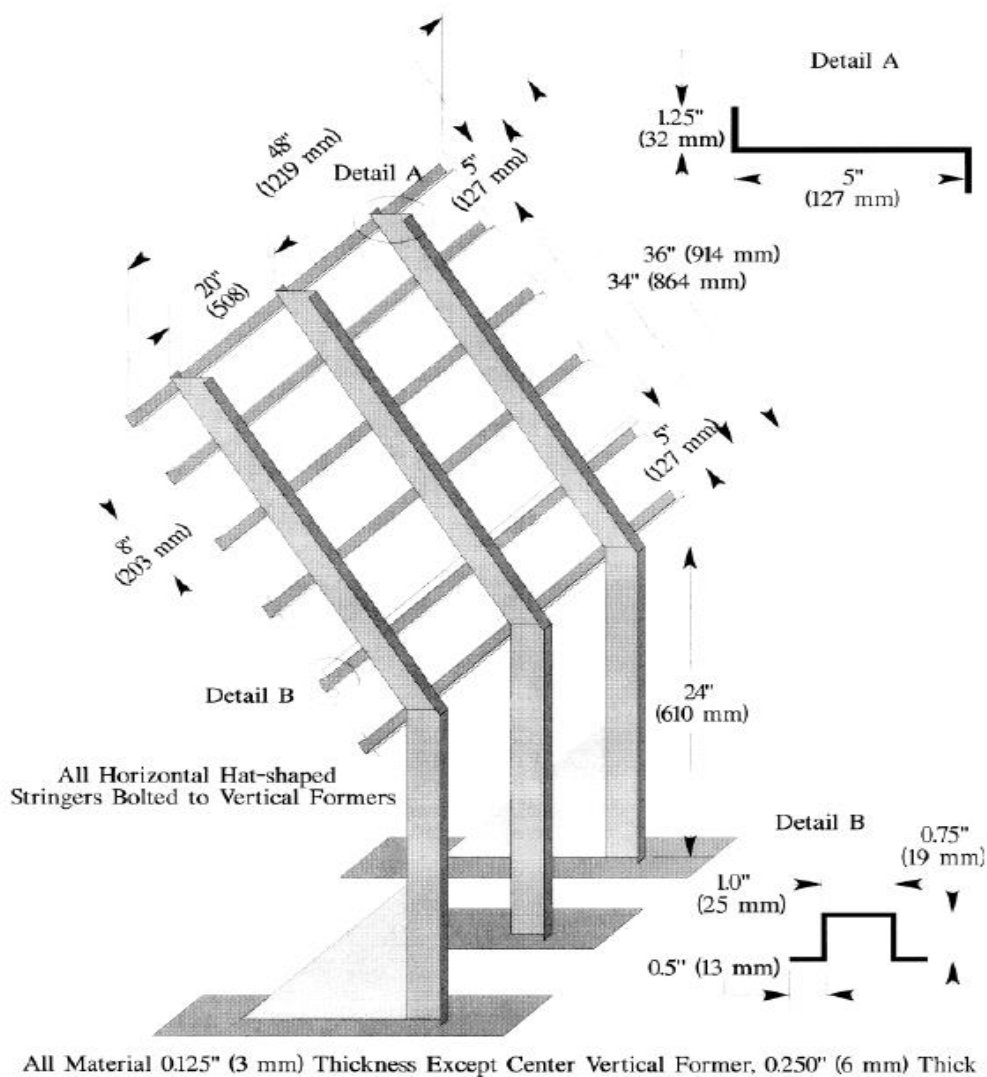

Figure 1 - Burnthrough Test Apparatus Specimen Holder

(2) Test burner. The test burner must be a modified gun-type such as the Park Model DPL 3400. Flame characteristics are highly dependent on actual burner setup. Parameters such as fuel pressure, nozzle depth, stator position, and intake airflow must be properly adjusted to achieve the correct flame output.

Disclaimer – This document is not exhaustive and it will be updated gradually.



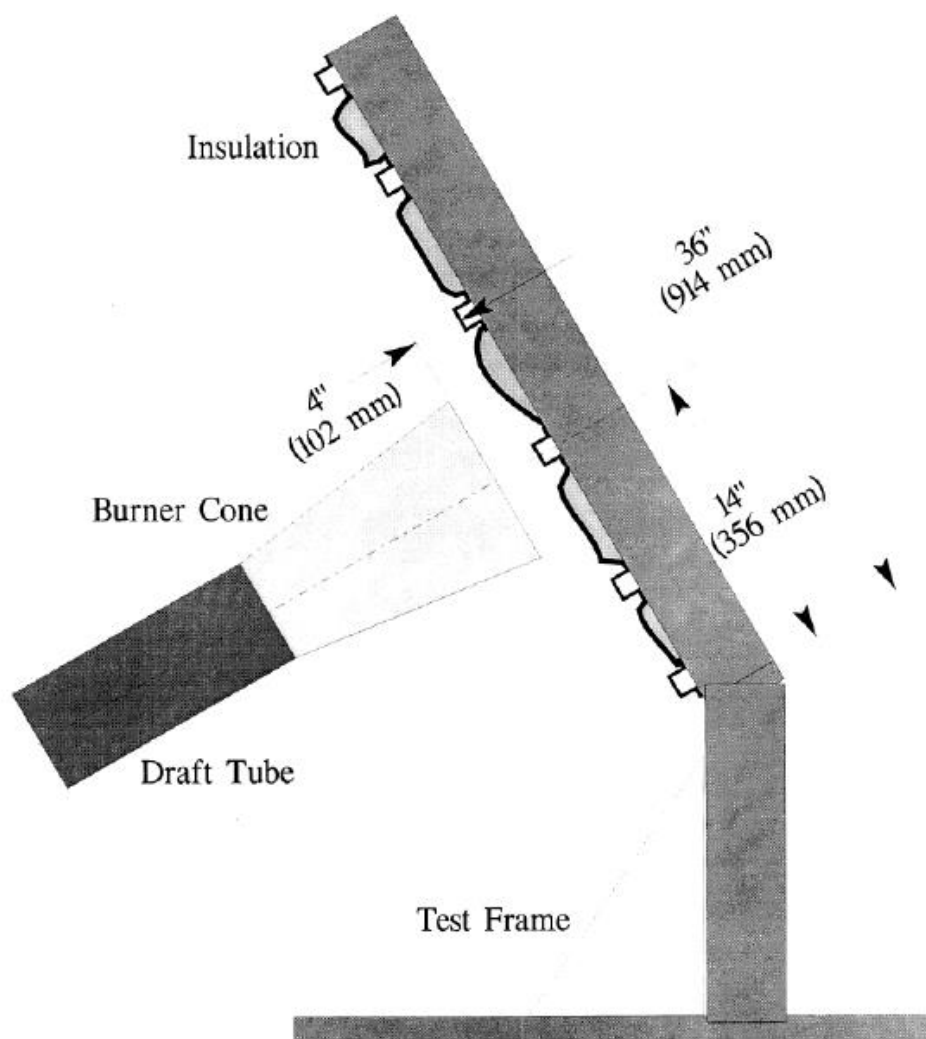

Figure 2 – Burnthrough Test Apparatus

(i) Nozzle. A nozzle must maintain the fuel pressure to yield a nominal 6.0 gal/hr (0.378 L/min) fuel flow. A Monarch-nominally rated at 6.0 gal/hr at 100 lb/in<sup>2</sup> (0.71 MPa) delivers a proper spray pattern.

(ii) Fuel Rail. The fuel rail must be adjusted to position the fuel nozzle at a depth of 0.3125 inch (8 mm) from the end plane of the exit stator, which must be mounted in the end of the draft tube.

(iii) Internal Stator. The internal stator, located in the middle of the draft tube, must be positioned at a depth of 3.75 inches (95 mm) from the tip of the fuel nozzle. The stator must also be positioned such that the integral igniters are located at an angle midway between the

Disclaimer – This document is not exhaustive and it will be updated gradually.

10 and 11 o'clock position, when viewed looking into the draft tube. Minor deviations to the igniter angle are acceptable if the temperature and heat flux requirements conform to the requirements of paragraph VII (e) of this appendix.

(iv) Blower Fan. The cylindrical blower fan used to pump air through the burner must measure 5.25 inches (133 mm) in diameter by 3.5 inches (89 mm) in width.

(v) Burner cone. Install a 12 +0.125-inch (305 +/- 3 mm) burner extension cone at the end of the draft tube. The cone must have an opening 6 +/- 0.125-inch (152 +/- 3 mm) high and 11 +/- 0.125-inch (280 +/- 3 mm) wide (see figure 3).

(vi) Fuel. Use JP-8, Jet A, or their international equivalent, at a flow rate of 6.0 +/- 0.2 gal/hr (0.378 +/- 0.0126 L/min). If this fuel is unavailable, ASTM K2 fuel (Number 2 grade kerosene) or ASTM D2 fuel (Number 2 grade fuel oil or Number 2 diesel fuel) are acceptable if the nominal fuel flow rate, temperature, and heat flux measurements conform to the requirements of paragraph VII (e) of this appendix.

(vii) Fuel pressure regulator. Provide a fuel pressure regulator, adjusted to deliver a nominal 6.0 gal/hr (0.378 L/min) flow rate. An operating fuel pressure of 100 lb/in<sup>2</sup> (0.71MPa) for a nominally rated 6.0 gal/hr 80° spray angle nozzle (such as a PL type) delivers 6.0 +/- 0.2 gal/hr (0.378 +/- 0.0126 L/min).

Disclaimer – This document is not exhaustive and it will be updated gradually.



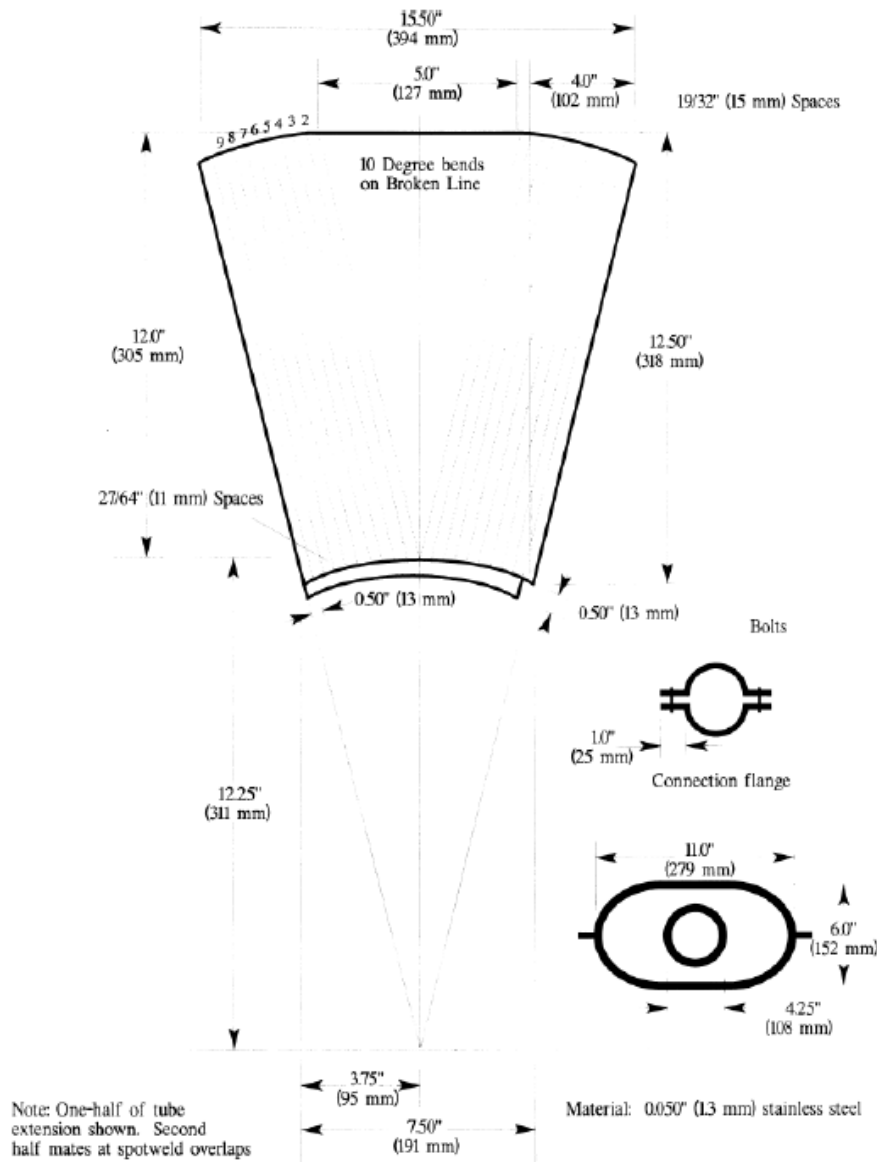

Figure 3 – Burner Draft Tube Extension Cone Diagram

(3) Calibration rig and equipment.

(i) Construct individual calibration rigs to incorporate a calorimeter and thermocouple rake for the measurement of heat flux and temperature. Position the calibration rigs to allow movement of the burner from the test rig position to either the heat flux or temperature position with minimal difficulty.

(ii) Calorimeter. The calorimeter must be a total heat flux, foil type Gardon Gage of an appropriate range such as 0–20 Btu/ft<sup>2</sup>-sec (0–22.7 W/cm<sup>2</sup>), accurate to +/- 3% of the indicated reading. The heat flux calibration method must be in accordance with paragraph VI (b)(7) of this appendix.

Disclaimer – This document is not exhaustive and it will be updated gradually.

(iii) Calorimeter mounting. Mount the calorimeter in a 6- by 12- +/- 0.125 inch (152- by 305- +/- 3 mm) by 0.75 +/- 0.125 inch (19 mm +/- 3 mm) thick insulating block which is attached to the heat flux calibration rig during calibration (figure 4). Monitor the insulating block for deterioration and replace it when necessary. Adjust the mounting as necessary to ensure that the calorimeter face is parallel to the exit plane of the test burner cone.

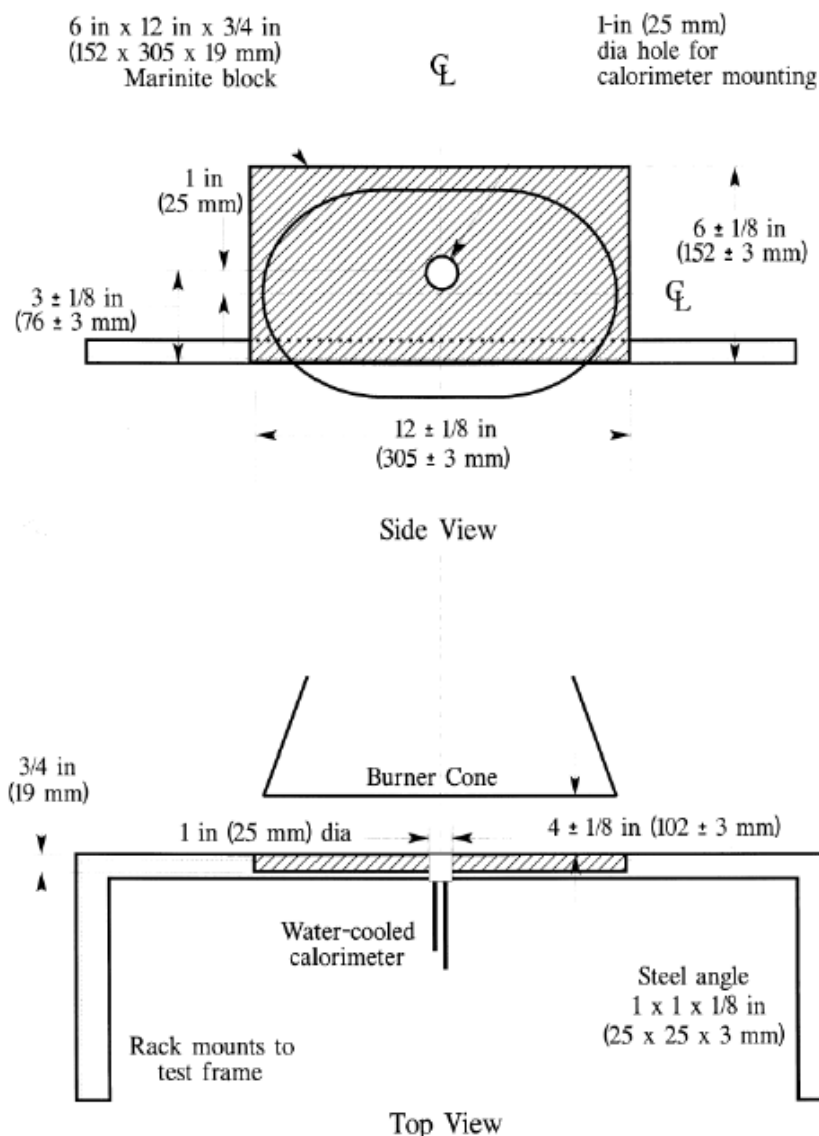

Figure 4 - Calorimeter Position Relative to Burner Cone

(iv) Thermocouples. Provide seven 1/8-inch (3.2 mm) ceramic packed, metal sheathed, type K (Chromel-alumel), grounded junction thermocouples with a nominal 24 American Wire Gauge (AWG) size conductor for calibration. Attach the thermocouples to a steel angle

Disclaimer – This document is not exhaustive and it will be updated gradually.



bracket to form a thermocouple rake for placement in the calibration rig during burner calibration (figure 5).

(v) Air velocity meter. Use a vane-type air velocity meter to calibrate the velocity of air entering the burner. An Omega Engineering Model HH30A is satisfactory. Use a suitable adapter to attach the measuring device to the inlet side of the burner to prevent air from entering the burner other than through the measuring device, which would produce erroneously low readings. Use a flexible duct, measuring 4 inches wide (102 mm) by 20 feet long (6.1 meters), to supply fresh air to the burner intake to prevent damage to the air velocity meter from ingested soot. An optional airbox permanently mounted to the burner intake area can effectively house the air velocity meter and provide a mounting port for the flexible intake duct.

(4) Test specimen mounting frame. Make the mounting frame for the test specimens of 1/8-inch (3.2 mm) thick steel as shown in figure 1, except for the centre vertical former, which should be 1/4-inch (6.4 mm) thick to minimize warpage. The specimen mounting frame stringers (horizontal) should be bolted to the test frame formers (vertical) such that the expansion of the stringers will not cause the entire structure to warp. Use the mounting frame for mounting the two insulation blanket test specimens as shown in figure 2.

(5) Backface calorimeters. Mount two total heat flux Gardon type calorimeters behind the insulation test specimens on the backside (cold) area of the test specimen-mounting frame as shown in figure 6.

Position the calorimeters along the same plane as the burner cone centreline, at a distance of 4 inches (102 mm) from the vertical centreline of the test frame.

Disclaimer – This document is not exhaustive and it will be updated gradually.



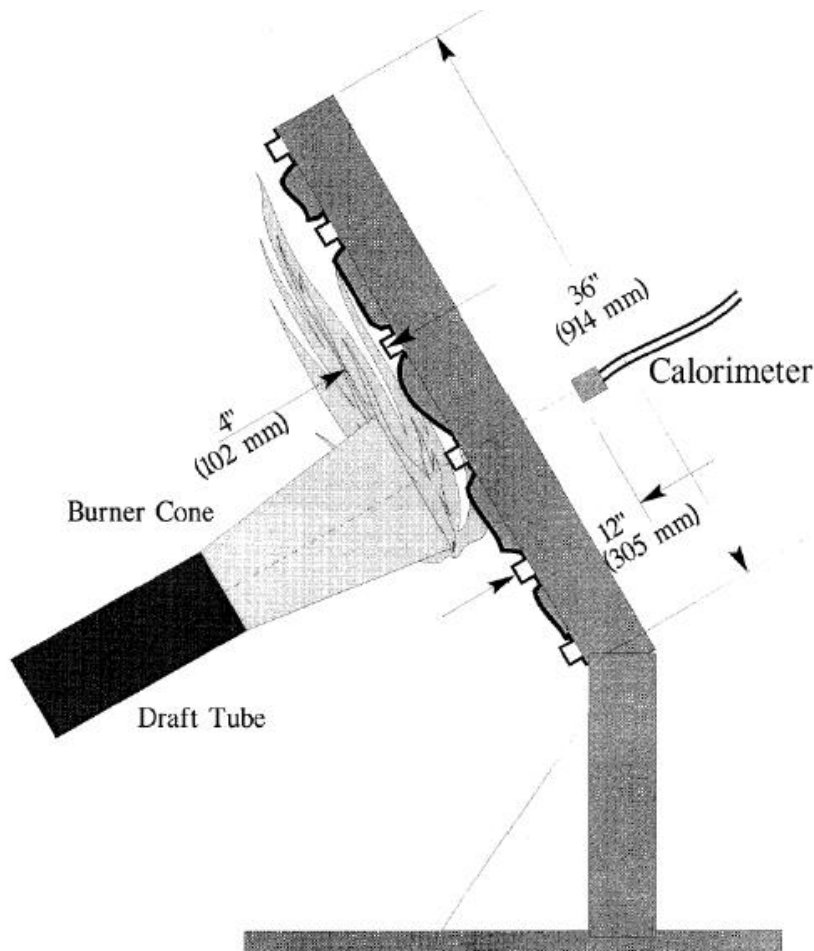

Figure 6 - . Position of Backface Calorimeters Relative to Test Specimen Frame

- (i) The calorimeters must be a total heat flux, foil type Gardon Gage of an appropriate range such as 0–5 Btu/ft<sup>2</sup>-sec (0–5.7 W/cm<sup>2</sup>), accurate to +/- 3% of the indicated reading. The heat flux calibration method must comply with paragraph VI (b)(7) of this appendix.
- (6) Instrumentation. Provide a recording potentiometer or other suitable calibrated instrument with an appropriate range to measure and record the outputs of the calorimeter and the thermocouples.
- (7) Timing device. Provide a stopwatch or other device, accurate to +/- 1%, to measure the time of application of the burner flame and burnthrough time.
- (8) Test chamber. Perform tests in a suitable chamber to reduce or eliminate the possibility of test fluctuation due to air movement. The chamber must have a minimum floor area of 10 by 10 feet (305 by 305 cm).

Disclaimer – This document is not exhaustive and it will be updated gradually.



(i) Ventilation hood. Provide the test chamber with an exhaust system capable of removing the products of combustion expelled during tests.

(c) Test Specimens.

(1) Specimen preparation. Prepare a minimum of three specimen sets of the same construction and configuration for testing.

(2) Insulation blanket test specimen.

(i) For batt-type materials such as fiberglass, the constructed, finished blanket specimen assemblies must be 32 inches wide by 36 inches long (81.3 by 91.4 cm), exclusive of heat sealed film edges.

(ii) For rigid and other non-conforming types of insulation materials, the finished test specimens must fit into the test rig in such a manner as to replicate the actual in-service installation.

(3) Construction. Make each of the specimens tested using the principal components (i.e., insulation, fire barrier material if used, and moisture barrier film) and assembly processes (representative seams and closures).

(i) Fire barrier material. If the insulation blanket is constructed with a fire barrier material, place the fire barrier material in a manner reflective of the installed arrangement. For example, if the material will be placed on the outboard side of the insulation material, inside the moisture film, place it the same way in the test specimen.

(ii) Insulation material. Blankets that utilize more than one variety of insulation (composition, density, etc.) must have specimen sets constructed that reflect the insulation combination used. If, however, several blanket types use similar insulation combinations, it is not necessary to test each combination if it is possible to bracket the various combinations.

(iii) Moisture barrier film. If a production blanket construction utilizes more than one type of moisture barrier film, perform separate tests on each combination. For example, if a polyimide film is used in conjunction with insulation in order to enhance the burnthrough capabilities, also test the same insulation when used with a polyvinyl fluoride film.

(iv) Installation on test frame. Attach the blanket test specimens to the test frame using 12 steel spring type clamps as shown in figure 7. Use the clamps to hold the blankets in place in both of the outer vertical formers, as well as the centre vertical former (4 clamps per former). The clamp surfaces should measure 1 inch by 2 inches (25 by 51 mm). Place the top and bottom clamps 6 inches (15.2 cm) from the top and bottom of the test frame, respectively. Place the middle clamps 8 inches (20.3 cm) from the top and bottom clamps.

Disclaimer – This document is not exhaustive and it will be updated gradually.





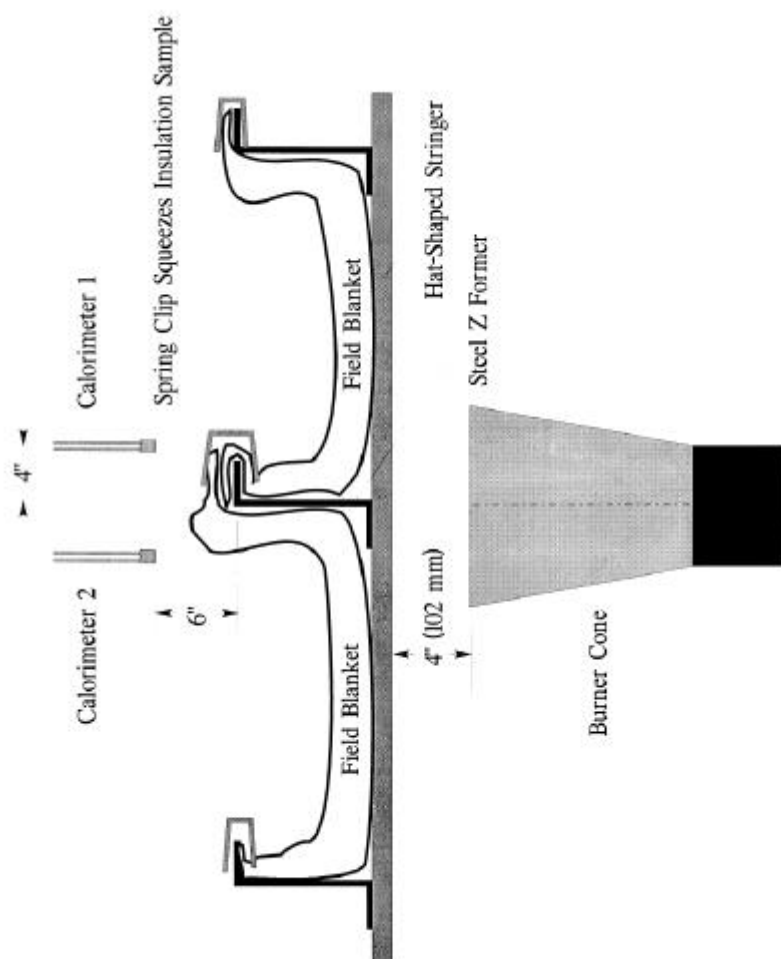

Figure 7 – Test Specimen Installation on Test Frame

(Note: For blanket materials that cannot be installed in accordance with figure 7 above, the blankets must be installed in a manner approved by the FAA.)

(v) Conditioning. Condition the specimens at 70° +/- 5°F (21° +/- 2°C) and 55% +/- 10% relative humidity for a minimum of 24 hours prior to testing.

(d) Preparation of apparatus.

Level and centre the frame assembly to ensure alignment of the calorimeter and/or thermocouple rake with the burner cone.

Turn on the ventilation hood for the test chamber. Do not turn on the burner blower. Measure the airflow of the test chamber using a vane anemometer or equivalent measuring device. The vertical air velocity just behind the top of the upper insulation blanket test specimen must be 100 +/- 50 ft/min (0.51 +/- 0.25 m/s). The horizontal air velocity at this point must be less than 50 ft/min (0.25 m/s).

Disclaimer – This document is not exhaustive and it will be updated gradually.

If a calibrated flow meter is not available, measure the fuel flow rate using a graduated cylinder of appropriate size. Turn on the burner motor/fuel pump, after insuring that the igniter system is turned off. Collect the fuel via a plastic or rubber tube into the graduated cylinder for a 2-minute period. Determine the flow rate in gallons per hour. The fuel flow rate must be 6.0 +/- 0.2 gallons per hour (0.378 +/- 0.0126 L/min).

(e) Calibration.

(1) Position the burner in front of the calorimeter so that it is centred and the vertical plane of the burner cone exit is 4 +/- 0.125 inches (102 +/- 3 mm) from the calorimeter face. Ensure that the horizontal centreline of the burner cone is offset 1 inch below the horizontal centreline of the calorimeter (figure 8). Without disturbing the calorimeter position, rotate the burner in front of the thermocouple rake, such that the middle thermocouple (number 4 of 7) is centred on the burner cone.

Disclaimer – This document is not exhaustive and it will be updated gradually.



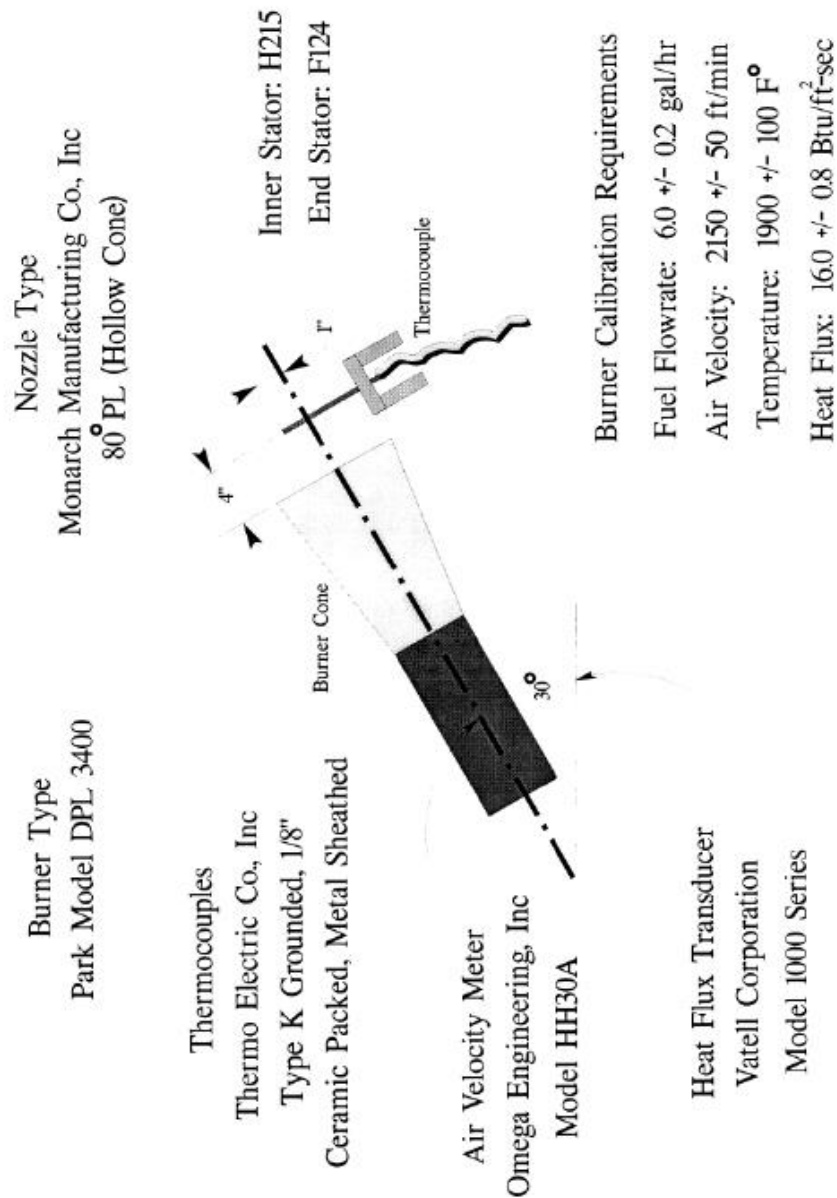

Figure 8 – Burner Information and Calibration Settings

Ensure that the horizontal centreline of the burner cone is also offset 1 inch below the horizontal centreline of the thermocouple tips. Re-check measurements by rotating the burner to each position to ensure proper alignment between the cone and the calorimeter and thermocouple rake. (Note: The test burner mounting system must incorporate “detents” that ensure proper centring of the burner cone with respect to both the calorimeter and the thermocouple rakes, so that rapid positioning of the burner can be achieved during the calibration procedure.)

(2) Position the air velocity meter in the adapter or air box, making certain that no gaps exist where air could leak around the air velocity-measuring device. Turn on the blower/motor while ensuring that the fuel solenoid and igniters are off. Adjust the air intake velocity to a level of 2150 ft/min, (10.92 m/s) and then turn off the blower/motor.

Disclaimer – This document is not exhaustive and it will be updated gradually.



(Note: The Omega HH30 air velocity meter measures 2.625 inches in diameter. To calculate the intake airflow, multiply the cross-sectional area (0.03758 ft<sup>2</sup>) by the air velocity (2150 ft/min) to obtain 80.80 ft<sup>3</sup>/min. An air velocity meter other than the HH30 unit can be used, provided the calculated airflow of 80.80 ft<sup>3</sup>/min (2.29 m<sup>3</sup>/min) is equivalent.)

(3) Rotate the burner from the test position to the warm-up position. Prior to lighting the burner, ensure that the calorimeter face is clean of soot deposits, and there is water running through the calorimeter. Examine and clean the burner cone of any evidence of buildup of products of combustion, soot, etc. Soot buildup inside the burner cone may affect the flame characteristics and cause calibration difficulties. Since the burner cone may distort with time, dimensions should be checked periodically.

(4) While the burner is still rotated to the warm-up position, turn on the blower/motor, igniters and fuel flow, and light the burner. Allow it to warm up for a period of 2 minutes. Move the burner into the calibration position and allow 1 minute for calorimeter stabilization, then record the heat flux once every second for a period of 30 seconds. Turn off burner, rotate out of position, and allow to cool. Calculate the average heat flux over this 30-second duration. The average heat flux should be 16.0 +/- 0.8 Btu/ft<sup>2</sup> sec (18.2 +/- 0.9 W/cm<sup>2</sup>).

(5) Position the burner in front of the thermocouple rake. After checking for proper alignment, rotate the burner to the warm-up position, turn on the blower/motor, igniters and fuel flow, and light the burner. Allow it to warm up for a period of 2 minutes. Move the burner into the calibration position and allow 1 minute for thermocouple stabilization, then record the temperature of each of the 7 thermocouples once every second for a period of 30 seconds. Turn off burner, rotate out of position, and allow to cool. Calculate the average temperature of each thermocouple over this 30-second period and record. The average temperature of each of the 7 thermocouples should be 1900°F +/- 100°F (1038 +/- 56°C)

(6) If either the heat flux or the temperatures are not within the specified range, adjust the burner intake air velocity and repeat the procedures of paragraphs (4) and (5) above to obtain the proper values. Ensure that the inlet air velocity is within the range of 2150 ft/min +/- 50 ft/min (10.92 +/- 0.25 m/s).

(7) Calibrate prior to each test until consistency has been demonstrated. After consistency has been confirmed, several tests may be conducted with calibration conducted before and after a series of tests.

(f) Test procedure.

Secure the two insulation blanket test specimens to the test frame. The insulation blankets should be attached to the test rig centre vertical former using four spring clamps positioned as shown in figure 7 (according to the criteria of paragraph (c)(4) or (c)(4)(i) of this part of this appendix).

Disclaimer – This document is not exhaustive and it will be updated gradually.



Ensure that the vertical plane of the burner cone is at a distance of 4 +/- 0.125 inch (102 +/- 3 mm) from the outer surface of the horizontal stringers of the test specimen frame, and that the burner and test frame are both situated at a 30° angle with respect to vertical.

When ready to begin the test, direct the burner away from the test position to the warm-up position so that the flame will not impinge on the specimens prematurely. Turn on and light the burner and allow it to stabilize for 2 minutes.

To begin the test, rotate the burner into the test position and simultaneously start the timing device.

Expose the test specimens to the burner flame for 4 minutes and then turn off the burner. Immediately rotate the burner out of the test position.

Determine (where applicable) the burnthrough time, or the point at which the heat flux exceeds 2.0 Btu/ft<sup>2</sup>-sec (2.27 W/cm<sup>2</sup>).

(g) Report.

Identify and describe the specimen being tested.

Report the number of insulation blanket specimens tested.

Report the burnthrough time (if any), and the maximum heat flux on the back face of the insulation blanket test specimen, and the time at which the maximum occurred.

(h) Requirements.

(1) Each of the two insulation blanket test specimens must not allow fire or flame penetration in less than 4 minutes.

(3) Each of the two insulation blanket test specimens must not allow more than 2.0 Btu/ft<sup>2</sup>-sec (2.27W/cm<sup>2</sup>) on the cold side of the insulation specimens at a point 12 inches (30.5 cm) from the face of the test rig.

## Acronyms and Abbreviations

<b>FAR</b>	Federal Aviation Regulations
<b>CS</b>	Certification specification
<b>EASA</b>	European Aviation Safety Agency
<b>FAA</b>	Federal Aviation Administration

Disclaimer – This document is not exhaustive and it will be updated gradually.



## E-130: APPLICATION OF HEAT RELEASE AND SMOKE DENSITY REQUIREMENTS TO SEAT MATERIALS

<b>SPECIAL CONDITION</b>	<b>E-130: Application of heat release and smoke density requirements to seat materials</b>
APPLICABILITY:	A330 / A340
REQUIREMENTS:	JAR 25.853(a)(1) Chg. 13, JAR 25.853(c) Chg. 14
ISSUE:	2 Rev.1 dated 04/03/2011

### Special Condition summary

#### SPECIAL CONDITION

1. Except as provided in paragraph 3 of these special conditions, compliance with JAR 25, Appendix F, parts IV and V, heat release and smoke emission, is required for seats that incorporate non- traditional, large, non-metallic panels that may either be a single component or multiple components in a concentrated area in their design.
2. The applicant may designate up to and including 0.13935 m<sup>2</sup> (1.5 square feet) of non-traditional, non-metallic panel material per seat place that does not have to comply with special condition Number 1, above. A triple seat assembly may have a total of 0.41805 m<sup>2</sup> (4.5 square feet) excluded on any portion of the assembly (e.g., outboard seat place 0.0929 m<sup>2</sup> (1 square foot), middle 0.0929 m<sup>2</sup> (1 square foot), and inboard 0.23225 m<sup>2</sup> (2.5 square feet)).
3. Seats do not have to meet the test requirements of JAR 25, Appendix F, parts IV and V, when installed in compartments that are not otherwise required to meet these requirements. Examples include:
  - a. Aeroplanes with passenger capacities of 19 or less and
  - b. Aeroplanes exempted from smoke and heat release requirements.
4. Only aeroplanes associated with new seat certification programs applied for after the effective date of these special conditions will be affected by the requirements in these special conditions. This Special Condition is not applicable to:
  - a. the existing aeroplane fleet and follow-on deliveries of aeroplanes with previously certified interiors;
  - b. For minor layout changes and major layout changes of already certified versions that:
    - does not affect seat design;
    - does not introduce changes to seat design that affect panels that could be defined as “non- traditional, large, non-metallic panels”.

#### Acronyms and Abbreviations

<b>JAR</b>	Joint Aviation Regulation
------------	---------------------------

Disclaimer – This document is not exhaustive and it will be updated gradually.



## **E-134: INSTALLATION OF SEATS THAT MAKE AN ANGLE OF MORE THAN 18° WITH THE AIRCRAFT LONGITUDINAL AXIS**

<b>Equivalent Safety Finding</b>	<b>E-134: Acceptable Means of Compliance: Installation of seats that make an angle of more than 18° with the aircraft longitudinal axis.</b>
APPLICABILITY:	A330/A340
REQUIREMENTS:	JAR 25.785(c) at Change 13, JAR 25.785(d) at Change 14
ISSUE:	2 dated 13/11/2013

### **Equivalent safety finding summary**

#### **BACKGROUND**

Some Cabin of A330 aircraft models will be equipped with B/C seats that form an angle to the aircraft centreline of 25.5°.

“Each occupant of a seat [...] that makes more than an 18° angle with the vertical plane containing the aeroplane centreline must be protected from head injury by a safety belt and an energy absorbing rest that will support the arms, shoulders, head and spine, or by a safety belt and shoulder harness that will prevent the head from contacting any injurious object. Each occupant of any other seat must be protected from head injury by a safety belt and as appropriate to the type, location and angle of facing of each seat, by one or more of the following:

- (1) A shoulder harness that will prevent the head from contacting any injurious object.
- (2) The elimination of any injurious object within striking radius of the head.
- (3) An energy absorbing rest that will support the arms, shoulders, head and spine.”

Airbus has made a request for an Equivalent Safety Finding with JAR 25.785(c) at change 13. It is Airbus intention to demonstrate that this design has an equivalent Level Of Safety to a normal facing seat installation of 0° and hence, makes the energy absorbing rest for arms, head and spine and a shoulder harness required by JAR 25.785(c) at change 13 not necessary.

#### **EQUIVALENT SAFETY FINDINGS**

An equivalent safety finding shall be used for the Long Range A/C by showing compliance to JAR 25.785(c) at Change 13 or JAR 25.785(d) at Change 14 for passenger seats that are installed in the aircraft making an angle up to 30° with the aircraft longitudinal axis by the following:

- 1) The design of the seat and the surrounding items should be developed to maximise the capability of the occupant to align with the deceleration vector during the impact.
- 2) The installation of an airbag-belt system may be required if the occupant does not realign as much as expected or if testing shows that an airbag (that is part of the seat design) would play a significant role in maintaining acceptable protection.

Disclaimer – This document is not exhaustive and it will be updated gradually.





3) ATD internal force and moment measurements, in addition to those required by JAR 25.562 (c), are necessary for comparative purposes. These measurements can be taken during dynamic testing and compared with values from tests conducted on a seat installed at less than 18 degrees with respect to the aircraft centreline. It should be noted that this approach cannot at present involve consideration of absolute values as research data do not exist to back this up. Rather, this will involve a check that the values observed are of comparable magnitude and range and will provide confidence that the mitigating factors are achieving the desired outcome.

4) Seats installed above 30° degrees to the aircraft longitudinal axis must be subject to further discussion in order to identify the need for additional and/or modified conditions for an ESF.

### Acronyms and Abbreviations

<b>JAR</b>	Joint Aviation Regulation
<b>ESF</b>	Equivalent Safety Finding
<b>ATD</b>	Automated Test Dummy
<b>B/C</b>	Business Class
<b>A/C</b>	Aircraft

Disclaimer – This document is not exhaustive and it will be updated gradually.





**E-1014: HIC COMPLIANCE FOR FRONT ROW SEATING(INFLATABLE RESTRAINTS)**

<b>SPECIAL CONDITION</b>	<b>E-1014: HIC Compliance for front row seating(Inflatable Restraints)</b>
APPLICABILITY:	A330 / A340
REQUIREMENTS:	JAR 25.562(c)(5)
ISSUE:	4 dated 19/07/2007

**Special Condition summary**

**SPECIAL CONDITION**

1) HIC Characteristic

The existing means of controlling Head Injury Criterion (HIC) result in an unquantified but nominally predictable progressive reduction of injury severity for impact conditions less than the maximum specified by the rule. Airbag technology however involves a step change in protection for impacts below and above that at which the airbag device deploys. This could result in the HIC being higher at an intermediate impact condition than that resulting from the maximum.

It is acceptable for the HIC to have such a non-linear or step change characteristic provided that the value does not exceed 1000 at any condition at which the inflatable lapbelt does or does not deploy, up to the maximum severity pulse specified by the requirements. Tests must be performed to demonstrate this taking into account any necessary tolerances for deployment.

2) Intermediate Pulse Shape

The existing ideal triangular maximum severity pulse is defined in FAA AC 25.562.1. EASA considers that for the evaluation and testing of less severe pulses, a similar triangular pulse should be used with acceleration, rise time, and velocity change scaled accordingly.

3) Protection during Secondary Impacts

EASA acknowledges that the inflatable lapbelt will not provide protection during secondary impacts after actuation. However, evidence must be provided that the post-deployment features of the installation shall not result in an unacceptable injury hazard. This must include consideration of the deflation characteristics in addition to physical effects. As a minimum, a qualitative assessment shall be provided.

Furthermore, the case where a small impact is followed by a large impact must be addressed. In such a case if the minimum deceleration severity at which the airbag is set to deploy is unnecessarily low, the bag's protection may be lost by the time the second larger impact occurs. It must be substantiated that the trigger point for airbag deployment has been chosen to maximise the probability of the protection being available when needed.

Disclaimer – This document is not exhaustive and it will be updated gradually.



#### 4) Protection of Occupants other than 50th Percentile

The existing policy is to consider other percentile occupants on a judgmental basis only i.e. not using direct testing of inquiry criteria but evidence from head paths etc. to determine likely areas of impact.

The same philosophy may be used for inflatable lapbelts in that test results for other size occupants need not be submitted. However, sufficient evidence must be provided that other size occupants are protected.

A range of stature from a two year old child to a ninety-five percentile male must be considered.

In addition the following situations must be taken into account:

The seat occupant is holding an infant, including the case where a supplemental loop infant restraint is used

- The seat occupant is a child in a child restraint device.
- The seat occupant is a pregnant woman

#### 5) Occupants Adopting the Brace Position

There is no requirement for protection to be assessed or measured for set occupants in any other position or configuration than seated alone upright, as specified in FAA AC 25.562-1A (dated 19 January 1996). However, it must be shown that the inflatable lapbelt does not, in itself, form a hazard to any occupant in a brace position during deployment.

6) It must be shown that the gas generator does not release hazardous quantities of gas or particulate matter into the cabin.

7) It must be ensured by design that the inflatable lapbelt cannot be used in the incorrect orientation (twisted) such that improper deployment would result.

8) The probability of inadvertent deployment must be shown to be acceptably low. The seated occupant must not be seriously injured as a result of the inflatable lapbelt deployment, including when loosely attached.

Inadvertent deployment must not cause a hazard to the aircraft or cause injury to anyone who may be positioned close to the inflatable lapbelt (e.g. seated in an adjacent seat or standing adjacent to the seat). Cases where the inadvertently deploying inflatable lapbelt is buckled or unbuckled around a seated occupant and where it is buckled or unbuckled in an empty seat must be considered.

9) It must be demonstrated that the inflatable lapbelt when deployed does not impair access to the buckle, and does not hinder evacuation, including consideration of adjacent seat places and the aisle.

Disclaimer – This document is not exhaustive and it will be updated gradually.



10) There must be a means for a crew member to verify the integrity of the inflatable lapbelt activation system prior to each flight, or the integrity of the inflatable lapbelt activation system must be demonstrated to reliably operate between inspection intervals.

11) It must be shown that the inflatable lapbelt is not susceptible to inadvertent deployment as a result of wear and tear, or inertial loads resulting from in-flight or ground manoeuvres likely to be experienced in service.

12) The equipment must meet the requirements of JAR 25.1316 with associated guidance material IM S-1006 for indirect effects of lightning.

Electro static discharge must also be considered.

13) The equipment must meet the requirements for HIRF (SC S-10.2) with an additional minimum RF test for the threat from passenger electronic devices of 15 Watts radiated power

14) The inflatable lapbelt mechanisms and controls must be protected from external contamination associated with that which could occur on or around passenger seating.

15) The inflatable lapbelt installation must be protected from the effects of fire such that no hazard to occupants will result.

16) The inflatable lapbelt must provide adequate protection for each occupant regardless of the number of occupants of the seat assembly or adjacent seats considering that unoccupied seats may have active inflatable lapbelts, which may be buckled or unbuckled.

17) Each inflatable lapbelt must function properly following any separation in the fuselage.

18) It is accepted that a material suitable for the inflatable bag that will meet the normally accepted flammability standard for a textile, i.e. the 12 second vertical test of JAR25 Appendix F, Part 1, paragraph (b)(4), is not currently available.

In recognition of the overall safety benefit of inflatable lapbelts, and in lieu of this standard, it is acceptable for the material of the inflatable bags to have an average burn rate of no greater than 2.5 inches/minute when tested using the horizontal flammability test of JAR25 Appendix F, part I, paragraph (b)(5).

See CRI E-1023 for a more detailed discussion of the flammability issue.

Disclaimer – This document is not exhaustive and it will be updated gradually.



---

**Acronyms and Abbreviations**

<b>HIC</b>	Head Injury Criterion
<b>FAA</b>	Federal Aviation Administration
<b>EASA</b>	European Aviation Safety Agency
<b>JAR</b>	Joint Aviation Regulation
<b>HIRF</b>	High Intensity Radiated Fields
<b>RF</b>	Radio Frequency

Disclaimer – This document is not exhaustive and it will be updated gradually.



## **E-1022: IMPROVED FLAMMABILITY STANDARDS FOR THERMAL/ACOUSTIC INSULATION MATERIALS**

<b>Equivalent Safety Finding</b>	<b>E-1022: Improved flammability standards for thermal/acoustic insulation materials</b>
APPLICABILITY:	A330 / A340, A340-500/-600
REQUIREMENTS:	JAR 25.853(b) at change 13 JAR 25.853(a) at change 14 JAR 25.855(d) at change 14 FAR 25.856(a) at amendment 111
ISSUE:	2 dated 01/08/2005

### **Equivalent Safety Finding summary**

#### **BACKGROUND**

The FAA has introduced upgraded flammability standards for thermal and acoustic insulation materials used in transport category aeroplanes through FAR 25 amendment 111, and with FAR 25, Part VI of Appendix F.

FAR 25 amendment 111 introduces new paragraph 25.856, which provides in sub-paragraph (a): new flammability propagation standards and in sub-paragraph (b): new burn through flammability standards.

FAR 25.856(a) introduces higher flammability standards for the thermal / acoustic insulation materials.

According to relevant JAR 25.853, Airbus insulation materials were until now tested to the 12s vertical Bunsen burner. The proposed modification introduces insulation materials tested to the radiant panel, according the requirements of FAR 25.856(a) and Appendix F Part VI. This test consists in the evaluation of the flammability and flame propagation characteristics of the different thermal / acoustic insulation materials, exposed to both a radiant heat source and a flame.

FAR 25.856(a) covers the overall thermal / acoustic insulation materials. Relevant JAR 25.853 applies to the materials used in each compartment occupied by the crew or passengers. FAR 25.856(a) applies to all the thermal / acoustic insulation materials, indifferently installed in pressurized or unpressurized areas.

Therefore, areas covered previously by JAR 25.855(a) at change 13 and by JAR 25.855(d) at change 14 are also impacted. However, JAR 25.855(a) at change 13 compliance is directly fulfilled by compliance with JAR 25.853(b), hence this ESF will only refer to JAR 25.853(b) at change 13, JAR 25.853(a) at change 14 and JAR 25.855(d) at change 14.

All the insulation materials installed on the US-registered aeroplanes manufactured after September 2<sup>nd</sup>, 2005, and the insulation materials installed in the fuselage, that are replaced after September 2<sup>nd</sup>, 2005 on the US-registered aeroplanes have to comply with these new flammability standards.

Disclaimer – This document is not exhaustive and it will be updated gradually.



---

The FAA is requiring that aeroplanes operating in FAR part 121 to comply with the requirements of FAR 25.856(a) before September 2<sup>nd</sup>, 2005.

## **EQUIVALENT SAFETY FINDINGS**

Thermal/acoustic insulation that meets FAR 25.856(a) at Amendment 111 can be considered equivalently safe for the purposes of showing compliance with JAR 25.853(b) at change 13, JAR 25.853(a) at change 14, and JAR 25.855(d) at change 14. Since A330/340 aeroplanes do not have amendment 111 in their certification basis, compliance with JAR 25.853 and JAR 25.855 is still required.

However, once compliance with FAR 25.856(a) has been shown, it is not necessary to test in accordance with JAR 25.853(b) at change 13, JAR 25.853(a) at change 14, and JAR 25.855(d) at change 14, and these requirements can be substantiated based on equivalent safety.

## **Acronyms and Abbreviations**

<b>FAA</b>	Federal Aviation Administration
<b>FAR</b>	Federal Aviation Regulations
<b>JAR</b>	Joint Aviation Regulation
<b>ESF</b>	Equivalent Safety Finding

Disclaimer – This document is not exhaustive and it will be updated gradually.



## E-1023: SIDE FACING SEATS WITH INFLATABLE RESTRAINTS

<b>SPECIAL CONDITION</b>	<b>E-1023: Side Facing Seats with Inflatable Restraints</b>
APPLICABILITY:	A340-500/-600
REQUIREMENTS:	JAR 25.785, 25.562, 25.853
ISSUE:	2 dated 27/12/2005

### Special Condition summary

## SPECIAL CONDITION

### 1. Injury Criteria

(a) Existing Criteria: All injury protection criteria of § 25.562(c)(1) through (c)(6) apply to the occupant of a side facing seat. HIC assessments are only required for head contact with the seat and/or adjacent structures.

(b) Body-to-wall/furnishing contact: The seat must be installed aft of a structure such as an interior wall or furnishing that (perhaps in combination with an inflatable lapbelt) will support the pelvis, upper arm, chest, and head of an occupant seated next to the structure. A conservative representation of the structure and its stiffness and, if applicable, a fully functioning inflatable lapbelt, representative of the final production standard, must be included in the tests.

(c) Thoracic Trauma: Testing with a Side Impact Dummy (SID), as defined by 49 CFR Part 572, Subpart F, or its equivalent, must be conducted and Thoracic Trauma Index (TTI) injury criteria acquired with the SID must be less than 85, as defined in 49 CFR Part 572, Subpart F. SID TTI data must be processed as defined in Federal Motor Vehicle Safety Standard (FMVSS) Part 571.214, section S6.13.5.

(d) Pelvis: Pelvic lateral acceleration must be shown by dynamic tests and/or by rational analysis to not exceed 130g. Pelvic acceleration data must be processed as defined in FMVSS Part 571.214, section S6.13.5.

### 2. Plinths and Pallets Conditions.

It must be demonstrated that the installation of the seats via plinths or pallets meets all applicable airworthiness requirements.

In this regard, compliance to the published guidance contained in FAA Policy PS-ANM 100-2000-00123 dated 22/02/2000 titled “Guidance for Demonstrating Compliance with Seat Dynamic Testing for Plinths and Pallets” will be acceptable to the Agency.

### 3. Inflatable Restraints Conditions.

#### a) HIC Characteristic

Disclaimer – This document is not exhaustive and it will be updated gradually.



The existing means of controlling Head Injury Criterion (HIC), Thoracic Trauma Index and Pelvic Lateral acceleration result in an unquantified but nominally predictable progressive reduction of injury severity for impact conditions less than the maximum specified by the requirements. Airbag technology however involves a step change in protection for impacts below and above that at which the airbag device deploys. This could result in the one or more of the injury criteria being higher at an intermediate impact condition than that resulting from the maximum.

It is acceptable for the injury criteria to have such non-linear or step change characteristics, provided that the values do not exceed the maxima allowed at any condition at which the inflatable lapbelt does or does not deploy, up to the maximum severity pulse specified by the requirements. Tests must be performed to demonstrate this, taking into account any necessary tolerances for deployment.

#### b) Intermediate Pulse Shape

The existing ideal triangular maximum severity pulse is defined in FAA AC 25.562.1. The Agency considers that for the evaluation and testing of less severe pulses, a similar triangular pulse should be used with acceleration, rise time, and velocity change scaled accordingly.

#### c) Protection during Secondary Impacts

The Agency acknowledges that the inflatable lapbelt will not provide protection during secondary impacts after actuation. However, evidence must be provided that the post-deployment features of the installation shall not result in an unacceptable injury hazard. This must include consideration of the deflation characteristics in addition to physical effects. As a minimum, a qualitative assessment shall be provided.

Furthermore, the case where a small impact is followed by a large impact must be addressed. In such a case if the minimum deceleration severity at which the airbag is set to deploy is unnecessarily low, the bag's protection may be lost by the time the second larger impact occurs. It must be substantiated that the trigger point for airbag deployment has been chosen to maximise the probability of the protection being available when needed.

#### d) Protection of Occupants other than 50th Percentile

The existing policy is to consider other percentile occupants on a judgmental basis only i.e. not using direct testing of injury criteria but evidence from head paths etc. to determine likely areas of impact.

The same philosophy may be used for inflatable lapbelts in that test results for other size occupants need not be submitted. However, sufficient evidence must be provided that other size occupants are protected.

A range of stature from a two year old child to a ninety-five percentile male must be considered.

Disclaimer – This document is not exhaustive and it will be updated gradually.





In addition the following situations must be taken into account:

The seat occupant is holding an infant, including the case where a supplemental loop infant restraint is used

- The seat occupant is a child in a child restraint device.
- The seat occupant is a pregnant woman

e) Occupants Adopting the Brace Position

There is no requirement for protection to be assessed or measured for seat occupants in any other position or configuration than seated alone upright, as specified in FAA AC 25.562-1A (dated 19 January 1996). However, it must be shown that the inflatable lapbelt does not, in itself, form a hazard to any occupant in a brace position during deployment.

f) It must be shown that the gas generator does not release hazardous quantities of gas or particulate matter into the cabin.

g) It must be ensured by design that the inflatable lapbelt cannot be used in the incorrect orientation (twisted) such that improper deployment would result.

h) The probability of inadvertent deployment must be shown to be acceptably low. The seated occupant must not be seriously injured as a result of the inflatable lapbelt deployment, including when loosely attached.

Inadvertent deployment must not cause a hazard to the aircraft or cause injury to anyone who may be positioned close to the inflatable lapbelt (e.g. seated in an adjacent seat or standing adjacent to the seat). Cases where the inadvertently deploying inflatable lapbelt is buckled or unbuckled around a seated occupant and where it is buckled or unbuckled in an empty seat must be considered.

i) It must be demonstrated that the inflatable lapbelt when deployed does not impair access to the buckle, and does not hinder evacuation, including consideration of adjacent seat places and the aisle.

j) There must be a means for a crew member to verify the integrity of the inflatable lapbelt activation system prior to each flight, or the integrity of the inflatable lapbelt activation system must be demonstrated to reliably operate between inspection intervals.

k) It must be shown that the inflatable lapbelt is not susceptible to inadvertent deployment as a result of wear and tear, or inertial loads resulting from in-flight or ground manoeuvres likely to be experienced in service.

l) The equipment must meet the requirements of JAR 25.1316 with associated guidance material IM S-1006 for indirect effects of lightning.

Disclaimer – This document is not exhaustive and it will be updated gradually.



Electro static discharge must also be considered.

- m) The equipment must meet the requirements for HIRF (SC S-10.2) with an additional minimum RF test for the threat from passenger electronic devices of 15 Watts radiated power
- n) The inflatable lapbelt mechanisms and controls must be protected from external contamination associated with that which could occur on or around passenger seating.
- o) The inflatable lapbelt installation must be protected from the effects of fire such that no hazard to occupants will result.
- p) Each inflatable lapbelt must function properly following any separation in the fuselage.
- q) The material of the inflatable bags may not have an average burn rate of greater than 2.5 inches/minute when tested using the horizontal flammability test as defined in JAR25 Appendix F, part I, paragraph (b)(5).

### Acronyms and Abbreviations

<b>HIC</b>	Head Injury Criterion
<b>SID</b>	Side Impact Dummy
<b>TTI</b>	Thoracic Trauma Index
<b>FMVSS</b>	Federal Motor Vehicle Safety Standard
<b>FAA</b>	Federal Aviation Administration
<b>HIRF</b>	High Intensity Radiated Fields
<b>SC</b>	Special Condition
<b>RF</b>	Radio Frequency

Disclaimer – This document is not exhaustive and it will be updated gradually.



## F-1: STALLING AND SCHEDULED OPERATING SPEEDS

<b>SPECIAL CONDITION</b>	<b>F-1: Stalling and scheduled operating speeds</b>
APPLICABILITY:	A330 / A340
REQUIREMENTS:	JAR 25.103, 25.107, 25.121, 25.125, 25.201, 25.203, 25.205, 25.207
ISSUE:	6 dated 29/09/1993

### Special Condition summary

## BACKGROUND

The A330 / A340 aircraft models are equipped with a low speed protection system provided against stall a protection that cannot be overridden by the pilot.

The requirement of JAR 25 must therefore be adapted to consider this stall protection function.

## SPECIAL CONDITION

### 1- Definitions

This Special Condition is concerned with novel features of the A330/A340 aircraft models and uses terminology that does not appear in JAR 25.

The following definitions shall apply:

- **High incidence protection system:** A system that operates directly and automatically on the aeroplane's flying controls to limit the maximum incidence that can be attained to a value below that at which an aerodynamic stall would occur.
- **Alpha-floor system:** A system that automatically increases thrust on the operating engines when incidence increases through a particular value.
- **Alpha-limit:** The maximum steady incidence at which the aeroplane stabilises with the high incidence protection system operating and the longitudinal control held on its aft stop.
- **V<sub>min</sub>:** The minimum steady flight speed in the aeroplane configuration under consideration with the high incidence protection system operating. See section 3 of this Special Condition.
- **V<sub>min 1g</sub>:** V<sub>min</sub> corrected to 1 g conditions. See section 3 of this Special Condition.
- **V<sub>s1g</sub>:** The minimum speed in the configuration under consideration at which the aeroplane can develop a lift equal to the weight the aeroplane with engines set to idle thrust. This speed may be demonstrated with the high incidence system adjusted to permit a higher incidence to be achieved, than is possible with the normal production system.

### 2- Capability and Reliability of the High Incidence protection System.

Disclaimer – This document is not exhaustive and it will be updated gradually.



Those paragraphs of JAR 25 quoted in reference may be amended in accordance with Special Condition provided that acceptable capability and reliability of the high incidence protection system can be established by flight test, simulation, and analysis as appropriate. The capability and reliability required are as follows:

- 1- It shall not be possible during pilot induced manoeuvres to encounter a stall and handling characteristics shall be acceptable, as required by section 6 of this Special Condition.
- 2- The aeroplane shall be protected against stalling due to the effects of windshears and gusts at low speeds as required by section 7 of this Special Condition.
- 3- The ability of the high incidence protection system to accommodate any reduction in stalling incidence resulting from residual ice must be verified.
- 4- The reliability of the system and the effects of failures must be acceptable in accordance with JAR 25.1309.

### 3- Minimum Steady Flight Speed and One g Stall Speed

Delete existing JAR 25.103 and replace as follows:

JAR 25.103: Minimum steady flight speed and one g stall speed

- (a) The minimum steady flight speed,  $V_{min}$ , must be determined with:
- (1) The high incidence protection system operating normally.
  - (2) Idle thrust and alpha-floor system inhibited.
  - (3) All combinations of flap settings and landing gear position for which  $V_{min}$  is required to be determined.
  - (4) The weight used when  $V_{s1g}$  is being used as a factor to determine compliance with a required performance standard;
  - (5) The most unfavourable centre of gravity allowable; and
  - (6) The aeroplane trimmed for straight flight at a speed achievable by the automatic trim system.
- (b) The minimum steady flight speed is the final stabilised calibrated airspeed obtained when the aeroplane is decelerated at an entry rate not exceeding 1 knot per second until the longitudinal control is on its stop.
- (c) The one-g minimum steady flight speed,  $V_{min1g}$ , is the minimum calibrated airspeed at which the aeroplane can develop a lift force (normal to the flight path) equal to its weight, whilst at an angle of attack not greater than that at which the minimum steady flight speed of sub-paragraph (b) was determined.
- (d) The one-g stall speed,  $V_{s1g}$ , must be determined with:

Disclaimer – This document is not exhaustive and it will be updated gradually.



- (1) Idle thrust and Alpha-floor system inhibited;
- (2) All combinations of flap settings and landing gear position for which  $V_{s1g}$  is required to be determined;
- (3) The weight used when  $V_{s1g}$  is being used as a factor to determine compliance with a required performance standard;
- (4) The most unfavourable centre of gravity allowable; and
- (5) The aeroplane trimmed for straight flight at a speed achievable by the automatic trim system.

#### 4- Scheduled operating speeds

##### 4.1 Take off Speeds

Delete existing JAR 25.107(b) and replace as follows:

JAR 25.107(b):  $V_2$ , in terms of calibrated airspeed, may not be less than:

- (1)  $1.13 V_{s1g}$
- (2) 1.10 times  $V_{MC}$  established under JAR 25.149
- (3) A speed that provides the manoeuvre capability specified in paragraph 4.4

##### 4.2 Climb one engine inoperative

In JAR 25.121 (c) Final Take-off, amend "at not less than  $1.25 V_s$ ..." to read "...at not less than the greater of  $1.18 V_{s1g}$  and a speed that provides the manoeuvre capability specified in paragraph 4.4, with..."

##### 4.3 Landing Speeds

In JAR 25.125 the value of  $V_{REF}$  used for landing performance determination must not be less than:

- (1)  $1.23 V_{s1g}$
- (2) VMCL established under JAR 25-149(f), (See ACJ 25.125(a)(2))
- (3) A speed that provides the manoeuvre capability specified in paragraph 4.4

##### 4.4 Manoeuvrability at operating speeds

The manoeuvring capabilities in a constant speed coordinated turn at forward centre of gravity, as specified in the table below, must be free of stall warning (if any), or other characteristics which might interfere with normal manoeuvring.

Configuration	Speed	Manoeuvring bank angle in a coordinated turn	Thrust/Power setting
Take-off	$V_2$	30°	Asymmetric WAT-limited (1)
Take-off	$V_2+XX(2)$	40°	All engines climb (3)
En route	$V_{FTO}$	40°	Asymmetric WAT-limited (1)
Landing	$V_{REF}$	40°	Symmetric for -3° flight path angle

- (1) A combination of weight, altitude and temperature (WAT) such that the thrust or power setting produces the minimum climb gradient specified in JAR 25.121 for the flight condition.

Disclaimer – This document is not exhaustive and it will be updated gradually.



- (2) Airspeed approved for all engines initial climb.
- (3) That thrust or power setting which, in the event of failure of the critical engine and without any crew action to adjust the thrust or power of the remaining engines, would result in the thrust or power specified for the take-off condition at  $V_2$ , or any lesser thrust or power setting that is used for all engines-operating initial climb.

## 5- Stall Warning

### 5.1 Normal operation

If the conditions of paragraph 2 are satisfied, equivalent safety to the intent of JAR 25.207, Stall Warning, shall be considered to have been met without provision of an additional, unique warning device.

### 5.2 Failures cases

Following failures of the high incidence protection system, not shown to be extremely improbable, such that capability of the system no longer satisfies items 1, 2 and 3 of paragraph 2 stall warning must be provided in accordance with JAR 25.207(a) and (b).

## 6- Handling Characteristics at High Incidence

### 6.1 High Incidence Handling Demonstrations

Delete existing JAR 25.201 and replace as follows:

#### **JAR 25.201: High incidence handling demonstration**

- (a) Manoeuvres to the limit of the longitudinal control, in the nose up sense, must be demonstrated in straight flight and in 30° banked turns with:
  - (1) The high incidence protection system operating normally.
  - (2) Initial power conditions of:
    - I: Power off
    - II: The power necessary to maintain level flight at  $1.5 V_{s1g}$ , where  $V_{s1g}$  corresponds to the one g stall speed with flaps in approach position, the landing gear retracted and maximum landing weight.
  - (3) Alpha-floor system operating normally unless more severe conditions are achieved with inhibited alpha floor.
  - (4) Flaps, landing gear and deceleration devices in any likely combination of positions
  - (5) Representative weights within the range for which certification is requested; and
  - (6) The aeroplane trimmed for straight flight at a speed achievable by the automatic trim system.
- (b) The following procedures must be used to show compliance with JAR 25.203. (\*)
  - (1) Starting at a speed sufficiently above the minimum steady flight speed to ensure that a steady rate of speed reduction can be established, apply the longitudinal control so that

Disclaimer – This document is not exhaustive and it will be updated gradually.



the speed reduction does not exceed one knot per second until the control reaches the stop

- (2) The longitudinal control must be maintained at the stop until the aeroplane has reached a stabilised flight condition and must then be recovered by normal recovery techniques.
  - (3) The requirements for turning flight manoeuvre demonstrations must also be met with accelerated rates of entry to the incidence limit, up to the maximum rate achievable.
- (\* ) as amended by this special condition

## 6.2 Characteristics in High Incidence Manoeuvres

Delete existing JAR 25.203 and the associated ACJ.

Replace as follows:

### **JAR 25.203: Characteristics in High Incidence Manoeuvres.**

- (a) Throughout manoeuvres with a rate of deceleration of not more than 1 knot per second, both in straight flight and in 30° banked turns, the aeroplane's characteristics shall be as follows:
  - (1) There shall not be any abnormal nose-up pitching.
  - (2) There shall not be any uncommanded nose-down pitching, which would be indicative of stall. However reasonable attitude changes associated with stabilising the incidence at Alpha limit as the longitudinal control reaches the stop would be acceptable
  - (3) There shall not be any uncommanded lateral or directional motion and the pilot must retain good lateral and directional control, by conventional use of the controls, throughout the manoeuvre.
  - (4) The aeroplane must not exhibit severe buffeting of a magnitude and severity that would act as a deterrent to completing the manoeuvre specified in JAR 25.201 (a)\*.
- (\* ) As amended by this Special Condition
- (b) In manoeuvres with increased rates of deceleration some degradation of characteristics is acceptable, associated with a transient excursion beyond the stabilised Alpha-limit. However the aeroplane must not exhibit dangerous characteristics or characteristics that would deter the pilot from holding the longitudinal control on the stop for a period of time appropriate to the manoeuvre.
- (c) It must always be possible to reduce incidence by conventional use of the controls.
- (d) The rate at which the aeroplane can be manoeuvred from trim speeds associated with scheduled operating speeds such as  $V_2$  and  $V_{REF}$  up to Alpha-limit shall not be unduly damped or be significantly slower than can be achieved on conventionally controlled transport aeroplanes.

## 6.3 High Incidence Handling with the Critical Engine Inoperative

Delete existing JAR 25.205 and replace as follows:

### **JAR 25.205: High incidence handling-critical engine inoperative**

Disclaimer – This document is not exhaustive and it will be updated gradually.





- (a) It must be possible to safely recover from a manoeuvre to Alpha-limit with the critical engine inoperative:
- (1) With the high incidence protection system operating normally;
  - (2) Without applying power to the inoperative engine;
  - (3) With high lift devices and landing gear retracted;
  - (4) With the operating engine at up to 75% of maximum continuous power, or up to power at which the wings can be held level with use of maximum control travel (prior to operation of the alpha-floor system) whichever is less; and
  - (5) With the alpha-floor system working normally.
- (b) The operating engine may be throttled back during the recovery from the manoeuvre to Alpha-limit.

## 7- Atmospheric Disturbances

Operation of the high incidence protection system must not adversely affect aircraft control during expected levels of atmospheric disturbances, nor impede the application of recovery procedures in case of windshear.

## 8- Speeds Associated with Other Requirements

JAR 25 specifies requirements that have to be met at speeds quoted as factors of the stall speed  $V_S$ . For the A330 / A340 aircraft models  $V_S$  will be interpreted in each paragraph of the requirements according to the appendix.

## 9- Alpha floor

The Alpha-floor setting must be such that the aircraft can be flown at normal landing operational speeds and manoeuvred up to bank angles consistent with the flight phase without triggering Alpha-floor.

In addition there must be no alpha-floor triggering unless appropriate when aircraft is flown in usual operational manoeuvres and in turbulence.

## APPENDIX TO SPECIAL CONDITION F-1

### 1- Replace JAR 25.21 paragraph (b) by:

- (b) The flying qualities will be evaluated at the most unfavourable CG position.

### 2- In lieu of JAR 25.119 paragraph (b)

- (b) A climb speed which is:
- (1) not less than

Disclaimer – This document is not exhaustive and it will be updated gradually.





- i)  $1.08 V_{s1g}$  for aeroplanes with four engines on which the application of power results in significant reduction in stalling speed; or
  - ii)  $1.13 V_{s1g}$  for all other aeroplanes
- (2) not less than  $V_{MCL}$ ; and
  - (3) not more than the greater of  $V_{REF}$  and  $V_{MCL}$

3- Replace JAR 25.121 paragraph (d) by:

- (d) Discontinued approach. In a configuration in which  $V_{s1g}$  does not exceed 110% of the  $V_{s1g}$  for the related all-engines operating landing configuration, the steady gradient may not be less than 2.1% for two engines aeroplanes, and 2.7% for four engines aeroplanes with:
- (1) the critical engine inoperative, the remaining engines at the available take off thrust;
  - (2) the maximum landing weight; and
  - (3) a climb speed established in connexion with normal landing procedures; but not exceeding  $1.41 V_{s1g}$ .

4- Replace the speeds  $V_s$  mentioned in the following JAR 25 requirements as follows:

JAR 25.145 (a)  $V_{min}$  in lieu of  $V_s$

JAR 25.145 (b) (1)  $1.32 V_{s1g}$  in lieu of  $1.4 V_{s1}$

JAR 25.145 (b) (4)  $1.32 V_{s1g}$  in lieu of  $1.4 V_{s1}$

JAR 25.145 (b) (6)  $1.32 V_{s1g}$  in lieu of  $1.4 V_{s1}$

$V_{min}$  in lieu of  $1.1 V_{s1}$

$1.6 V_{s1g}$  in lieu of  $1.7 V_{s1}$

JAR 25.145 (c)  $1.13 V_{s1g}$  in lieu of  $1.2 V_{s1}$

JAR 25.147 (a)  $1.3 V_{s1g}$  in lieu of  $1.4 V_{s1}$

JAR 25.147 (a) (2)  $1.3 V_{s1g}$  in lieu of  $1.4 V_{s1}$

JAR 25.147 (c)  $1.3 V_{s1g}$  in lieu of  $1.4 V_{s1}$

JAR 25.147 (d)  $1.3 V_{s1g}$  in lieu of  $1.4 V_{s1}$

JAR 25.149 (c)  $1.13 V_{s1g}$  in lieu of  $1.2 V_{s1}$

JAR 25.161 (b)  $1.3 V_{s1g}$  in lieu of  $1.4 V_{s1}$

JAR 25.161 (c) (1)  $1.3 V_{s1g}$  in lieu of  $1.4 V_{s1}$

JAR 25.161 (c) (2)  $1.3 V_{s1g}$  in lieu of  $1.4 V_{s1}$

JAR 25.161 (c) (3)  $1.3 V_{s1g}$  in lieu of  $1.4 V_{s1}$

JAR 25.161 (d)  $1.3 V_{s1g}$  in lieu of  $1.4 V_{s1}$

JAR 25.175 (a) not applicable, see SC F-3

JAR 25.175 (d) not applicable, see SC F-3

JAR 25.177 (a)  $1.13 V_{s1g}$  in lieu of  $1.2 V_{s1}$

JAR 25.177 (b)(1)  $1.13 V_{sg}$  to  $1.23 V_{s1g}$  in lieu of

$1.2 V_{s1}$  to  $1.3 V_{s1}$

JAR 25.177 (b) (2)  $1.13 V_{s1g}$  to  $1.23 V_{s1g}$  in lieu of

$1.2 V_{s1}$  to  $1.3 V_{s1}$

JAR 25.177 (b)(3)  $1.23 V_{s1g}$  in lieu of  $1.3 V_{s1}$

JAR 25.233 (a) replace  $0.2 V_{so}$  by  $0.2 V_{s1g}$

Disclaimer – This document is not exhaustive and it will be updated gradually.



- JAR 25.237 0.94  $V_{s1g}$  in lieu of  $V_{so}$   
 JAR 25.735 (f) (2) 0.94  $V_{s1g}$  in lieu of  $V_{so}$   
 JAR 25.773 (b)(1)(i) 1.5  $V_{s1g}$  in lieu of 1.6  $V_{s1}$   
 JAR 25.1001 (c)(1) .94  $V_{s1g}$  in lieu of  $V_{s1}$   
 JAR 25.1001 (c) (3) .94  $V_{s1g}$  in lieu of  $V_{s1}$   
 JAR 25.1323(c) (1) (i) .94  $V_{s1g}$  in lieu of  $V_{s1}$   
 JAR 25.1323(c) (1) (ii) .94  $V_{s1g}$  in lieu of  $V_{so}$   
 JAR 25.1323 (c) (2) "From 1.3 x 0.94  $V_{s1g}$  to  $V_{min}$ " in lieu of  
     "1.3  $V_s$  to stall warning speed" and  
     "speeds below  $V_{min}$ " in lieu of  
     "speeds below stall warning"  
 JAR 25.1325(e) replace 1.3 $V_{s0}$  by 1.3 x .94  $V_{s1g}$  and  
     1.8 $V_{s1}$  by 1.8 x .94  $V_{s1g}$

### Acronyms and Abbreviations

<b>JAR</b>	Joint Aviation Regulation
<b>WAT</b>	Weight Altitude Temperature
<b>ACJ</b>	Advisory Circular Joint

Disclaimer – This document is not exhaustive and it will be updated gradually.



## F-2: MOTION AND EFFECT OF COCKPIT CONTROLS

<b>SPECIAL CONDITION</b>	<b>F-2: Motion and effect of cockpit controls</b>
APPLICABILITY:	A330 / A340
REQUIREMENTS:	JAR 25.143, JAR 25.777
ISSUE:	2 dated 11/03/1991

### Special Condition summary

## BACKGROUND

The A330 / A340 aircraft models are equipped with a side stick control system. The current requirements JAR 25.143 and JAR 25.777 must be adapted to side stick controls.

## SPECIAL CONDITION

### 1. Add to paragraph JAR 25.777(b):

Pitch and roll control force and displacement sensitivity shall be compatible, so that normal inputs on one control axis will not cause significant unintentional inputs on the other.

### 2. Introduce new paragraph JAR 25.143(i):

Pilot strength:

In lieu of the "strength of pilots" limits shown in 25.143(c) for pitch and roll, and in lieu of specific pitch force requirement of 25.145(b) and 25.175(d), it must be shown that the temporary and maximum prolonged force levels for the side stick controllers are suitable for all expected operating conditions and configurations, whether normal or non-normal.

### 3. Introduce new paragraph JAR 25.143(j):

Pilot control:

It must be shown by flight tests that turbulence does not produce unsuitable pilot-in-the-loop control problems when considering precision path control/tasks.

### 4. Introduce new paragraph JAR 25.143(k):

When a flight case exists where, without being commanded by the crew, control surfaces are coming so close to their limits that return to normal flight envelope and (or) continuing of safe flight request a specific crew action, a suitable flight control position annunciation shall be provided to the crew, unless other existing indications are found adequate or sufficient to prompt that action.

## Acronyms and Abbreviations

<b>JAR</b>	Joint Aviation Regulation
------------	---------------------------

Disclaimer – This document is not exhaustive and it will be updated gradually.



---

### F-3: STATIC LONGITUDINAL STABILITY

<b>SPECIAL CONDITION</b>	<b>F-3: Static longitudinal stability</b>
APPLICABILITY:	A330 / A340
REQUIREMENTS:	JAR 25.171, 25.173, 25.175, SC F-1
ISSUE:	2 dated 11/03/1991

#### Special Condition summary

#### BACKGROUND

The A330/A340 longitudinal control laws provide a neutral stability within the normal flight envelope. Therefore, the A/C design does not literally comply with the static longitudinal stability requirements of JAR 25.171, 25.173 and 25.175.

These requirements must consequently be replaced by the following special condition:

#### SPECIAL CONDITION

The aircraft shall be shown to have suitable stability in any condition normally encountered in service, including the effects of atmospheric disturbances.

#### Acronyms and Abbreviations

<b>JAR</b>	Joint Aviation Regulation
------------	---------------------------

Disclaimer – This document is not exhaustive and it will be updated gradually.



## F-4: STATIC DIRECTIONAL AND LATERAL STABILITY

<b>SPECIAL CONDITION</b>	<b>F-4: Static directional and lateral stability</b>
APPLICABILITY:	A330 / A340
REQUIREMENTS:	JAR 25.177(c)
ISSUE:	2 dated 11/03/1991

### Special Condition summary

#### BACKGROUND

JAR 25.177 is not adapted to the A330/A340 roll axis control feature.

These requirements must consequently be replaced by the following special condition:

#### SPECIAL CONDITION

**JAR 25.177(c) is replaced by the following:**

In straight, steady sideslips (unaccelerated forward slips) the rudder control movements and forces must be substantially proportional to the angle of sideslip, and the factor of proportionality must be between limits found necessary for safe operation throughout the range of sideslip angles appropriate to the operation of the aeroplane. At greater angles up to the angles at which full rudder control is used or a rudder pedal force of 180 pounds is obtained, the rudder pedal forces may not reverse and increased rudder deflection must produce increased angles of sideslip. Unless the aeroplane has a sideslip indication there must be enough bank and lateral control deflection and force accompanying sideslipping to clearly indicate any departure from steady unyawed flight.

#### Acronyms and Abbreviations

<b>JAR</b>	Joint Aviation Regulation
------------	---------------------------

Disclaimer – This document is not exhaustive and it will be updated gradually.



## F-5: FLIGHT ENVELOPE PROTECTIONS

<b>SPECIAL CONDITION</b>	<b>F-5: Flight envelope protections</b>
APPLICABILITY:	A330 / A340
REQUIREMENTS:	JAR 25.143(g)
ISSUE:	2 dated 11/03/1991

### Special Condition summary

## BACKGROUND

The A330/A340 has flight envelope protections (high and low speed, Angle of Attack) implemented in the EFCS. This unusual feature is addressed by the following special condition:

## SPECIAL CONDITION

### Add a new paragraph 25.143 (g):

#### Normal operation:

1) Onset characteristic of each envelope protection feature must be smooth, appropriate to the phase of flight and type of manoeuvre and not in conflict with the ability of the pilot to satisfactorily change aeroplane flight path, or attitude as needed.

2) Limit values of protected flight parameters must be compatible with:

- a) Aeroplane structural limits,
- b) Required safe and controllable manoeuvring of the aeroplane and,
- c) Margin to critical conditions.

Unsafe flight characteristics/conditions must not result from:

- Dynamic manoeuvring,
- Airframe and system tolerances (both manufacturing and in-service), and
- Non-steady atmospheric conditions, in any appropriate combination and phase of flight, if this manoeuvring can produce a limited flight parameter beyond the nominal design limit value.

Note: Reference may be made to FAA Advisory Circular AC 120-41 for guidance on atmospheric conditions.

3) The aeroplane must respond to intentional dynamic manoeuvring within a suitable range of the parameter limit. Dynamic characteristics such as damping and overshoot must also be appropriate for the flight manoeuvre and limit parameter concerned.

4) When simultaneous envelope limiting is engaged, adverse coupling or adverse priority must not result.

Disclaimer – This document is not exhaustive and it will be updated gradually.



---

**Failure states:**

EFCS (including sensor) failures must not result in a condition where a parameter is limited to such a reduced value that safe and controllable manoeuvring is no longer available. The crew must be alerted by suitable means if any change in envelope limiting or maneuverability is produced by single or multiple failures of the EFCS not shown to be extremely improbable.

**Acronyms and Abbreviations**

<b>EFCS</b>	Electrical Flight Control System
<b>JAR</b>	Joint Aviation Regulation

Disclaimer – This document is not exhaustive and it will be updated gradually.



## F-6: NORMAL LOAD FACTOR LIMITING SYSTEM

<b>SPECIAL CONDITION</b>	<b>F-6: Normal load factor limiting system</b>
APPLICABILITY:	A330 / A340
REQUIREMENTS:	JAR 25.143
ISSUE:	2 dated 11/03/1991

### Special Condition summary

#### BACKGROUND

The A330/A340 has a normal load factor limiting feature implemented in the flight control laws. A special condition is necessary to address this unusual feature.

#### SPECIAL CONDITION

##### Add a new paragraph JAR 25.143 (h):

In the absence of other limiting factors

1. The positive limiting load factor must not be less than 2.5 g (2.0 g with high-lift devices extended) for the EFCS normal state.
2. The negative limiting load factor must be equal to or more negative than minus 1,0 g (0 g with high lift devices extended) for the EFCS normal state.

#### Acronyms and Abbreviations

<b>JAR</b>	Joint Aviation Regulation
<b>EFCS</b>	Electrical Flight Control System

Disclaimer – This document is not exhaustive and it will be updated gradually.





## F-8: ACCELERATE STOP DISTANCES

SPECIAL CONDITION	F-8: Accelerate stop distances
APPLICABILITY:	A330 / A340
REQUIREMENTS:	JAR 1.1, 1.2, JAR 25.101, 105, 109, 113, 115, 735, 25x1591, NPA 25-244
ISSUE:	5 dated 14/03/1996

### Special Condition summary

## BACKGROUND

The applicable JAR for A330/A340 aircraft models certification includes the amendments introduced by FAR 25 amendment 42 / JAR 25 change 5.

These requirements were the subject of a review by the aviation community through NPA 25B, D, G-244 in order to establish new standards that would be applicable not only to new types but also to derivative models and even, for some parts, to in-service aircraft.

It is proposed to apply these revised requirements to A330/A340 aircraft by means of a special condition based on this NPA.

## SPECIAL CONDITION

### 1. Proposed amendments to JAR 1.

1.1. Add definitions of "Take-off decision speed" and "Screen height" to JAR 1.1 as follows :  
"Take-off decision speed" means a speed in the take-off at which, if the pilot activates the first deceleration device (spoilers, brakes, throttles, etc...) at this speed, the aeroplane can be stopped within the accelerate-stop distance and, alternatively, if the take-off is continued beyond this speed with the critical engine failed at  $V_{EF}$ , the aeroplane can achieve the take-off screen height within the take-off distance.

"Screen height" means the height of an imaginary screen which the aeroplane would just clear when taking off or landing in an unbanked attitude with landing gear extended.

1.2. Add a definition of the abbreviation  $V_{EF}$  to JAR 1.2 as follows:

" $V_{EF}$ " means the speed at which the critical engine is assumed to fail-during take-off.

### 2. Proposed amendments to JAR 25.

#### 2.1. Amendment to JAR 25 .101 : General

Add a new sub-paragraph (i) to read as follows:

(i) The accelerate-stop and landing distances prescribed in JAR 25.109 and 25.125, respectively, must be determined with all the aircraft brake assemblies on the fully worn limit of their allowable wear range.

Disclaimer – This document is not exhaustive and it will be updated gradually.



## 2.2. Amendment to JAR 25.105 : Take-off

Amend Sub-paragraph (c) to read as follows:

(c) The take-off data must be based on smooth, dry and wet, hard-surfaced runways

## 2.3. Amendment to JAR 25.109 : Accelerate-stop distance

Amend sub-paragraph (a), add a new sub-paragraph (b), re-designate existing (b) as sub-paragraph (c), add a new sub-paragraph (d) and re-designate existing sub-paragraph (c) and (d) as (e) and (f) respectively JAR 25.109 would thus read as follows:

(a) The accelerate-stop distance on a dry runway is the greater of the following distances :

(1) The sum of the distances necessary to:

- (i) Accelerate the aeroplane from a standing start with all engines operating to  $V_{EF}$  for take-off from a dry runway;
- (ii) Accelerate the aeroplane from  $V_{EF}$  to  $V_1$ , assuming the critical engine fails at  $V_{EF}$ ; and
- (iii) Come to a full stop on a dry runway from the point reached at the end of the acceleration period prescribed in sub-paragraph (a)(1)(ii) of this paragraph, assuming that the pilot does not apply any means to retard the aeroplane until that point is reached; plus
- (iv) A distance equivalent to 2 seconds at  $V_1$  for take-off from a dry runway.

(2) The sum of the distances necessary to:

- (i) Accelerate the aeroplane from a standing start with all engines operating to  $V_1$  for take-off from a dry runway; and
- (ii) Come to a full stop on a dry runway from the point reached at the end of the acceleration period prescribed in sub-paragraph (a)(2)(i) of this paragraph, assuming that the pilot does not apply any means to retard the aeroplane until that point is reached; plus
- (iii) A distance equivalent to 2 seconds at  $V_1$  for take-off from a dry runway.

(b) The accelerate-stop distance on a wet runway is the greater of the following distances:

(1) The accelerate-stop distance on a dry runway determined in accordance with sub-paragraph (a) of this paragraph.

(2) The accelerate-stop distance determined in accordance with sub-paragraph (a) of this paragraph except that the runway is wet and the corresponding values of  $V_{EF}$  and  $V_1$  are used. The wet runway stopping requirements of this paragraph must be determined assuming a braking coefficient of friction equal to one half the dry runway braking coefficient determined in meeting the requirements of sub-paragraph (a) of this paragraph, unless a higher wet runway braking coefficient of friction has been demonstrated. (See ACJ 25.109(b)).

(c) (As existing sub-paragraph (b)).

(d) The effects of available reverse thrust.

Disclaimer – This document is not exhaustive and it will be updated gradually.



- (1) May not be included as an additional means of deceleration when determining the accelerate-stop distance on a dry runway, and
- (2) May be included as an additional means of deceleration using recommended reverse thrust procedures when determining the accelerate-stop distance on a wet runway, provided the requirements of sub-paragraph (c) of this paragraph are met.

(e) (As existing sub-paragraph (c)).

(f) (As existing sub-paragraph (d)).

#### 2.4. ACJ 25.109 (b)

Add a new ACJ 25 .109( b) to read as follows:

ACJ 25.109(b)

### Means of Compliance

[See Jar 25.109(b)]

The means of demonstrating a wet braking coefficient of friction greater than one half of the dry value shall be agreed with the Authority. It should be determined whether the demonstrated performance is applicable to the full range of wet runway surface conditions that are expected to be encountered in service. Alternatively, the use of performance based on a braking coefficient of friction greater than one half of the dry value shall be restricted to specified runway and/or to the provision and maintenance of a specified runway surface condition.

### Acronyms and Abbreviations

<b>JAR</b>	Joint Aviation Regulation
<b>NPA</b>	Notice of Proposal Amendment
<b>FAR</b>	Federal Aviation Regulations
<b>ACJ</b>	Advisory Circular Joint

Disclaimer – This document is not exhaustive and it will be updated gradually.



## F-8.1: ACCELERATE STOP DISTANCES AND RELATED PERFORMANCE

<b>SPECIAL CONDITION</b>	<b>F-8.1: Accelerate stop distances and related performance</b>
APPLICABILITY:	A330 / A340
REQUIREMENTS:	JAR 1.1, 1.2, JAR 25.101, 105, 109, 113, 115, 735, 25x1591, NPA 25B, D, G-244
ISSUE:	5 dated 14/03/1996

### Special Condition summary

## BACKGROUND

The applicable JAR for A330/A340 aircraft models certification includes the amendments introduced by FAR 25 amendment 42 / JAR 25 change 5.

These requirements were the subject of a review by the aviation community through NPA 25B, D, G-244 in order to establish new standards that would be applicable not only to new types but also to derivative models and even, for some parts, to in-service aircraft.

It is proposed to apply these revised requirements to A330/A340 aircraft by means of a special condition based on this NPA.

## SPECIAL CONDITION

### 1. Amendments to JAR 1

**1.1** Amend the definition of  $V_1$  in JAR 1.2 as follows:

" $V_1$ " means the maximum speed in the take-off at which the pilot must take the first action (e.g. apply brakes, reduce thrust, deploy speed brakes) to stop the aeroplane within the accelerate-stop distance.  $V_1$  also means the minimum speed in the take-off, following a failure of the critical engine at  $V_{EF}$ , at which the pilot can continue the take-off and achieve the required height above the take-off surface within the take-off distance.

**1.2** Add a definition of the abbreviation  $V_{EF}$  to JAR 1.2 as follows:

" $V_{EF}$ " means the speed at which the critical engine is assumed to fail during take-off.

### 2. Amendment to JAR 25.101 : General

Amend sub-paragraph (i) to read as follows:

- (i) The accelerate-stop and landing distances prescribed in JAR 25.109 and 25.125, respectively, must be determined with all the aircraft brake assemblies at the fully worn limit of their allowable wear range.

### 3. Amendment to JAR 25.105 Take-off :

Amend sub-paragraph (c) to read as follows:

- (c) The take-off data must be based on:

Disclaimer – This document is not exhaustive and it will be updated gradually.



- (1) Smooth, dry and wet, hard-surfaced runways and, optionally;
- (2) Grooved and/or porous friction course wet, hard-surfaced runways;

#### **4. Amendment to JAR 25.109; Accelerate-stop distance:**

Amend JAR 25.109 to read as follows:

- (a) The accelerate-stop distance on a dry runway is the greater of the following distances:
  - (1) The sum of the distance necessary to:
    - (i) Accelerate the aeroplane from a standing start with all engines operating to  $V_{EF}$  for take-off from a dry runway.
    - (ii) Accelerate the aeroplane from  $V_{EF}$  to  $V_1$  and subsequently to the highest speed reached, assuming the critical engine fails at  $V_{EF}$  and,
    - (iii) Come to a full stop on a dry runway from the point reached at the end of the acceleration period prescribed in sub-paragraph 4.(a)(1)(ii), assuming that the pilot does, not apply any means to retard the aeroplane until  $V_1$  is reached; plus
    - (iv) A distance equivalent to 2 seconds at  $V_1$  for take-off from a dry runway.
  - (2) The sum of the distance necessary to
    - (i) Accelerate the aeroplane from a standing start with all engines operating to  $V_1$  for take-off from a dry runway and subsequently to the highest speed reached and
    - (ii) Come to a full stop on a dry runway from the point reached at the end of the acceleration period prescribed in sub-paragraph 4.(a)(2)(i), assuming that the pilot does not apply any means to retard the aeroplane until  $V_1$  is reached, and that all engines are still operating; plus
    - (iii) A distance equivalent to 2 seconds at  $V_1$  for take-off from a dry runway.
- (b) The accelerate-stop distance on a wet runway is the greater of the following distances;
  - (1) The accelerate stop-distance on a dry runway determined in accordance with sub-paragraph 4.(a): or
  - (2) The accelerate-stop distance determined in accordance with sub-paragraph 4.(a), except that the runway is wet and the corresponding wet runway values of  $V_{EF}$  and  $V_1$  are used. The wet runway stopping requirements of this paragraph must be determined assuming for smooth wet runways, the braking coefficient of friction versus speed determined using the standard, and not exceeding the braking coefficient of friction determined in meeting the requirements of Sec.25.101(i) and sub-paragraph 4.(a).

Optionally, for acceptably maintained grooved or porous friction course runways, a braking coefficient of friction not more than 70% of the demonstrated dry-runway, anti-skid controlled braking coefficient determined in meeting the requirements of Sec. 25.101(i) and sub-paragraph (a) of this section.

Alternatively, for acceptably maintained grooved or porous friction course runways, the braking coefficient of friction versus speed determined using the standard, and meeting the requirements of Sec.25.101(i) and sub-paragraph (a) of this section.

Disclaimer – This document is not exhaustive and it will be updated gradually.



- (c) Except as provided in sub-paragraph 4.(d)(1), means other than wheel brakes may be used to determine the accelerate-stop distance if that means:
  - (1) is safe and reliable.
  - (2) is used so that consistent results can be expected under normal operating conditions;
  - and
  - (3) is such that exceptional skill is not required to control the aeroplane
- (d) The effects of available reverse thrust.
  - (1) Shall not be included as an additional means of deceleration when determining the accelerate-stop distance on a dry runway and
  - (2) May be included as an additional means of deceleration using recommended reverse thrust procedures when determining the accelerate-stop distance on a wet runway, provided the requirements of sub-paragraph 4.(c) are met.
- (e) The landing gear must remain extended throughout the accelerate-stop distance.
- (f) If the accelerate-stop distance includes a stop way with surface characteristics substantially different from those of the runway, the take-off data must include operational correction factors for the accelerate-stop distance. The correction factors must account for the particular surface characteristics of the stop way and the variations in these characteristics with seasonal weather conditions (such as temperature, rain, snow and ice) within the established operational limits.

**5. Amendment to JAR 25.113 Take-off distance and take-off run to read as follows:**

- (a) Take-off distance on a dry runway is the greater of
  - (1) The horizontal distance along the take-off path from the start of the take-off to the point at which the aeroplane is 35 ft. above the take-off surface, as determined by a procedure consistent with JAR 25.111, or;
  - (2) 115% of the horizontal distance along the take-off path, with all engines operating, from the start of the take-off to the point at which the aeroplane is 35 ft above the take-off surface, as determined by a procedure consistent with JAR 25.111.
- (b) Take-off distance on a wet runway is the greater of
  - (1) The take-off distance on a dry runway determined in accordance with sub-paragraph 5.(a); or
  - (2) The horizontal distance along the take-off path from the start of the take-off to the point at which the aeroplane is 15 ft above the take-off surface, achieved in a manner consistent with the achievement of  $V_2$  before reaching 35 ft above take-off surface determined under JAR 25.111 for a wet runway.
- (c) If the take-off distance includes a clearway, the take-off run is greater of
  - (1) The horizontal distance along the take-off path from the start of the take-off to a point equivalent between the point at which VLOF is reached and the point at which the aeroplane is 35 ft above the take-off surface, as determined under JAR 25.111, except that,

Disclaimer – This document is not exhaustive and it will be updated gradually.



in the case of take-off on a wet runway, this distance need not be greater than the horizontal distance determined in accordance with sub-paragraphs 5.(b)(1) and 5.(b)(2); or  
(2) 115% of the horizontal distance along the take-off path with all engines operating, from the start of the take-off to a point equidistant between the point at which VLOF is reached and the point at which the aeroplane is 35 ft above the take-off surface, determined by a procedure consistent with JAR 25.111.

**6. Amendment to JAR 25.115 Take-off Flight Path sub-paragraph (a) to read as follows :**

(a) The take-off flight path shall be considered to begin 35 ft. above the lake-off surface at the end of the take-off distance determined in accordance with JAR 25.113 (a) or (b), as appropriate for the runway surface condition.

**7. Amendment to JAR 25.735 : Brakes**

**Amend JAR 25.735 (f) through (j) to read as follows :**

(f) The design landing brake kinetic energy capacity rating of each main wheel brake assembly shall be used during qualification testing of the brake to the applicable Joint Technical Standard Order (J-TSO) or an acceptable equivalent. This kinetic energy rating may not be less than the kinetic energy absorption requirements determined under either of the following methods:

1. The brake kinetic energy absorption requirements must be based on a rational analysis of the sequence of events expected during operational landings at maximum landing weight. This analysis must include conservative values of aeroplane speed at which the brakes are applied, braking coefficient of friction between tyres and runway, aerodynamic drag, propeller drag or power plant forward thrust and (if more critical) the most adverse single engine or propeller malfunction.
2. Instead of a rational analysis, the kinetic energy absorption requirements for each main wheel-brake assembly may be derived from the following formula, which assumes an equal distribution of braking between main wheels:

$$KE = \frac{0.0443WV^2}{N}$$

Where

**K** = kinetic energy per wheel (ft. lb.);  
**W** = design landing weight (lb);  
**V** = aeroplane speed in knots. V must not be less than V<sub>SO</sub>, the power off stalling of the aeroplane at sea-level, at the design landing weight, and in the landing configuration; and  
**N** = number of main wheels with brakes.

The formula must be modified in case of unequal braking distributions.

(g) In the landing case the minimum stalling speed rating of each main wheel brake assembly (that is, the initial speed used in the dynamometer tests) may not be more than the aeroplane speed used in the determination of kinetic energy in accordance with sub-paragraph (f) of this paragraph, assuming that the test procedures for wheel-brake assemblies involve a specified rate of deceleration, and, therefore for the same amount of kinetic energy, the rate

Disclaimer – This document is not exhaustive and it will be updated gradually.





of energy absorption (the power absorbing ability of the brake) varies inversely with the initial speed.

(h) The rejected take-off brake kinetic capacity rating of each main wheel-brake assembly that is at the fully worn limit of its allowable brake wear range shall be used during qualification testing of the brake to the applicable Joint Technical Standard Order (J-TSO) or an acceptable equivalent. This kinetic energy rating may not be less than the kinetic energy absorption requirements determined under either of the following methods:

1. The brake kinetic energy absorption requirements must be based on a rational analysis of the sequence of events expected during an accelerate-stop manoeuvre. This analysis must include conservative values of aeroplane speed at which the brakes are applied, braking coefficient of friction between tyres and runway, aerodynamic drag, propeller drag or power plant forward thrust and (if more critical) the most adverse single engine or propeller malfunction.
2. Instead of rational analysis, the kinetic energy absorption requirements for each main wheel-brake assembly may be derived from the following formula, which assumes an equal distribution of braking between main wheels;

$$KE = \frac{0.0443WV^2}{N}$$

Where

**KE** = kinetic energy per wheel (ft. lb.);  
**W** = design landing weight (lb.);  
and W and V are the most critical combination of weight and speed.

The formula must be modified in cases of designed unequal braking distribution.

(i) In addition, a flight test demonstration of the maximum kinetic energy rejected take-off shall be conducted with not more than 10% of the allowable brake wear range remaining;

(j) For each power-operated brake system incorporating an accumulator, the flight crew must be provided with an indication that adequate accumulator pressure is available.

**8. Amendment to JAR 25 x 1591 Supplementary performance information: to read as follows:**

8.1 Delete the words "wet and" on the 6<sup>th</sup> line of sub-paragraph (a).

8.2 Delete "wet/" from the 3<sup>rd</sup> and 6<sup>th</sup> lines of sub-paragraph (b).

8.3 Delete sub-paragraph (c)(1) and combine the introduction to subparagraph (c) with (c)(2) to read as follows:

(c) Supplementary performance information for runways contaminated with standing water, slush, loose snow, compacted snow or ice must be furnished. Information on the effect of runway contaminants on the expected performance of the aeroplane during take-off and landing on hard-surfaced runways must be furnished. If it appears in the Aeroplane Flight Manual, this information must be segregated, identified as guidance material and clearly

Disclaimer – This document is not exhaustive and it will be updated gradually.





distinguished from the additional operating limitations of JAR 25.1533 and the performance information of JAR 25.1587.

8.4 Amend sub-paragraph (d) to read as follows:

(d) The information required by sub-paragraph (a) of this paragraph may be established by calculation or by testing.

**9. Amendments to AMJ 25x1591 : to read as follows :**

9.1 Delete the words "for Take-off from Wet Runways and" from the title.

9.2 Delete the words "take-off performance information for wet runways and" from the 2<sup>nd</sup> line of paragraph 1.

9.3 Delete the opening words of sub-paragraph 3.1 "Take-off performance information for wet runways and".

9.4 Delete the whole of sub-paragraph 3.2.

9.5 Delete "wet/" from the 3<sup>rd</sup> line of sub-paragraph 6a.

### Acronyms and Abbreviations

<b>JAR</b>	Joint Aviation Regulation
<b>AMJ</b>	Advisory Material Joint
<b>FAR</b>	Federal Aviation Regulations
<b>NPA</b>	Notice of Proposed Amendment
<b>J-TSO</b>	Joint Technical Standard Order
<b>LOF</b>	Lift Off Speed

Disclaimer – This document is not exhaustive and it will be updated gradually.



## F-126: FLIGHT RECORDERS INCLUDING DATA LINK RECORDING

<b>SPECIAL CONDITION</b>	<b>F-126: Flight Recorders including Data Link Recording</b>
APPLICABILITY:	Post TC A330 / A340
REQUIREMENTS:	JAR 25.1301, 25.1457, 25.1459
ISSUE:	2 dated 26/06/2013

### Special condition summary

#### BACKGROUND

Commission Regulation (EC) N°29/2009, laying down requirements on the data link services for the Single European Sky, requires certain aircraft operating in designated airspace to be equipped with systems capable of providing Datalink Services (DLS), with the intention to augment or replace voice communications. For new aircraft, the requirements of EC 29/2009 apply from January 1<sup>st</sup> 2011.

In addition CAT.IDE.A.195 of Commission Regulation (EU) 965/2012, proposes new operational requirements for recording of data link communications, including but not limited to the required data link services identified in Annex II to European Commission Regulation EC N°29/2009.

#### *Effectivity:*

SC F-126 is applicable for all European operators operating a/c for which the Individual Certificate of Airworthiness is first issued on or after April 8, 2014 (aligned with EU OPS CAT.IDE.A.195). SC F-126 is applicable for all a/c for which the individual certificate of airworthiness is first issued on or after 1 January 2016 (aligned with ICAO Annex 6 Part I paragraph 6.3.3), except for US operators that operate under FAR121 and FAR 125.

The above mentioned regulations cover airspace and operational requirements but reveal a loophole which would result in aircraft equipped with the capability to provide DLS, not being required to record the DLS messages. The intent of JAR 25.1457 was to allow accident investigators to have as far as practicable a recording of all communications received or sent by each crew member. With the introduction of data link technology, much of the information which was previously transmitted by voice communications will be replaced by data link messages. With the requirement to provide DLS capability but no requirement to record the data link communication, the original intent of JAR 25.1457 would be jeopardized, making it more difficult for accident investigators to perform their tasks

#### SPECIAL CONDITION

The flight recorder (Cockpit Voice recorder or Flight Data Recorder) shall record:

- (a) Data Link communications related to air traffic services (ATS communications\*) to and from the aeroplane.

Disclaimer – This document is not exhaustive and it will be updated gradually.



- (b) All messages whereby the flight path of the aircraft is authorized, directed or controlled and which are relayed over a digital data link rather than by voice communication.
- (c) The minimum recording duration shall be equal to the duration of the Cockpit Voice Recorder and the recorded data shall be time correlated to the recorded cockpit audio.
- (d) To enable an aircraft operator to meet the intent of current EU OPS 1.160 (a)(4)(ii) Commission Regulation (EU) 965/2012 (CAT.IDE.A.195(b)), information shall be provided explaining how the recorded data can be converted back to the format of the original data link messages in order to determine an accurate sequence of events for the aircraft and the cockpit operation.

\*ATS communications (ATSC) are defined by ICAO as communications related to air traffic services including air traffic control, aeronautical and meteorological information, position reporting and services related to safety and regularity of flight.

### Acronyms and Abbreviations

<b>ATS</b>	Air Traffic Service
<b>ATSC</b>	Air Traffic Service Communications
<b>SC</b>	Special Condition
<b>DLS</b>	Data Link Service
<b>EASA</b>	European Aviation Safety Agency
<b>ICAO</b>	International Civil Aviation Organization
<b>JAR</b>	Joint Aviation Regulation

Disclaimer – This document is not exhaustive and it will be updated gradually.



## F-128: MINIMUM MASS FLOW OF SUPPLEMENTAL OXYGEN

<b>EQUIVALENT SAFETY FINDING</b>	<b>F-128: Minimum Mass Flow of Supplemental Oxygen</b>
APPLICABILITY:	A330/A340
REQUIREMENTS:	JAR 25.1443(c)
ISSUE:	1 dated 04/11/2014

### Equivalent Safety Findings summary

## BACKGROUND

Current airworthiness requirements of JAR 25.1443 (c) and associated standards of TSO C64a/SAE AS 8025 focus on the substantiation of the mean tracheal oxygen partial pressure, which is based on the existing oxygen dispensing technology.

Alternatively it is possible to verify the hypoxia protection capability of oxygen equipment by using the blood oxygenation level instead of the mean tracheal oxygen partial pressure. The ESF approach is in more detail specified below.

## EQUIVALENT SAFETY FINDING

### Minimum Mass Flow of Supplemental Oxygen

In lieu of the airworthiness requirements of JAR 25.1443(c) and associated standards of TSO C64a/SAE AS 8025, the following compliance method is considered acceptable:

For passengers and cabin crew members, it shall be shown, that the passenger oxygen system provides an equivalent level of protection from hypoxia as detailed below:

- (1) Between 10,000 ft and 18,500 ft cabin pressure altitude, the supplemental oxygen system for the passenger and cabin crew shall provide a blood oxygenation level that is equivalent with the blood oxygenation level reached at 10,000 ft cabin pressure altitude when breathing standard air. Breathing standard air at 10,000 ft cabin pressure altitude provides a mean tracheal oxygen partial pressure of 100 mmHg as required by JAR 25.1443(c).
- (2) Between 18,500 ft and 40,000 ft cabin pressure altitude, the supplemental oxygen system for the passenger and cabin crew shall provide a blood oxygenation level that is equivalent with the blood oxygenation level reached at 14,000 ft cabin pressure altitude when breathing standard air. Breathing standard air at 14,000 ft cabin pressure altitude provides a mean tracheal oxygen partial pressure of 83.8 mmHg as required by JAR 25.1443(c).

## Acronyms and Abbreviations

<b>JAR</b>	Joint Aviation Regulation
<b>TSO</b>	Technical Standard Order
<b>SAE</b>	Society of Automotive Engineers

Disclaimer – This document is not exhaustive and it will be updated gradually.



## **F-129: CREW DETERMINATION OF QUANTITY OF OXYGEN IN PASSENGER OXYGEN SYSTEM**

<b>EQUIVALENT SAFETY FINDING</b>	<b>F-129: Crew Determination of Quantity of Oxygen in Passenger Oxygen System</b>
APPLICABILITY:	A330/A340
REQUIREMENTS:	JAR 25.1441(c),
ISSUE:	1 dated 05/11/2014

### **Equivalent Safety Findings summary**

#### **BACKGROUND**

According to FAA AD 2011-04-09 all chemical oxygen generators installed within lavatories had to be removed or deactivated due to security reasons. All aircraft under FAA registration and operating under 14 CFR part 129 are affected, and some non-US registered aircraft were modified following requests of operator's local Authorities. The affected A/C are currently operated without any supplementary oxygen supply in the lavatories. AD 2012-NM-004-AD now require to install a supplement oxygen system till September 2015 that meets the new applicable sections of parts 25 and 121 of the Federal Aviation Regulations.

The major mods 203608/203609 defines new type II oxygen container based on a gaseous oxygen source 22 minutes/15 minutes to cover the AD 2012-NM-004-AD. The oxygen container will have the same dimensions and interfaces (electrical and mechanical) as current type II oxygen containers. For those small, one-time use gaseous oxygen bottles located in the lavatories, no means will be incorporated to inform the crew of the quantity of oxygen available in each source of supply. As design, the system will not meet the EASA Certification Specification 25.1441 (c) which requires a means to allow the crew to readily determine, during flight, the quantity of oxygen available in each oxygen supply source.

#### **EQUIVALENT SAFETY FINDINGS**

In lieu of the airworthiness requirements of JAR 25.1441(c), the following is considered acceptable if substantiated following the compliance method as described in further below:

If the oxygen source is a lifetime sealed oxygen high-pressure cylinder, the oxygen source can be considered as full oxygen capacity provided the oxygen quantity has not depleted since the date of manufacture.

- 1) A detailed description of the design details must be provided to describe the compensating features which provide an equivalent level of safety.
- 2) The oxygen supply source is designed and tested to ensure that it will retain its required quantity of oxygen or chemicals throughout its expected life limit under foreseeable operating conditions.

Disclaimer – This document is not exhaustive and it will be updated gradually.



- 
- 3) A means is provided for maintenance to readily determine when oxygen is no longer available in the supply source due to inadvertent activation.
  - 4) The life limit of the oxygen supply source is established by test and analysis.
  - 5) Each oxygen supply source is labeled such that the expiration date can be easily determined by maintenance.
  - 6) Airbus defines maintenance and inspection procedures in the maintenance planning documents to ensure that the oxygen supply source
    - a. that are discharged are removed from the aeroplane,
    - b. are not installed on the aeroplane past their expiration date.
  - 7) Each oxygen supply source does not supply oxygen to more than six oxygen masks.

### Acronyms and Abbreviations

<b>AD</b>	Airworthiness Directives
<b>CFR</b>	Code of Federal Regulation
<b>AD</b>	Airworthiness Directives

Disclaimer – This document is not exhaustive and it will be updated gradually.



## **F-131: FLIGHT INSTRUMENT EXTERNAL PROBES – QUALIFICATION IN ICING CONDITIONS**

<b>SPECIAL CONDITION</b>	<b>F-131: Flight Instrument External Probes – Qualification in Icing Conditions</b>
APPLICABILITY:	A330 / A340
REQUIREMENTS:	CS 25.1309, CS 25.1323(h), CS 25.1323(i), CS 25.1325(b), CS 25.1419, CS 25.1529
ISSUE:	Issue 3 dated 05 April 2016

### **Special Condition summary**

#### **BACKGROUND**

Icing conditions related contamination of Flight Instrument External Probes is currently regulated through requirement CS 25.1323(h) and CS 25.1323 (i) for airspeed indicating system and CS 25.1325(b) for static pressure system.

CS 25 Appendix C conditions and ETSO C16a / ETSO C54 do not include mixed phase and ice crystal icing conditions and the operating rules do not prohibit operations in such environment.

In consideration of the above requirement limitations, EASA, through the use of the CS advisory materials, has extended the icing conditions of CS 25 Appendix C to include mixed phase and ice crystal conditions.

In accordance with IR 21, § 21A.16B, it is the Agency position that the related airworthiness code does not contain adequate or appropriate safety standards regarding the installation of probes for new environmental conditions on Long Range family aircraft. Therefore the Special Condition detailed in Appendix to this CRI shall be met for the new probes.

#### **SPECIAL CONDITION**

##### **1. Replace CS 25.1323(i), AMC 25.1323(i) by SC 2 and respective AMC's**

##### **2. Flight Instrument External Probes Heating Systems**

*Each flight instrument external probes systems, including, but not necessarily limited to, pitot tubes, pitot-static tubes, static probes, angle of attack sensors, side slip vanes, and temperature probes, must be heated or have an equivalent means of preventing malfunction in the heavy rain conditions defined in table of this paragraph, in the icing conditions as defined in CS 25 Appendices C and in mixed phase / ice crystal conditions as defined in Appendix 1 of this Special Condition*

Disclaimer – This document is not exhaustive and it will be updated gradually.



*Rain test conditions*

Altitude Range		Liquid Water Content	Horizontal Extent		Droplet MVD
(ft)	(m)	(g/m <sup>3</sup> )	(km)	(NM)	(µm)
0 to 10000	0 to 3000	1	100	50	500 to 2000
		6	5	3	
		15	1	0.5	

**Mixed Phase and Ice Crystal Icing Envelope (Deep Convective Clouds)**

**References**

1. THE ANALYSIS OF MEASUREMENTS OF FREE ICE AND ICE/WATER CONCENTRATIONS IN THE ATMOSPHERE OF THE EQUATORIAL ZONE, IAN I. MCNAUGHTON, B.SC., DIP. R.T.C., ROYAL AIRCRAFT ESTABLISHMENT (FARNBOROUGH) TECHNICAL NOTE NO: MECH. ENG. 283
2. SNOW AND ICE PARTICLE SIZES AND MASS CONCENTRATIONS AT ALTITUDES UP TO 9 KM ( 30,000 FT), R. K. JECK, DOT/FAA/AR-97/66, AUGUST, 1998.
3. CLOUD MICROPHYSICAL MEASUREMENTS IN THUNDERSTORM OUTFLOW REGIONS DURING ALLIED/BAE 1997 FLIGHT TRIALS, STRAPP, J.W., P. CHOW, M. MALTBY, A.D. BEZER, A. KOROLEV, I. STOMBERG, AND J. HALLETT, *37TH AIAA AEROSPACE SCIENCES MEETING AND EXHIBIT*, JAN. 11-14, 1999, RENO, NV. AIAA 99-0498.
4. ARAC EHWG PROPOSED APPENDIX D TO 14 CFR PART 33

Ice crystal conditions associated with convective storm cloud formations exist within the CS 25 Appendix C Intermittent Maximum Icing envelope (including the extension to -40 deg C) and the Mil Standard 310 Hot Day envelope. This ice crystal icing envelope is depicted in the Figure D-1.

Disclaimer – This document is not exhaustive and it will be updated gradually.





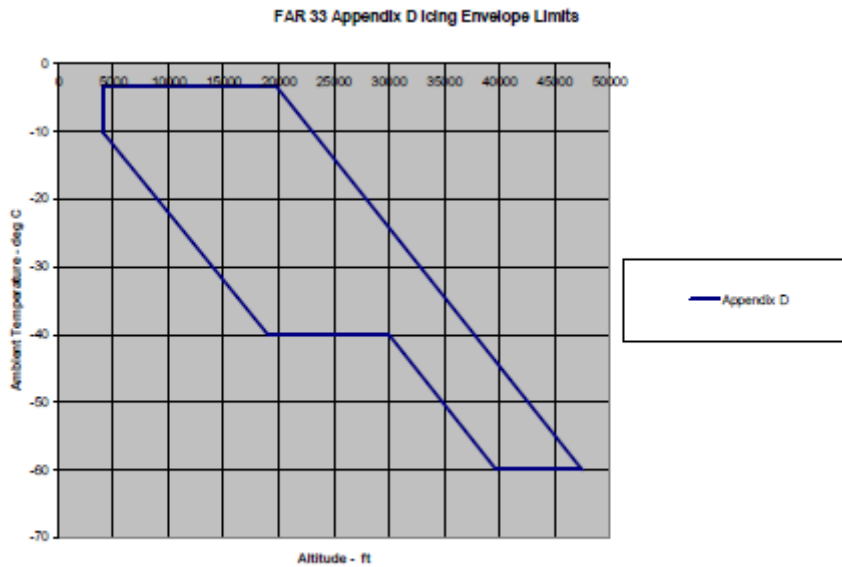

Figure D-1 Convective Cloud Ice Crystal Envelope

Within the envelope, total water content (TWC) in gms/m<sup>3</sup> have been assessed based upon the adiabatic lapse defined by the convective rise of 90% relative humidity air from sea level to higher altitudes and scaled by a factor of 0.65 to a standard cloud length of 17.4 nautical miles. TWC is displayed for this distance over a range of ambient temperature within the boundaries of the ice crystal envelope in Figure D-2.

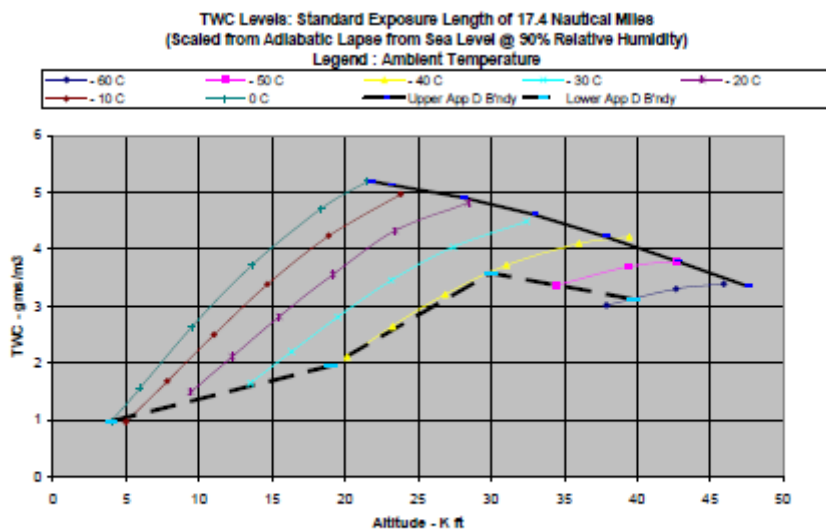

Figure D-2 Total Water Content

Ice crystal size median mass dimension (MMD) range is 50 - 200 microns (equivalent spherical size) based upon measurements near convective storm cores.

The TWC can be treated as completely glaciated except as noted in the Table D-1.

Disclaimer – This document is not exhaustive and it will be updated gradually.



Temperature Range – deg C	Horizontal Cloud Length	LWC – gm/m3
0 to -20	</= 50 miles	</=1.0
0 to -20	Indefinite	</=0.5
< -20		0

Table D-1 Supercooled Liquid Portion of TWC

The TWC levels displayed in Figure D-2 represent TWC values for a standard exposure distance (horizontal cloud length) of 17.4 nautical miles that must be adjusted with length of icing exposure. The assessment from data measurements in References 1 supports the reduction factor with exposure length shown in Figure D-3.

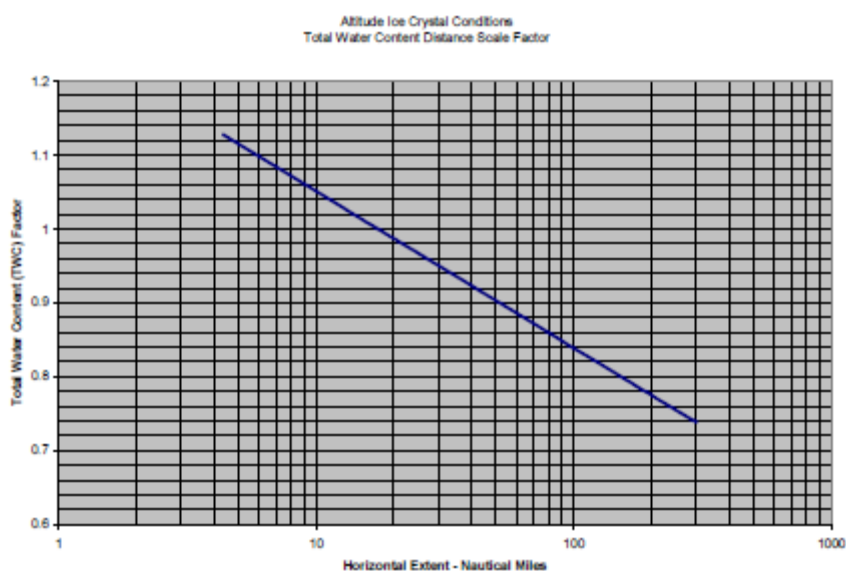

Figure D-3 Exposure Length Influence on TWC

## Acronyms and Abbreviations

<b>JAR</b>	Joint Aviation Regulation
<b>AC</b>	Advisory Circular
<b>AMC</b>	Acceptable Means of Compliance
<b>ARAC</b>	Aviation Rulemaking Advisory Committee
<b>IPHWG</b>	Ice Protection Harmonisation Working Group

Disclaimer – This document is not exhaustive and it will be updated gradually.



**F-137: SECURITY PROTECTION OF AIRCRAFT SYSTEMS AND NETWORKS**

<b>SPECIAL CONDITION</b>	<b>F-137: Security protection of Aircraft systems and networks</b>
APPLICABILITY:	A330 / A340
REQUIREMENTS:	JAR 25.1309 Change 13
ISSUE:	17 May 2018

**Special condition Summary**

**BACKGROUND:**

JAR/CS 25 does not address Cyber Security and AMJ/AMC 25 1309 explicitly exclude act of sabotage from the list of events to be addressed during the safety assessment.

Airbus intends to install new systems with connectivity to non-trusted services in the Airbus Long Range aircraft which may introduce the potential for unauthorized electronic access to Aircraft Systems. They may introduce new threats to the safety of the aircraft by the exploitation of potential known and unknown vulnerabilities with the aim to intentionally alter the integrity and availability of critical data, aircraft networks, systems or databases.

Therefore, this Special Condition (SC) has been established to address the issue.

**SPECIAL CONDITION**

- a) The applicant shall ensure security protection of the aircraft systems from unauthorized electronic access through the system introducing connectivity to non-trusted services, if corruption of these systems (including hardware, software, data) by an inadvertent or intentional attack would impair safety, and
- b) The applicant shall ensure that the security threats to the aircraft systems, including those possibly caused by maintenance activity on the system having connectivity to non-trusted services or by any unprotected equipment/devices connected to this system, are identified, assessed and risk mitigation strategies are implemented to protect the aircraft systems from all adverse impacts on safety, and
- c) When required by paragraph (a), the applicant shall make available procedures and instructions for continued airworthiness to ensure security protections are maintained.

Disclaimer – This document is not exhaustive and it will be updated gradually.



---

**Acronyms and Abbreviations**

AMC	Acceptable Means of Compliance
CRI	Certification Review Item
CS	Certification Specification
EASA	European Aviation Safety Agency
ED	EUROCAE Document
FLS	Field Loadable Software
RTCA	Radio Technical Commission for Aeronautics
SC	Special Condition

Disclaimer – This document is not exhaustive and it will be updated gradually.



**F-GEN-01: INSTALLATION OF NON-RECHARGEABLE LITHIUM BATTERY**

<b>SPECIAL CONDITION</b>	<b>F-GEN-01: Installation of non-rechargeable lithium battery</b>
APPLICABILITY:	A330 / A340
REQUIREMENTS:	CS 25.601, 25.863, 25.869, 25.1301, 25.1309, 25.1353(c), 25.1529, 25.1360(b)
ISSUE:	1 dated 04 Mar 2019

**Special Condition summary**

**BACKGROUND**

Non-rechargeable lithium batteries and battery systems have certain failure, operational, and maintenance characteristics that can present hazards that are not adequately identified and addressed through traditional compliance methods.

A Special Condition is needed to establish the means by which known or anticipated hazards associated with non-rechargeable lithium batteries and battery systems shall be addressed.

**SPECIAL CONDITION**

In lieu of the requirements of CS 25.1353(c)(1) through (c)(4), non-rechargeable lithium batteries and battery installations must comply with the following special conditions:

1. Be designed so that safe cell temperatures and pressures are maintained under all foreseeable operating conditions to preclude fire and explosion.
2. Be designed to preclude the occurrence of self-sustaining, uncontrolled increases in temperature or pressure.
3. Not emit explosive or toxic gases in normal operation, or as a result of its failure, that may accumulate in hazardous quantities within the airplane.
4. Must meet the requirements of CS 25.863(a) through (d).
5. Not damage surrounding structure or adjacent systems, equipment or electrical wiring of the airplane from corrosive fluids or gases that may escape and that may cause a major or more severe failure condition.
6. Have provisions to prevent any hazardous effect on airplane structure or essential systems caused by the maximum amount of heat it can generate due to any failure of it or its individual cells.
7. Have a means to detect its failure and alert the flight crew in case its failure affects safe operation of the aircraft.

Disclaimer – This document is not exhaustive and it will be updated gradually.



8. Have a means for the flight crew or maintenance personnel to determine the battery charge state if its function is required for safe operation of the airplane.

Note 1: A battery system consists of the battery and any protective, monitoring and alerting circuitry or hardware inside or outside of the battery. It also includes vents (where necessary) and packaging. For the purpose of this special condition, a battery and battery system are referred to as a battery.

Note 2: These Special Conditions apply in lieu of 25.1353(c)(1) through (c)(4) to non-rechargeable lithium battery and battery installations as follows:

- All new, changed or relocated non-rechargeable lithium battery and battery installations
- All existing non-rechargeable lithium battery installations affected by a design change, even if the battery or battery installation itself does not change (ex: change in ambient temperature or pressure environment in which the battery operates, change on the electrical load on a battery).:

Section 25.1353(c)(1) through (c)(4) will remain in effect for other battery installations.

Note 3: For very small non-rechargeable lithium batteries (equal or less than 2 Watt-hour of energy), an acceptable MoC with this Special Conditions is showing these batteries compliant with Underwriters Laboratories (UL) 1642 or UL 2054.

Note 4: For the purpose of SCs 7 and 8, “safe operation of the airplane” is defined as continued safe flight and landing following failures or other non-normal conditions. The following are examples of devices with batteries that are not required for continued safe flight and landing of the airplane: emergency locator transmitters, underwater locator beacons, seat belt air bag initiators and flashlights. A backup flight instrument with a non-rechargeable lithium battery is an example that would be required for safe operation of the airplane.

Note 5: Minimum Operational Performance Standards (MOPS) for Non-Rechargeable Lithium Batteries DO-227A + risk assessment at A/C level (limited to SC 3, 4, 5 & 6) is an acceptable MoC to the SC's 1 to 6. Alternative Means of Compliance can be proposed by the applicant to show compliance with the SC's and agreed by EASA in a case by case basis.

Disclaimer – This document is not exhaustive and it will be updated gradually.



## F-1001: STALLING AND SCHEDULED OPERATING SPEEDS

<b>SPECIAL CONDITION</b>	<b>F-1001: Stalling and scheduled operating speeds</b>
APPLICABILITY:	A340-500/-600
REQUIREMENTS:	JAR 25.103, 25.107, 25.121, 25.125, 25.201, 25.203, 25.205, 25.207
ISSUE:	2 dated 18/05/2000

### Special Condition summary

## BACKGROUND

The A340-500/-600 aircraft models are equipped with a low speed protection system provided against stall a protection that cannot be overridden by the pilot.

The requirement of JAR 25 must therefore be adapted to consider this stall protection function.

## SPECIAL CONDITION

### 1- Definitions

This Special Condition is concerned with novel features of the A340 aircraft models and uses terminology that does not appear in JAR 25.

The following definitions shall apply:

- **High incidence protection system:** A system that operates directly and automatically on the aeroplane's flying controls to limit the maximum incidence that can be attained to a value below that at which an aerodynamic stall would occur.
- **Alpha-floor system:** A system that automatically increases thrust on the operating engines when incidence increases through a particular value.
- **Alpha-limit:** The maximum steady incidence at which the aeroplane stabilises with the high incidence protection system operating and the longitudinal control held on its aft stop.
- **V<sub>min</sub>:** The minimum steady flight speed in the aeroplane configuration under consideration with the high incidence protection system operating. See section 3 of this Special Condition.
- **V<sub>min1g</sub>:** V<sub>min</sub> corrected to 1 g conditions. See section 3 of this Special Condition.
- **V<sub>s1g</sub>:** The minimum speed in the configuration under consideration at which the aeroplane can develop a lift equal to the weight the aeroplane with engines set to idle thrust. This speed may be demonstrated with the high incidence system adjusted to permit a higher incidence to be achieved, than is possible with the normal production system.

### 2- Capability and Reliability of the High Incidence protection System.

Disclaimer – This document is not exhaustive and it will be updated gradually.



Those paragraphs of JAR 25 quoted in reference may be amended in accordance with Special Condition provided that acceptable capability and reliability of the high incidence protection system can be established by flight test, simulation, and analysis as appropriate. The capability and reliability required are as follows:

- 1- It shall not be possible during pilot induced manoeuvres to encounter a stall and handling characteristics shall be acceptable, as required by section 6 of this Special Condition.
- 2- The aeroplane shall be protected against stalling due to the effects of windshears and gusts at low speeds as required by section 7 of this Special Condition.
- 3- The ability of the high incidence protection system to accommodate any reduction in stalling incidence resulting from residual ice must be verified.
- 4- The reliability of the system and the effects of failures must be acceptable in accordance with JAR 25.1309.

### 3- Minimum Steady Flight Speed and One g Stall Speed

Delete existing JAR 25.103 and replace as follows:

JAR 25.103: Minimum steady flight speed and one g stall speed

- (a) The minimum steady flight speed,  $V_{min}$ , must be determined with:
  - (1) The high incidence protection system operating normally.
  - (2) Idle thrust and alpha-floor system inhibited.
  - (3) All combinations of flap settings and landing gear position for which  $V_{min}$  is required to be determined.
  - (4) The weight used when  $V_{s1g}$  is being used as a factor to determine compliance with a required performance standard;
  - (5) The most unfavourable centre of gravity allowable; and
  - (6) The aeroplane trimmed for straight flight at a speed achievable by the automatic trim system.
- (b) The minimum steady flight speed is the final stabilised calibrated airspeed obtained when the aeroplane is decelerated at an entry rate not exceeding 1 knot per second until the longitudinal control is on its stop.
- (c) The one-g minimum steady flight speed,  $V_{min1g}$ , is the minimum calibrated airspeed at which the aeroplane can develop a lift force (normal to the flight path) equal to its weight, whilst at an angle of attack not greater than that at which the minimum steady flight speed of sub-paragraph (b) was determined.
- (d) The one-g stall speed,  $V_{s1g}$ , must be determined with:
  - (1) Idle thrust and Alpha-floor system inhibited;
  - (2) All combinations of flap settings and landing gear position for which  $V_{s1g}$  is required to be determined;

Disclaimer – This document is not exhaustive and it will be updated gradually.





- (3) The weight used when  $V_{s1g}$  is being used as a factor to determine compliance with a required performance standard;
- (4) The most unfavourable centre of gravity allowable; and
- (5) The aeroplane trimmed for straight flight at a speed achievable by the automatic trim system.

## 4- Scheduled operating speeds

### 4.1 Take off Speeds

Delete existing JAR 25.107(b) and replace as follows:

JAR 25.107(b):  $V_2$ , in terms of calibrated airspeed, may not be less than:

- (1)  $1.13 V_{s1g}$
- (2) 1.10 times  $V_{MC}$  established under JAR 25.149
- (3) A speed that provides the manoeuvre capability specified in paragraph 4.4

### 4.2 Climb one engine inoperative

In JAR 25.121(c) Final Take-off, amend "at not less than  $1.25 V_s$ ..." to read "...at not less than the greater of  $1.18 V_{s1g}$  and a speed that provides the manoeuvre capability specified in paragraph 4.4, with...".

### 4.3 Landing Speeds

In JAR 25.125 the value of  $V_{REF}$  used for landing performance determination must not be less than:

- (1)  $1.23 V_{s1g}$
- (2)  $V_{MCL}$  established under JAR 25-149(f), (See ACJ 25.125(a)(2))
- (3) A speed that provides the manoeuvre capability specified in paragraph 4.4

### 4.4 Manoeuvrability at operating speeds

The manoeuvring capabilities in a constant speed coordinated turn at forward center of gravity, as specified in the table below, must be free of stall warning (if any), or other characteristics which might interfere with normal manoeuvring.

Configuration	Speed	Manoeuvring bank angle in a coordinated turn	Thrust/Power setting
Take-off	$V_2$	30°	Asymmetric WAT-limited (1)
Take-off	$V_2+XX(2)$	40°	All engines climb (3)
En route	$V_{FTO}$	40°	Asymmetric WAT-limited (1)
Landing	$V_{REF}$	40°	Symmetric for -3° flight path angle

- (1) A combination of weight, altitude and temperature (WAT) such that the thrust or power setting produces the minimum climb gradient specified in JAR 25.121 for the flight condition.
- (2) Airspeed approved for all engines initial climb.
- (3) That thrust or power setting which, in the event of failure of the critical engine and without any crew action to adjust the thrust or power of the remaining engines, would result in the thrust or power specified for the take-off condition at  $V_2$ , or any lesser thrust or power setting that is used for all engines-operating initial climb.

Disclaimer – This document is not exhaustive and it will be updated gradually.



## 5- Stall Warning

### 5.1 Normal operation

If the conditions of paragraph 2 are satisfied, equivalent safety to the intent of JAR 25.207, Stall Warning, shall be considered to have been met without provision of an additional, unique warning device.

### 5.2 Failures cases

Following failures of the high incidence protection system, not shown to be extremely improbable, such that capability of the system no longer satisfies items 1, 2 and 3 of paragraph 2 stall warning must be provided in accordance with JAR 25.207(a) and (b).

## 6- Handling Characteristics at High Incidence

### 6.1 High Incidence Handling Demonstrations

Delete existing JAR 25.201 and replace as follows:

JAR 25.201: High incidence handling demonstration

- (a) Manoeuvres to the limit of the longitudinal control, in the nose up sense, must be demonstrated in straight flight and in 30° banked turns with:
- (1) The high incidence protection system operating normally.
  - (2) Initial power conditions of:
    - I: Power off
    - II: The power necessary to maintain level flight at  $1.5 V_{s1g}$ , where  $V_{s1g}$  corresponds to the one g stall speed with flaps in approach position, the landing gear retracted and maximum landing weight.
  - (3) Alpha-floor system operating normally unless more severe conditions are achieved with inhibited alpha floor.
  - (4) Flaps, landing gear and deceleration devices in any likely combination of positions
  - (5) Representative weights within the range for which certification is requested; and
  - (6) The aeroplane trimmed for straight flight at a speed achievable by the automatic trim system.
- (b) The following procedures must be used to show compliance with JAR 25.203. (\*)
- (1) Starting at a speed sufficiently above the minimum steady flight speed to ensure that a steady rate of speed reduction can be established, apply the longitudinal control so that the speed reduction does not exceed one knot per second until the control reaches the stop.
  - (2) The longitudinal control must be maintained at the stop until the aeroplane has reached a stabilised flight condition and must then be recovered by normal recovery techniques.
  - (3) The requirements for turning flight manoeuvre demonstrations must also be met with accelerated rates of entry to the incidence limit, up to the maximum rate achievable.
- (\*) as amended by this special condition

Disclaimer – This document is not exhaustive and it will be updated gradually.



## 6.2 Characteristics in High Incidence Manoeuvres

Delete existing JAR 25.203 and the associated ACJ.

Replace as follows:

JAR 25.203: Characteristics in High Incidence Manoeuvres.

- (a) Throughout manoeuvres with a rate of deceleration of not more than 1 knot per second, both in straight flight and in 30° banked turns, the aeroplane's characteristics shall be as follows:
- (1) There shall not be any abnormal nose-up pitching.
  - (2) There shall not be any uncommanded nose-down pitching, which would be indicative of stall. However reasonable attitude changes associated with stabilising the incidence at Alpha limit as the longitudinal control reaches the stop would be acceptable.
  - (3) There shall not be any uncommanded lateral or directional motion and the pilot must retain good lateral and directional control, by conventional use of the controls, throughout the manoeuvre.
  - (4) The aeroplane must not exhibit severe buffeting of a magnitude and severity that would act as a deterrent to completing the manoeuvre specified in JAR 25.201(a)\*.
- (\* ) As amended by this Special Condition
- (b) In manoeuvres with increased rates of deceleration some degradation of characteristics is acceptable, associated with a transient excursion beyond the stabilised Alpha-limit. However the aeroplane must not exhibit dangerous characteristics or characteristics that would deter the pilot from holding the longitudinal control on the stop for a period of time appropriate to the manoeuvre.
- (c) It must always be possible to reduce incidence by conventional use of the controls.
- (d) The rate at which the aeroplane can be manoeuvred from trim speeds associated with scheduled operating speeds such as  $V_2$  and  $V_{REF}$  up to Alpha-limit shall not be unduly damped or be significantly slower than can be achieved on conventionally controlled transport aeroplanes.

## 6.3 High Incidence Handling with the Critical Engine Inoperative

Revoked

## **7- Atmospheric Disturbances**

Operation of the high incidence protection system must not adversely affect aircraft control during expected levels of atmospheric disturbances, nor impede the application of recovery procedures in case of windshear.

## **8- Speeds Associated with Other Requirements**

Disclaimer – This document is not exhaustive and it will be updated gradually.



JAR 25 specifies requirements that have to be met at speeds quoted as factors of the stall speed  $V_S$ . For the A340 aircraft models  $V_S$  will be interpreted in each paragraph of the requirements according to the appendix.

## 9- Alpha floor

The Alpha-floor setting must be such that the aircraft can be flown at normal landing operational speeds and manoeuvred up to bank angles consistent with the flight phase without triggering Alpha-floor.

In addition there must be no alpha-floor triggering unless appropriate when aircraft is flown in usual operational manoeuvres and in turbulence.

## APPENDIX TO SPECIAL CONDITION F-1001

### 1- JAR 25.21:

Add the following paragraph 25.21(b):

- (b) The flying qualities will be evaluated at the most unfavourable CG position.

### 2- In lieu of JAR 25.119 paragraph (b)

(b) A climb speed which is:

- (1) not less than
  - i)  $1.08 V_{s1g}$  for aeroplanes with four engines on which the application of power results in significant reduction in stalling speed; or
  - ii)  $1.13 V_{s1g}$  for all other aeroplanes
- (2) not less than  $V_{MCL}$ ; and
- (3) not more than the greater of  $V_{REF}$  and  $V_{MCL}$

### 3- Replace JAR 25.121 paragraph (d) by:

(d) Discontinued approach. In a configuration in which  $V_{s1g}$  does not exceed 110% of the  $V_{s1g}$  for the related all-engines operating landing configuration, the steady gradient may not be less than 2.1% for two engines aeroplanes, and 2.7% for four engines aeroplanes with:

- (1) the critical engine inoperative, the remaining engines at the go-around thrust setting;
- (2) the maximum landing weight; and
- (3) a climb speed established in connexion with normal landing procedures; but not exceeding  $1.41 V_{s1g}$ .

### 4- Replace the speeds $V_S$ mentioned in the following JAR 25 requirements as follows:

JAR 25.145 (a)	$V_{min}$ in lieu of $V_S$
JAR 25.145 (b) (1)	$1.32 V_{s1g}$ in lieu of $1.4 V_{s1}$
JAR 25.145 (b) (4)	$1.32 V_{s1g}$ in lieu of $1.4 V_{s1}$
JAR 25.145 (b) (6)	$1.32 V_{s1g}$ in lieu of $1.4 V_{s1}$
	$V_{min}$ in lieu of $1.1 V_{s1}$

Disclaimer – This document is not exhaustive and it will be updated gradually.



JAR25.145 (c)	1.6 $V_{s1g}$ in lieu of 1.7 $V_{s1}$
JAR 25.147 (a)	1.13 $V_{s1g}$ in lieu of 1.2 $V_{s1}$
JAR 25.147 (a) (2)	1.3 $V_{s1g}$ in lieu of 1.4 $V_{s1}$
JAR 25.147 (c)	1.3 $V_{s1g}$ in lieu of 1.4 $V_{s1}$
JAR 25.147 (d)	1.3 $V_{s1g}$ in lieu of 1.4 $V_{s1}$
JAR 25.149 (c)	1.13 $V_{s1g}$ in lieu of 1.2 $V_{s1}$
JAR 25.161 (b)	1.3 $V_{s1g}$ in lieu of 1.4 $V_{s1}$
JAR 25.161 (c) (1)	1.3 $V_{s1g}$ in lieu of 1.4 $V_{s1}$
JAR 25.161 (c) (2)	1.3 $V_{s1g}$ in lieu of 1.4 $V_{s1}$
JAR 25.161 (c) (3)	1.3 $V_{s1g}$ in lieu of 1.4 $V_{s1}$
JAR 25.161 (d)	1.3 $V_{s1g}$ in lieu of 1.4 $V_{s1}$
JAR 25.175 (a)	not applicable, see SC F-1003
JAR 25.175 (d)	not applicable, see SC F-1003
JAR 25.177 (a)	1.13 $V_{s1g}$ in lieu of 1.2 $V_{s1}$
JAR25.177 (b)(1)	1.13 $V_{sg}$ to 1.23 $V_{s1g}$ in lieu of 1.2 $V_{s1}$ to 1.3 $V_{s1}$
JAR 25.177 (b) (2)	1.13 $V_{s1g}$ to 1.23 $V_{s1g}$ in lieu of 1.2 $V_{s1}$ to 1.3 $V_{s1}$
JAR25.177 (b)(3)	1.23 $V_{s1g}$ in lieu of 1.3 $V_{s1}$
JAR 25.181 (a)	1.13 $V_{s1g}$ in lieu of 1.2 $V_s$
JAR 25.233 (a)	replace 0.2 $V_{so}$ by 0.2 $V_{s1g}$
JAR 25.237	0.94 $V_{s1g}$ in lieu of $V_{so}$
JAR 25.735 (f) (2)	0.94 $V_{s1g}$ in lieu of $V_{so}$
JAR 25.773 (b)(1)(i)	1.5 $V_{s1g}$ in lieu of 1.6 $V_{s1}$
JAR25.1001 (c)(1)	.94 $V_{s1g}$ in lieu of $V_{s1}$
JAR 25.1001 (c) (3)	.94 $V_{s1g}$ in lieu of $V_{s1}$
JAR 25.1323(c) (1) (i)	.94 $V_{s1g}$ in lieu of $V_{s1}$
JAR 25.1323(c) (1) (ii)	.94 $V_{s1g}$ in lieu of $V_{so}$
JAR 25.1323 (c) (2)	"From 1.3 x 0.94 $V_{s1g}$ to $V_{min}$ " in lieu of "1.3 $V_s$ to stall warning speed" and "speeds below $V_{min}$ " in lieu of "speeds below stall warning"
JAR 25.1325(e)	replace 1.3 $V_{s0}$ by 1.3 x .94 $V_{s1g}$ and 1.8 $V_{s1}$ by 1.8 x .94 $V_{s1g}$

### Acronyms and Abbreviations

<b>JAR</b>	Joint Aviation Regulation
<b>ACJ</b>	Advisory Circular Joint

Disclaimer – This document is not exhaustive and it will be updated gradually.



## F-1003: STATIC LONGITUDINAL STABILITY AND LOW ENERGY AWARENESS

<b>SPECIAL CONDITION</b>	<b>F-1003: Static Longitudinal Stability and Low energy awareness</b>
APPLICABILITY:	A340-500/-600
REQUIREMENTS:	JAR 25.171, 25.173, 25.175,
ISSUE:	4 dated 08/12/2000

### Special condition summary

#### BACKGROUND

The A340-500/-600 longitudinal control laws provide a neutral stability within the normal flight envelope. Therefore, the aircraft design does not literally comply with the static longitudinal stability requirements of JAR 25.171, 25.173, and 25.175. These requirements must consequently be replaced by a special condition.

In addition, past experience on aircraft fitted with a flight control system providing a neutral longitudinal stability shows there is insufficient feedback cue of excursion below operational speeds. Protection systems associated with these laws secure the aircraft against stall but are not sufficient to prevent low speed excursions because they intervene far below normal operational speeds, and until intervention, there are no stability cues since the aircraft remains trimmed. Additionally, the pitching moment due to thrust variation is reduced by the flight control laws. Recovery from a low speed excursion may become hazardous when the low speed situation is associated with a low altitude and with the engines at idle, i.e. when there is a low energy situation. These low energy situations must be avoided and therefore the pilots must be given adequate cues when approaching such situations.

#### SPECIAL CONDITION

The aircraft shall be shown to have suitable stability in any condition normally encountered in service, including the effects of atmospheric disturbances.

The aircraft, fitted with flight control laws presenting neutral longitudinal stability significantly below the normal operating speeds, must provide adequate awareness to the pilot of a low energy state.

#### Acronyms and Abbreviations

<b>JAR</b>	Joint Aviation Regulation
------------	---------------------------

Disclaimer – This document is not exhaustive and it will be updated gradually.



## F-1008: ACCELERATE STOP DISTANCES

SPECIAL CONDITION	F-1008: Accelerate stop distances
APPLICABILITY:	A340-500/-600
REQUIREMENTS:	JAR 1.1, JAR 1.2, JAR 25.101, 25.105, 25.107, 25.109, 25.113, 25.115, 25.735, 25.1533, 25X1591
ISSUE:	2 dated 17/11/2000

### Special condition summary

## BACKGROUND

The applicable JAR-25 for A340-500/-600 Type Certification includes the amendments introduced by FAR 25 amendment 42 / JAR 25 change 5.

These requirements have been the subject of a review by the aviation community since the last ten years in order to establish new standards.

NPA 25B,D,G-244 "Accelerate-stop distances and related performance matters" provides alternative JAR standards for establishing an acceptable level of safety in RTO and related performance matters.

These standards would not only be applicable to new types but also derivatives and in some areas to in-service aeroplanes.

Airbus elected to comply with NPA 25B,D,G-244.

## SPECIAL CONDITION

### 1. Amendments to JAR 1

1.1 Amend the definition of  $V_1$  in JAR 1.2 as follows:

" $V_1$ " means the maximum speed in the take-off at which the pilot must take the first action (e.g. apply brakes, reduce thrust, deploy speed brakes) to stop the aeroplane within the accelerate-stop distance.  $V_1$  also means the minimum speed in the take-off, following a failure of the critical engine at  $V_{EF}$ , at which the pilot can continue the take-off and achieve the required height above the take-off surface within the take-off distance.

1.2 Add a definition of the abbreviation  $V_{EF}$  to JAR 1.2 as follows :

" $V_{EF}$  means the speed at which the critical engine is assumed to fail during take-off."

### 2. Amendments to JAR 25

2.1 Amendment to JAR 25.101: General

Add a new sub-paragraph (i) to read as follows:

Disclaimer – This document is not exhaustive and it will be updated gradually.





- (i) The accelerate-stop and landing distances prescribed in JAR 25.109 and 25.125, respectively, must be determined with all the aeroplane wheel brake assemblies at the fully worn limit of their allowable wear range. (See ACJ 25.101(i)).

## 2.2 Amendment to JAR 25.105: Take-Off

Amend sub-paragraph (c) to read as follows:

- (c) The take-off data must be based on:
  - (1) Smooth, dry and wet, hard-surfaced runways; and
  - (2) At the option of the applicant, grooved or porous friction course wet, hard surfaced runways.

## 2.3 Amendment to JAR 25.107: Take-off speeds

Amend sub-paragraph (a)(2) to read as follows :

- (2)  $V_1$ , in terms of calibrated airspeed, is selected by the applicant; however,  $V_1$  may not be less than  $V_{EF}$  plus the speed gained with the critical engine inoperative during the time interval between the instant at which the critical engine is failed, and the instant at which the pilot recognizes and reacts to the engine failure, as indicated by the pilot's initiation of the first action (e.g. applying brakes, reducing thrust, deploying speed brakes) to stop the aeroplane during accelerate-stop tests.

## 2.4 Amendment to JAR 25.109: Accelerate-stop distances

Amend sub-paragraph (a), add new sub-paragraphs (b), (c) and (d), amend existing subparagraph (b) and re-designate it as (e), add a new sub-paragraph (f), re-designate existing sub-paragraph (c) as (g), amend existing sub-paragraph (d) and re-designate it as (h) and add a new sub-paragraph (i), JAR 25.109 thus reads as follows:

JAR 25.109 Accelerate-stop distances.

- (a) (See ACJ 25.109 (a)). The accelerate-stop distance on a dry runway is the greater of the following distances :
  - (1) The sum of the distances necessary to:
    - (i) Accelerate the aeroplane from a standing start with all engines operating to  $V_{EF}$  for take-off from a dry runway;
    - (ii) Allow the aeroplane to accelerate from  $V_{EF}$  to the highest speed reached during the rejected take-off, assuming the critical engine fails at  $V_{EF}$  and the pilot takes the first action to reject the take-off at the  $V_1$  from a dry runway; and
    - (iii) Come to a full stop on a dry runway from the speed reached as prescribed in subparagraph (a)(1)(ii) of this paragraph; plus
    - (iv) A distance equivalent to 2 seconds at the  $V_1$  for take-off from a dry runway.
  - (2) The sum of the distances necessary to:
    - (i) Accelerate the aeroplane from a standing start with all engines operating to the highest speed reached during the rejected take-off, assuming the pilot takes the first action to reject the take-off at the  $V_1$  for take-off from a dry runway; and

Disclaimer – This document is not exhaustive and it will be updated gradually.





- (ii) With all engines still operating, come to a full stop on a dry runway from the speed reached as prescribed in subparagraph (a)(2)(i) of this paragraph; plus
  - (iii) A distance equivalent to 2 seconds at the  $V_1$  for take-off from a dry runway.
- (b) (See ACJ 25.109(a).) The accelerate-stop distance on a wet runway is the greater of the following distances:
- (1) The accelerate-stop distance on a dry runway determined in accordance with subparagraph (a) of this paragraph; or
  - (2) The accelerate-stop distance determined in accordance with subparagraph (a) of this paragraph, except that the runway is wet and the corresponding wet runway values of  $V_{EF}$  and  $V_1$  are used. In determining the wet runway accelerate-stop distance, the stopping force from the wheel brakes may never exceed:
    - (i) The wheel brakes stopping force determined in meeting the requirements of JAR 25.101(i) and subparagraph (a) of this paragraph; and
    - (ii) The force resulting from the wet runway braking coefficient of friction determined in accordance with subparagraphs (c) or (d) of this paragraph, as applicable, taking into account the distribution of the normal load between braked and unbraked wheels at the most adverse centre of gravity position approved for take-off.
- (c) The wet runway braking coefficient of friction for a smooth wet runway is defined as a curve of friction coefficient versus ground speed and must be computed as follows:
- (1) The maximum tyre-to-ground wet runway braking coefficient of friction is defined as:

Tyre Pressure	(psi)	Maximum Braking Coefficient (tyre-to-ground)
50		$\mu_{t/g \max} = -0.0350\left(\frac{V}{100}\right)^3 + 0.306\left(\frac{V}{100}\right)^2 - 0.851\left(\frac{V}{100}\right) + 0.883$
100		$\mu_{t/g \max} = -0.0437\left(\frac{V}{100}\right)^3 + 0.320\left(\frac{V}{100}\right)^2 - 0.805\left(\frac{V}{100}\right) + 0.804$
200		$\mu_{t/g \max} = -0.0331\left(\frac{V}{100}\right)^3 + 0.252\left(\frac{V}{100}\right)^2 - 0.658\left(\frac{V}{100}\right) + 0.692$
300		$\mu_{t/g \max} = -0.0401\left(\frac{V}{100}\right)^3 + 0.263\left(\frac{V}{100}\right)^2 - 0.611\left(\frac{V}{100}\right) + 0.614$

Where:

Tyre Pressure = maximum aeroplane operating tyre pressure (psi)

$\mu_{t/g \max}$  = maximum tyre-to-ground braking coefficient

V = aeroplane true ground speed (knots); and

Linear interpolation may be used for tyre pressures other than those listed.

- (2) (See ACJ 25.109(c)(2)) The maximum tyre-to-ground wet runway braking coefficient of friction must be adjusted to take into account the efficiency of the anti-skid system on a wet runway. Anti-skid system operation must be demonstrated by flight testing on a
- Disclaimer – This document is not exhaustive and it will be updated gradually.



smooth wet runway and its efficiency must be determined. Unless a specific anti-skid system efficiency is determined from a quantitative analysis of the flight testing on a smooth wet runway, the maximum tyre-to-ground wet runway braking coefficient of friction determined in subparagraph (c)(1) of this paragraph must be multiplied by the efficiency value associated with the type of anti-skid system installed on the aeroplane:

Type of anti-skid system	Efficiency value
On-Off	0.30
Quasi modulating	0.50
Fully modulating	0.80

(d) At the option of the applicant, a higher wet runway braking coefficient of friction may be used for runway surfaces that have been grooved or treated with a porous friction course material. For grooved and porous friction course runways, the wet runway braking coefficient of friction is defined as either:

(1) 70% of the dry runway braking coefficient of friction used to determine the dry runway accelerate stop distance; or

(2) (See ACJ 25.109(d)(2)). The wet runway braking coefficient of friction defined in subparagraph (c) of this paragraph, except that a specific anti-skid efficiency, if determined, is appropriate for a grooved or porous friction course wet runway and the maximum tyre to-ground wet runway braking coefficient of friction is defined as:

Tyre Pressure (psi)                      Maximum Braking Coefficient (tyre-to-ground)

50	$\mu_{t/g \max} = 0.147\left(\frac{V}{100}\right)^5 - 1.05\left(\frac{V}{100}\right)^4 + 2.673\left(\frac{V}{100}\right)^3 - 2.683\left(\frac{V}{100}\right)^2 + 0.403\left(\frac{V}{100}\right) + 0.859$
100	$\mu_{t/g \max} = 0.1106\left(\frac{V}{100}\right)^5 - 0.813\left(\frac{V}{100}\right)^4 + 2.13\left(\frac{V}{100}\right)^3 - 2.20\left(\frac{V}{100}\right)^2 + 0.317\left(\frac{V}{100}\right) + 0.807$
200	$\mu_{t/g \max} = 0.0498\left(\frac{V}{100}\right)^5 - 0.398\left(\frac{V}{100}\right)^4 + 1.14\left(\frac{V}{100}\right)^3 - 1.285\left(\frac{V}{100}\right)^2 + 0.140\left(\frac{V}{100}\right) + 0.701$
300	$\mu_{t/g \max} = 0.0314\left(\frac{V}{100}\right)^5 - 0.247\left(\frac{V}{100}\right)^4 + 0.703\left(\frac{V}{100}\right)^3 - 0.779\left(\frac{V}{100}\right)^2 - 0.00954\left(\frac{V}{100}\right) + 0.614$

Where:

Tyre Pressure = maximum aeroplane operating tyre pressure (psi)

$\mu_{t/g \max}$  = maximum tyre-to-ground braking coefficient

V = aeroplane true ground speed (knots); and

Linear interpolation may be used for tyre pressures other than those listed.

(e) Except as provided in sub-paragraph (f)(1) of this paragraph, means other than wheel brakes may be used to determine the accelerate-stop distance if that means:

(1) Is safe and reliable;

Disclaimer – This document is not exhaustive and it will be updated gradually.



- (2) Is used so that consistent results can be expected under normal operating conditions; and
  - (3) Is such that exceptional skill is not required to control the aeroplane.
- (f) The effects of available reverse thrust:
- (1) Shall not be included as an additional means of deceleration when determining the accelerate-stop distance on a dry runway; and
  - (2) May be included as an additional means of deceleration using recommended reverse thrust procedures when determining the accelerate-stop distance on a wet runway, provided the requirements of sub-paragraph (e) of this paragraph are met. (See ACJ 25.109(f))
- (g) The landing gear must remain extended throughout the accelerate-stop distance.
- (h) If the accelerate-stop distance includes a stop way with surface characteristics substantially different from those of the runway, the take-off data must include operational correction factors for the accelerate-stop distance. The correction factors must account for the particular surface characteristics of the stop way and the variations in these characteristics with seasonal weather conditions (such as temperature, rain, snow and ice) within the established operational limits.
- (i) A flight test demonstration of the maximum brake kinetic energy accelerate-stop distance must be conducted with not more than 10% of the allowable brake wear range remaining on each of the aeroplane wheel brakes.

## 2.5 Amendment to JAR 25.113: Take-Off Distance and Take-Off Run

Amend sub-paragraph (a), add a new sub-paragraph (b), amend existing sub-paragraph (b) and re-designate it as (c) and add a new sub-paragraph (d). JAR 25.113 then reads as follows:

### JAR 25.113 Take-off distance and take-off run

- (a) Take-off distance on a dry runway is the greater of:
- (1) The horizontal distance along the take-off path from the start of the take-off to the point at which the aeroplane is 35 ft. above the take-off surface, determined under JAR 25.111 for a dry runway; or
  - (2) 115% of the horizontal distance along the take-off path, with all engines operating, from the start of the take-off to the point at which the aeroplane is 35 ft above the take-off surface, as determined by a procedure consistent with JAR 25.111. (See ACJ 25.113 (a)(2)).
- (b) Take-off distance on a wet runway is the greater of:
- (1) The take-off distance on a dry runway determined in accordance with sub-paragraph (a) of this paragraph; or
  - (2) The horizontal distance along the take-off path from the start of the take-off to the point at which the aeroplane is 15 ft above the take-off surface, achieved in a

Disclaimer – This document is not exhaustive and it will be updated gradually.



manner consistent with the achievement of  $V_2$  before reaching 35 ft above the take-off surface, determined under JAR 25.111 for a wet runway.  
(See ACJ 113 (a)(2)).

- (c) If the take-off distance does not include a clearway, the take-off run is equal to the take-off distance. If the take-off distance includes a clearway:
- (1) The take-off run on a dry runway is the greater of:
    - (i) The horizontal distance along the take-off path from the start of the take-off to a point equidistant between the point at which  $V_{LOF}$  is reached and the point at which the aeroplane is 35 ft above the take-off surface, as determined under JAR 25.111 for a dry runway; or
    - (ii) 115% of the horizontal distance along the take-off path, with all engines operating, from the start of the take-off to a point equidistant between the point at which  $V_{LOF}$  is reached and the point at which the aeroplane is 35 ft. above the take-off surface, determined by a procedure consistent with JAR 25.111. (See ACJ 25.113(a)(2)).
  - (2) The take-off run on a wet runway is the greater of:
    - (i) The horizontal distance along the take-off path from the start of the take-off to the point at which the aeroplane is 15 ft above the take-off surface, achieved in a manner consistent with the achievement of  $V_2$  before reaching 35 ft above the take-off surface, determined under JAR 25.111 for a wet runway; or
    - (ii) 115% of the horizontal distance along the take-off path, with all engines operating, from the start of the take-off to a point equidistant between the point at which  $V_{LOF}$  is reached and the point at which the aeroplane is 35 ft above the take-off surface, determined by a procedure consistent with JAR 25.111. (See ACJ 25.113(a)(2)).

## 2.6 Amendment to JAR 25.115 Take-off flight path

Amend sub-paragraph (a) to read as follows:

JAR 25.115 Take-off flight path:

- (a) The take-off flight path shall be considered to begin 35 ft above the take-off surface at the end of the take-off distance determined in accordance with JAR 25.113(a) or (b) as appropriate for the runway surface condition.

## 2.7 Amendment to JAR 25.735: Brakes

See Special Condition S 1021

## 2.8 Amendment to JAR 25.1533(a)(3): Additional operating limitations

Amend JAR 25.1533(a)(3) to read as follows:

- (3) The minimum take-off distances must be established as the distances at which compliance is shown with the applicable provisions of this JAR-25 (including the provisions of JAR 25.109 and JAR 25.113, for weights, altitudes, temperatures, wind components, runway surface conditions (dry and wet) and runway gradients) for smooth, hard-surfaced runways.

Disclaimer – This document is not exhaustive and it will be updated gradually.



Additionally, at the option of the applicant, wet runway take-off distances may be established for runway surfaces that have been grooved or treated with a porous friction course and may be approved for use on runways where such surfaces have been designed, constructed and maintained in a manner acceptable to the Authority. (See ACJ 25.1533(a)(3)).

## 2.9 Amendment to JAR 25X1591: Supplementary performance information

2.9.1 Delete the words "wet and" on the sixth line of sub-paragraph (a).

2.9.2 Delete "wet/" from the 3<sup>rd</sup> and 6<sup>th</sup> lines of sub-paragraph (b).

2.9.3 Delete sub-paragraph (c)(1) and combine the introduction to sub-paragraph (c) with (c)(2) to read as follows:

- (c) Supplementary performance information for runways contaminated with standing water, slush, loose snow, compacted snow or ice must be furnished. Information on the effect of runway contaminants on the expected performance of the aeroplane during take-off and landing on hard-surfaced runways must be furnished. If it appears in the aeroplane Flight Manual, this information must be segregated, identified as guidance material and clearly distinguished from the additional operating limitations of JAR 25.1533 and the performance information of JAR 25.1587.

## Acronyms and Abbreviations

<b>JAR</b>	Joint Aviation Regulation
<b>ACJ</b>	Advisory Circular Joint
<b>NPA</b>	Notice of Proposed Amendment
<b>RTO</b>	Rejected Take-Off
<b>LOF</b>	Lift Off Speed

Disclaimer – This document is not exhaustive and it will be updated gradually.



**F-1014: REVISION OF GATE REQUIREMENTS FOR HIGH-LIFT DEVICE CONTROLS**

<b>SPECIAL CONDITION</b>	<b>F-1014: Revision of Gate requirements for High-Lift Device Controls</b>
APPLICABILITY:	A340-500/-600
REQUIREMENTS:	JAR 25.697(a)(b), 25.145(b)(c)
ISSUE:	2 dated 18/08/2000

**Special condition summary**

**BACKGROUND**

The principal requirements relating to flap gates are 25.697 (a) and (b), 25.145 (b) and (c). In addition, JAR 1 gives a definition of a gate.

The current JAR 25 requirements are not fully consistent with modern practice. Furthermore, if these requirements were to be applied literally, this would result in too many gates in the quadrant which would cause confusion in a high workload environment.

**SPECIAL CONDITION**

Move the last paragraph of JAR 25.145(c) to a new JAR 25.145(e) with ACJ 25.145(e) and amend it to read:

"If gated high-lift device control positions are provided, subparagraph (c) of this paragraph applies to retractions of the high-lift devices from any position from the maximum landing position to the first gated position, between gated positions, and from the last gated position to the fully retracted position. The requirements of sub-paragraph (c) of this paragraph also apply to retractions from each approved landing configuration to the control position(s) associated with the high-lift device configuration(s) used to establish the go-around procedure(s) from that landing position. In addition, the first gated control position from the maximum landing position must correspond with a configuration of the high-lift devices used to establish a go-around procedure from a landing configuration. Each gated control position must require a separate and distinct motion of the control to pass through the gated position and must have features to prevent inadvertent movement of the control through the gated position. It must only be possible to make this separate and distinct motion once the control has reached the gated position."

Delete the definition of a gate contained in JAR -1.

**Acronyms and Abbreviations**

<b>JAR</b>	Joint Aviation Regulation
------------	---------------------------

Disclaimer – This document is not exhaustive and it will be updated gradually.



## G-5: RESISTANCE TO FIRE TERMINOLOGY

<b>SPECIAL CONDITION</b>	<b>G-5: Resistance to fire terminology</b>
APPLICABILITY:	A330 / A340
REQUIREMENTS:	JAR 1, JAR 25.853, JAR 25.863, JAR 25.867, ACJ 25.1181
ISSUE:	2 dated 07/05/1991

### Special Condition summary

## BACKGROUND

Although Orange Paper (OP) 91/1 is not applicable to A330/A340 aircraft models it has been found by the JAA that the NPA 25D-181 is of sufficient importance as to be applied as special condition in accordance with draft JAR 21.16(a)/JCP document par.4.2.

## SPECIAL CONDITION

1. Amend JAR 25.853(e) to read:  
(e) Each disposal receptacle for towels paper or waste must be fully enclosed and constructed of materials adequate in resistance to fire such that any fire likely to occur in it under normal use will be contained. The ability of the disposal receptacle to contain those fires under all probable conditions of wear, misalignment and ventilation expected in service must be demonstrated by test. A placard containing the legible words "No Cigarette Disposal" must be located on or near each disposal receptacle door.
2. Amend JAR 25.863(b)(4) to read:  
(4) Means available for controlling or extinguishing a fire, such as stopping flow of fluids, shutting down equipment, fire containment, or use of extinguishing agents.
3. Amend JAR 25.863(b)(4) to read:  
(a) Surfaces to the rear of the nacelles, within one nacelle diameter of the nacelle centreline must be constructed of materials at least equivalent in resistance to fire as aluminium alloy in dimensions appropriate for the purpose for which they are used.

## Acronyms and Abbreviations

<b>JAR</b>	Joint Aviation Regulation
<b>OP</b>	Orange Paper
<b>NPA</b>	Notice of Proposal Amendment

Disclaimer – This document is not exhaustive and it will be updated gradually.





## G-7: FUNCTION AND RELIABILITY TESTING

<b>SPECIAL CONDITION</b>	<b>G-7: Function and reliability testing</b>
APPLICABILITY:	A330 / A340
REQUIREMENTS:	JAR 21.35
ISSUE:	2 dated 02/10/1992

### Special Condition summary

## BACKGROUND

There are no JAR 25 requirements requiring actual demonstration that the aircraft, its components, and its equipment are reliable and function properly.

In view of the reduction or suppression of the national requirements, harmonisation condition based on CC paper 36.3 issue 2 and associated interpretative material was issued.

## SPECIAL CONDITION

(a) The applicant must make all flight tests that the Authority finds necessary:

- (1) To determine compliance with applicable certification requirements
- (2) To determine whether there is a reasonable assurance that the aircraft, its components, and its equipment are reliable and function properly.

(b) The flight tests prescribed in sub paragraph (a)(2) of this SC must include:

- (1) For aircraft incorporating turbine engines of a type not previously used on a type certificated aircraft, at least 300 hours of operation with a full complement of engines that conform to a type certificate.
- (2) For all other aircraft, at least 150 hours of operation.

## Acronyms and Abbreviations

<b>JAR</b>	Joint Aviation Regulation
<b>SC</b>	Special Condition

Disclaimer – This document is not exhaustive and it will be updated gradually.





**H-01: ENHANCED AIRWORTHINESS PROGRAMME FOR AEROPLANE SYSTEMS - ICA ON EWIS**

<b>SPECIAL CONDITION</b>	<b>H-01: Enhanced Airworthiness Programme for Aeroplane Systems - ICA on EWIS</b>
APPLICABILITY:	A330/A340
REQUIREMENTS:	21A.16B(a)(3), 21A.3B(c)(1), CS 25.1529 & App. H
ADVISORY MATERIAL:	2 dated 06/05/2010

**Special Condition summary**

**BACKGROUND**

To enhance the safety of large aeroplanes wiring systems, EASA has developed in cooperation with FAA a regulatory package including new and revised certification and maintenance requirements to address shortcomings of current wiring systems design, installation and maintenance practices. These new certification requirements are contained in CS-25 amendment 5 dated 5 September 2008.

EASA has requested Airbus, as holder of type certificates of A330 aircraft models, to develop appropriate Instructions for Continued Airworthiness (ICA) on the Electrical Wiring Interconnection System (EWIS), derived from the Enhanced Zonal Analysis Procedure (EZAP) in accordance with CS-25 Appendix H paragraph H25.5. These ICA's must be furnished before 10 December 2009 or the date of issuance of the certificate whichever occur later.

**SPECIAL CONDITION**

The applicant must prepare Instructions for Continued Airworthiness (ICA) applicable to Electrical Wiring Interconnection System (EWIS) as defined below that include the following:

Maintenance and inspection requirements for the EWIS developed with the use of an enhanced zonal analysis procedure (EZAP) that includes:

- (a) Identification of each zone of the aeroplane.
- (b) Identification of each zone that contains EWIS.
- (c) Identification of each zone containing EWIS that also contains combustible materials.
- (d) Identification of each zone in which EWIS is in close proximity to both primary and back-up hydraulic, mechanical, or electrical flight controls and lines.
- (e) Identification of -
  - Tasks, and the intervals for performing those tasks, that will reduce the likelihood of ignition sources and accumulation of combustible material, and
  - Procedures, and the intervals for performing those procedures, that will effectively clean the EWIS components of combustible material if there is not an effective task to reduce the likelihood of combustible material accumulation.

Disclaimer – This document is not exhaustive and it will be updated gradually.



(f) Instructions for protections and caution information that will minimize contamination and accidental damage to EWIS, as applicable, during the performance of maintenance, alteration, or repairs.

The ICA must be in the form of a document appropriate for the information to be provided, and they must be easily recognizable as EWIS ICA.

For the purpose of this Appendix H25.5, the following EWIS definition applies:

(a) Electrical wiring interconnection system (EWIS) means any wire, wiring device, or combination of these, including termination devices, installed in any area of the aeroplane for the purpose of transmitting electrical energy, including data and signals between two or more intended termination points. Except as provided for in subparagraph (c) of this paragraph, this includes:

- (1) Wires and cables.
- (2) Bus bars.
- (3) The termination point on electrical devices, including those on relays, interrupters, switches, contactors, terminal blocks, and circuit breakers and other circuit protection devices.
- (4) Connectors, including feed-through connectors.
- (5) Connector accessories.
- (6) Electrical grounding and bonding devices and their associated connections.
- (7) Electrical splices.
- (8) Materials used to provide additional protection for wires, including wire insulation, wire sleeving, and conduits that have electrical termination for the purpose of bonding.
- (9) Shields or braids.
- (10) Clamps and other devices used to route and support the wire bundle.
- (11) Cable tie devices.
- (12) Labels or other means of identification.
- (13) Pressure seals.

(b) The definition in subparagraph (a) of this paragraph covers EWIS components inside shelves, panels, racks, junction boxes, distribution panels, and back-planes of equipment racks, including, but not limited to, circuit board back-planes, wire integration units and external wiring of equipment.

(c) Except for the equipment indicated in subparagraph (b) of this paragraph, EWIS components inside the following equipment, and the external connectors that are part of that equipment, are excluded from the definition in subparagraph (a) of this paragraph:

- (1) Electrical equipment or avionics that is qualified to environmental conditions, and testing procedures when those conditions and procedures are -
  - (i) Appropriate for the intended function and operating environment, and
  - (ii) Acceptable to the Agency.

Disclaimer – This document is not exhaustive and it will be updated gradually.



- 
- (2) Portable electrical devices that are not part of the type design of the aeroplane. This includes personal entertainment devices and laptop computers.
  - (3) Fibre optics.

### Acronyms and Abbreviations

<b>EWIS</b>	Electrical Wiring Interconnection System
<b>EZAP</b>	Enhanced Zonal Analysis Procedure
<b>ICA</b>	Instructions for Continued Airworthiness
<b>EASA</b>	European Aviation Safety Agency
<b>FAA</b>	Federal Aviation Administration
<b>CS</b>	Certification specification

Disclaimer – This document is not exhaustive and it will be updated gradually.



---

## O-1001: FERRYING ONE ENGINE UNSERVICEABLE

<b>SPECIAL CONDITION</b>	<b>O-1001: Ferrying one engine unserviceable</b>
APPLICABILITY:	A340-500/-600
REQUIREMENTS:	JAR 25X20
ISSUE:	2 dated 06/06/2001

### Special Condition summary

#### BACKGROUND

Airbus Industrie applies for operation of ferrying with one engine unserviceable. The authorisation to perform such a ferry flight is an operational responsibility and there will be requirements and guidelines in the European operational regulation on this subject.

However, there is a need to define standards and conditions for such a ferry flight. These are usually detailed in an appendix to the AFM approved by the certification authority.

For basic A340 aircraft models, Special Condition was issued, based on an initial version of NPA 25B-FRR.

Since then, the JAR Flight Study Group have produced draft NPA 25B-239 which details the basis on which the AFM appendix can be approved, with respect to handling qualities and performance requirements.

#### SPECIAL CONDITION

#### PARAGRAPHS AFFECTED

JAR 25X20 Applicability

#### PROPOSAL

Introduce Supplementary Information as follows;

JAR 25X20(d) (see Appendix FRR)

Where a manufacturer chooses to furnish supplementary information to permit ferrying a three or four engined aircraft with one engine unserviceable the additional requirements of Appendix FRR must be complied with.

Appendix FRR

Supplementary information for ferrying a 3 or 4 engined aircraft with one unserviceable engine (see JAR 25 X 20(d)).

#### 1. APPLICABILITY

Disclaimer – This document is not exhaustive and it will be updated gradually.



The requirements of this Appendix are applicable for the purpose of ferrying a large transport aeroplane with one engine unserviceable. Additional requirements may be prescribed when it is considered that the characteristics of the aeroplane necessitate such requirements.

The level of airworthiness given by this AMJ is lower than that normally assumed by JAR 25 and is suitable for non-revenue, non passenger transport operations to return the aircraft to a place where an engine may be repaired or changed.

The unserviceable engine appropriate to each case below shall be the engine which was critical for the equivalent case during the determination of the normal performance and handling, except that for ferrying minimum control speeds the unserviceable engine shall be that which in association with the failure of a serviceable engine will give the highest minimum control speed. The configuration of the unserviceable engine assumed in establishing the below data shall be scheduled, e.g., propeller feathered, propeller removed, engine locked, etc.

## 2. DEFINITIONS

### 2.1 Unserviceable Engine

The engine which is inoperative before flight and which remains inoperative throughout.

### 2.2 Serviceable Engine

An engine which is intended to operate throughout the flight.

## 3. FLIGHT REQUIREMENTS

### 3.1 Take Off

#### 3.1.1 Take-off Technique

The prescribed take-off data shall be based on a flight technique which permits adequate control at all points in the take-off in the event of cross winds, wet runway and failure of a serviceable engine where it occurs after the decision to become airborne is taken, giving adequate allowance for pilot reaction time.

Note: Where adequate control is not possible on a wet runway, it will be acceptable to introduce a limitation restricting take-off to dry runway conditions only.

#### 3.1.2 Minimum Control Speeds

The Ferrying  $V_{MCA}$  and  $V_{MCG}$  shall be the speeds arrived at by applying the requirements of JAR 25.149 with the aeroplane initially in the ferrying configuration.

#### 3.1.3 Take-Off Speeds

(a) The ferrying  $V_2$  shall be not less than:

- (i) That defined by JAR 25.107(c); and

Disclaimer – This document is not exhaustive and it will be updated gradually.



- (ii) 1.07 times the ferrying  $V_{MCA}$ .
- (b) The ferrying  $V_R$  shall be not less than:
  - (i) That defined by JAR 25.107(e);
  - (ii) 1.03 times the ferrying  $V_{MCA}$
  - (iii) The ferrying  $V_{MCG}$ ; and
  - (iv) A speed which enables the ferrying  $V_2$  to be achieved at a height of 35 ft. when taking off with all serviceable engines operating.
- (c) The ferrying  $V_{STOP}$  shall be the speed to which the aircraft can be accelerated with all serviceable engines operating, and brought to a full stop within the available accelerate stop distance determined in accordance with the general provisions of JAR 25.109(a)(1), (b), (c), (d), (e), (f), (g).

#### 3.1.4 Take-off Run and Take-Off Distance

The ferrying take-off run and distance shall be 1.15 times the gross distance to 35 ft, the aircraft being accelerated with all serviceable engines operating from the brakes-off point to the Ferrying Rotation Speed, and thereafter climbing to a height of 35 ft. at which point the speed shall not be less than the Ferrying  $V_2$ .

NOTE: The ferrying take-off distance does not include credit for clearway.

#### 3.1.5 Net Take-off Flight Path

The ferrying net take-off flight path which extends from a height of 35 ft to 1,500 ft shall be the gross flight path with one serviceable power unit inoperative reduced by gradient of 0.5%.

Note:

- (i) Where it is not possible to effect a geometry change (e.g., gear or flaps retraction) with one combination of any two engines inoperative, the take-off net flight path shall be determined for the most adverse configuration throughout, and shall be applicable where either of these two engines is the unserviceable engine at the beginning of the flight.
- (ii) Except where stated the conditions of speed and configuration shall be in accordance with JAR 25.111 and JAR 25.115.

### 3.2 Climb

#### 3.2.1 (a) Take-off: landing gear retracted.

At a height of 400 feet the steady gradient of climb shall not be less than 1.5% in the following conditions:

Airspeed	-	Ferrying $V_2$ .
Flaps	-	Ferrying take-off position.
Power	-	Critical serviceable engine inoperative, with the propeller feathered, the remaining engines being at MTOP.

Disclaimer – This document is not exhaustive and it will be updated gradually.



Landing gear - Retracted.

(b) Final take-off.

At a height of 1,500 ft. the en-route gross gradient of climb in the en-route configuration shall be not less than 1.2% in the following conditions:

Airspeed - Ferrying en-route climb speed but not less than  $1.18 V_{slg}$ .  
Flaps - Ferrying en-route position.  
Power - Critical serviceable engine inoperative, with the propeller feathered, the remaining engines being at MCP.  
Landing gear - Retracted.

Note: Para 3.2.1 (a) and (b). Where it is not possible to retract the landing gear or wing flaps with one combination of any two engines inoperative, compliance shall be shown with the landing gear extended and/or flaps in the ferrying take-off position.

Any consequent WAT limitations shall be applicable when either of these two engines is the unserviceable engine.

(c) Landing

The gross gradient of climb at the altitude of landing shall not be less than 2.0% in the following conditions:

Airspeed - Ferrying  $V_{REF}$  but not less than  $1.23 V_{slg}$  or that determined for normal operations in accordance with JAR 25.125(a)(2) and the associated ACJ.  
Flaps - Ferrying landing position.  
Power - All serviceable engines at the power or thrust that is available 8 seconds after initiation of movement of the power or thrust controls from the minimum flight idle to the take-off position.  
Landing gear - Extended.

### 3.2.2 Weight/Altitude/Temperature Limitations

(a) Compliance with paragraphs 3.2.1 (a) and (b) must be shown at each weight, altitude and ambient temperature within the operational limits established for take-off.

(b) Compliance with paragraphs 3.2.1 (b) and (c) must be shown at each weight, altitude and ambient temperature within the operational limits established for landing.

Note: The provisions of this paragraph mean that following the decision to land and selection of land flap the ability to carry out a go-around may not be assured in the event of failure of a serviceable engine.

### 3.2.3 En-route flight paths

(a) The airspeeds used in establishing all serviceable engines and the one serviceable engine inoperative net data must be not less than those used for final take-off (§3.2.1 (b)).

Disclaimer – This document is not exhaustive and it will be updated gradually.



- (b) The gross gradient of climb with all serviceable engines operating shall be determined and scheduled.
- (c) The net gradient of climb with the critical serviceable engine inoperative shall be determined and scheduled and shall be the gross gradient diminished by a gradient of 1.0%.

### 3.3 Landing

#### 3.3.1 Landing distance

The ferrying landing distance shall be that determined under JAR 25.125(a), except that the speed at 50 ft shall be not less than that determined under §3.2.1 (c) above. For an aircraft where a significant contribution to aerodynamic retardation is provided by the engines an additional 5% shall be added to the landing distance.

Note 1: In the determination of the ferrying landing distance it will be acceptable to calculate the increase due to any increase in reference speed.

Note 2: Where a reduction in available retardation from non-aerodynamic sources result when one combination of any two engines are inoperative, then appropriate allowances shall be made.

### 3.4 Crosswind

The maximum demonstrated ferrying crosswind components for both take-off and landing shall be determined.

## 4. FLIGHT MANUAL

Performance data for ferrying should be determined in accordance with the requirements paragraphs of this document. Procedures and information relating to configuration, piloting techniques, conditions for ferrying and permitted unserviceabilities should be included. AFM procedures should be relevant to the configuration of the inoperative engine and include reference to associated engine or system aspects.

The AFM should include a statement to the effect that the data does not in itself constitute an operational clearance and that such clearance should be sought from the appropriate authority.

## 5. REGULATORY STATUS

Supplementary AFM data should include an explanation of its regulatory status and include reference to applicable Operational Regulations where relevant.

Disclaimer – This document is not exhaustive and it will be updated gradually.





---

**Acronyms and Abbreviations**

<b>AFM</b>	Airplane Flight Manual
<b>MTOP</b>	Maintenance Task Operating Plan
<b>NPA</b>	Notice of Proposal Amendment
<b>JAR</b>	Joint Aviation Regulation
<b>WAT</b>	Weight Altitude Temperature
<b>AMJ</b>	Advisory Material Joint

Disclaimer – This document is not exhaustive and it will be updated gradually.



**P-1: FADEC**

<b>SPECIAL CONDITION</b>	<b>P-01: FADEC</b>
APPLICABILITY:	A330 / A340
REQUIREMENTS:	JAR 25.901, JAR 25.903
ISSUE:	2 dated 21/06/1991

**Special Condition summary**

**BACKGROUND**

The A330 / A340 engines incorporate a Full Authority Digital Engine Control (FADEC) ensuring electrical control and exchanging appropriate signals with the associated aircraft computers.

FADEC is considered an unusual feature. It must be shown that the safety level is not degraded compared with aircraft with hydro-mechanical engine control systems.

The adequacy of existing regulations, considering the principle of complementarity between compliance demonstrations at the level of aircraft certification (JAR 25) and at the level of engine certification (JAR E), was reviewed during the first phase of the joint A330 and A340 certification activities.

Based on these considerations, it appeared that the existing requirements, although adequate, for both engine and aircraft certification, might need special interpretations and acceptable specific means of compliance to be defined for engines equipped with electronic control.

In addition, a JAR 25/JAR E partitioning document providing the work-sharing between the engine and aircraft manufacturers has been established to cover A330 / A340 propulsion system certification (including FADEC).

**SPECIAL CONDITION**

The overall propulsion control system on the A330 / A340 aircraft models including the FADEC and associated electronic equipment, must be substantiated to have an availability of the functions essential for safe flight and landing, in the installed configuration, at least equivalent to those of a conventional propulsion control system of a similar type encompassing a hydro mechanical engine control system which has already been certified to the JAR regulations.

**Acronyms and Abbreviations**

<b>FADEC</b>	Full Authority Digital Engine Control
<b>JAR</b>	Joint Aviation Regulation

Disclaimer – This document is not exhaustive and it will be updated gradually.



## P-2: CENTRE OF GRAVITY CONTROL SYSTEM

<b>SPECIAL CONDITION</b>	<b>P-2: Centre of gravity control system</b>
APPLICABILITY:	A330 / A340
REQUIREMENTS:	JAR 25-27, 25-143, 25-161, 25-171 to 25-181, 25-631, 25-672, 25-951 to 25-1001, 25-1301, 25-1309, 25-1322, 25-1329 and 25-1351, 25-1431, SC S-06, SC S-10
ISSUE:	2 dated 09/10/1992

### Special Condition summary

## BACKGROUND

The A330 / A340 aircraft models are equipped with a centre of gravity (CG) control system using fuel transfer between the tailtank and the centre tank.

Applicable airworthiness requirements do not specifically take into consideration new system such as CG control systems and a special condition is necessary to cover this unusual feature.

## SPECIAL CONDITION

The following technical conditions are to be met:

### 1 – Bird Strike Damage

Current applicable requirement JAR 25.631 requires that aeroplane structure must be able to withstand a 4 lbs bird strike at the conditions developed in this paragraph.

Presence of fuel in the horizontal tailplane may potentially result in more serious sequences of events in case of bird strike causing damage to the tank structure. In particular, fuel or vapour may be released in areas where sources of ignition exist (APU, electrical bundles...).

Consequently:

- a) JAR 25-631 requirement must be met without creating a fuel leakage.
- b) The addition of fuel in the empennage must not impair the capability of the aircraft of safe flight and landing for any higher energy bird impact that would be survivable without fuel presence.

### 2 – Damage to Fuel Transfer Line in Pressurized Compartment

A means must be provided to isolate the tailplane tank from the main fuel system to minimize the risks of fuel spillage in lower part of fuselage, in case of accidental damage to fuel transfer lines. Typical events considered are:

- Crash landing
- Fatigue and vibrations
- Damage to supporting structure

Disclaimer – This document is not exhaustive and it will be updated gradually.



- High energy rotor burst
- Loose items of mass in cargo hold
- Installation and maintenance errors

Fuel transfer pipes located in the lower part of the fuselage must be at least fire resistant.

### 3 – Fuel Gravity Transfer

In addition to the provision of §25.1351 (d), it must be shown that fuel transfer from tailplane to centre tank is possible with normal electrical power inoperative in the most adverse position of tailplane encountered in all flight phases where transfer function is necessary for continued safe flight and landing.

### 4 – Unusable Fuel

Unusable fuel will be declared with the tailplane setting corresponding to aircraft trimmed for the considered flight phase.

### 5 – In addition to the criteria developed in §25.672 and 25.1309, the Following Apply

The aeroplane must be able to complete a safe flight and landing in case of absence of transfer. Unless it is shown that the aeroplane may meet this objective either naturally or by application of adequate procedures, the following arrangements could be considered satisfactory:

1. - Duplicate system with segregated transfer line
2. - Tailplane tank jettisoning system

In the analysis that will be provided to show compliance with JAR 25.1309, possible misloadings due to ground personnel will be taken into account.

### 6 – Target CG

Most rearward target CG must be established so that without any system failure in consideration of all CG control system settings and accuracies the certified CG aft limit will not be exceeded on a 2 sigma basis, taking account of:

- Initial CG computation error coming from either airline loading sheet system inaccuracy or weight and balance system performance (if installed).
- Passengers and crew movements.
- FCMC computation inaccuracy.

Alternately consideration of inaccuracies related to loading operational procedures may be accounted for by appropriate procedures and/or limitations in the Aeroplane Flight Manual.

### 7 – Aft CG Warning

The aeroplane must be fitted with an independent aft CG position warning which provides the flight crew with visual and aural warning whenever CG position exceeds aft certified limits.

It must be shown by analysis and simulation and/or flight tests that CG warning setting considering production tolerances and system accuracy is such that :

- a. Occurrence of nuisance warning in the normal flight envelop is minimized

Disclaimer – This document is not exhaustive and it will be updated gradually.



- b. No unsafe situation may result from flight at any CG position up to rear warning limit.
- c. There is a sufficient margin between the CG warning setting and the CG value beyond which an unsafe condition may be encountered.

Note 1: The limit rate of inadvertent warnings has to be assessed by test pilots during flight or simulator tests, the limit rate for late warnings will have to be assessed considering recovery actions.

### 8 – Software Classification

FCM computer software level classification shall be determined by an assessment, in accordance with JAR 25.1309 procedures, of the consequences on the aircraft of system failure. The software level will be declared in the Systems Safety Assessment.

Verification and validation of the level so derived will have to be demonstrated appropriately.

### 9 – Lightning and External Radiation Protection

SC S-6 and SC S-10 will have to be applied.

### 10 – Automatic Flight Control System

In addition to criteria developed in §25.1329 the following conditions must be shown:

- a. Absence of adverse oscillations of the AFS due to fuel movements in tailplane tank.
- b. No failure condition which would result in exceedance of certified aft CG limit when AFS is in use may prevent continued safe flight and landing unless this condition is shown to be extremely improbable.
- c. If use of AFS beyond certified aft CG limit is predicted disconnection should not require exceptional pilot skill or strength.

### 11 – Aeroplane Flight Manual

The AFM must indicate:

- a) System limitations
- b) Instructions for proper use of the system including procedures to be applied in case of system failures
- c) Performance information (if affected).

### **Acronyms and Abbreviations**

<b>AFM</b>	Aeroplane Flight Manual
<b>AFS</b>	Automatic Flight System
<b>APU</b>	Auxiliary Power Unit
<b>CG</b>	Centre of Gravity
<b>FCMC</b>	Fuel Control and Monitoring Computer
<b>SC</b>	Special Condition
<b>JAR</b>	Joint Aviation Regulation

Disclaimer – This document is not exhaustive and it will be updated gradually.



## P-27: FLAMMABILITY REDUCTION SYSTEM

<b>SPECIAL CONDITION</b>	<b>P-27: Flammability Reduction System</b> (consisting of Conditioned Serviced Air System (CSAS) and Inert Gas Generation System (IGGS))
APPLICABILITY:	A330 / A340
REQUIREMENTS:	JAR 25.1309, FAR 25.981 (c)
ISSUE:	3 dated 18/06/2010

### Special Condition summary

## BACKGROUND

On Airbus A330/340 a Flammability Reduction System (FRS) is introduced for the centre tank in the form of a Conditioned Service Air System (CSAS) and Inert Gas Generation System (IGGS) to reduce the flammability of the centre fuel tank by utilization of nitrogen enriched air (NEA).

The IGGS is intended to reduce the fleet average flammability exposure of the centre fuel tank to a level equal to or less than that of an unheated aluminium wing tank. The IGGS is intended to minimise the development of flammable vapours in compliance with FAR 25.981(c) amendment 25-125 (September 2008). JAR 25 does not contain any certification material applicable to IGGS. The IGGS represents technology and fuel tank inerting principles not previously used on this class of aircraft. This document defines special conditions to supplement existing JARs because existing requirements are not considered adequate or appropriate to set safety and performance standards for the design and installation of such systems.

This EASA special condition has been harmonized with the corresponding FAA special condition no. 25-285-SC for the Nitrogen Generating System installed on Boeing 747.

## SPECIAL CONDITION

### 1 – General

The following special conditions are part of the type design certification basis for Airbus A330/A340 with a centre tank equipped with a FRS.

Compliance with these special conditions does not relieve the applicant from compliance with the existing certification requirements.

These special conditions define additional requirements for the design and installation of a FRS that will inert fuel tanks with NEA in order to reduce the fleet average flammability exposure to 3% or less of the operational time for the aeroplane under evaluation. This 3% value is based upon the results of unheated wing tank Monte Carlo flammability analysis that gives results typically around this value. In order to address the high-risk phases of flight (i.e., warm/hot day pre-flight ground operations and climb where flammable conditions are more likely to occur), when the FRS is

Disclaimer – This document is not exhaustive and it will be updated gradually.



functional, it will be required to reduce the flammability exposure in each of these phases of operation to 3% or less of the operational time in those phases.

Irrespective of the addition of FRS, ignition source minimisation must still be applied to the tanks. Therefore the applicant is required to summarise modifications required for ignition source minimisation to be applied to the centre tank in compliance with INT/POL/25/12 (CS 25.1309).

The applicant may propose that MMEL relief is provided for aircraft operation with the FRS unavailable. Appropriate justification in accordance with normal policies and procedures including mitigating factors must be provided.

## 2 - Definitions

- (a) *Bulk Average Fuel Temperature*. The average fuel temperature within the fuel tank, or different sections of the tank if the tank is subdivided by baffles or compartments.
- (b) *Flammability Exposure Evaluation Time (FEET)*. For the purpose of these special conditions, the time from the start of preparing the aeroplane for flight, through the flight and landing, until all payload is unloaded and all passengers and crew have disembarked.  
In the Monte Carlo programme, the flight time is randomly selected from the Mission Range Distribution (Appendix 2, Table 3), the pre-flight times are provided as a function of the flight time, and the post-flight time is a constant 30 minutes.
- (c) *Flammable*. With respect to a fluid or gas, flammable means susceptible to igniting readily or to exploding. A non-flammable ullage is one where the gas mixture is too lean or too rich to burn and/or is inert per the definition below.
- (d) *Flash Point*. The flash point of a flammable fluid is the lowest temperature at which the application of a flame to a heated sample causes the vapour to ignite momentarily, or "flash". A test for jet fuel is defined in the ASTM specification, D56, "*Standard Test Method for Flash Point by Tag Close Cup Tester*".
- (e) *Hazardous Atmosphere*. An atmosphere that may expose any person(s) to the risk of death, incapacitation, impairment of ability to self-rescue (escape unaided from a space), injury, or acute illness.
- (f) *Inert*. For the purpose of these special conditions, the tank is considered inert when the bulk average oxygen concentration within each compartment of the tank is 12% or less at sea level up to 10,000 feet, then linearly increasing from 12% at 10,000 feet to 14.5% at 40,000 feet, and extrapolated linearly above that altitude (based on FAA test data).
- (g) *Inerting*. A process where a non-combustible gas is introduced into the ullage of a fuel tank to displace sufficient oxygen so that the ullage becomes inert.
- (h) *Monte Carlo Analysis*. An analytical tool that provides a means to assess the degree of fleet average and warm day flammability exposure time for a fuel tank. *Transport Effects*. Transport effects are the effects on fuel vapour concentration caused by low fuel conditions (mass loading), fuel condensation, and vaporisation.
- (i) *Ullage, or Ullage Space*. The volume within the tank not occupied by liquid fuel at the time interval under evaluation.

Disclaimer – This document is not exhaustive and it will be updated gradually.





### 3 - System Performance and Reliability

It must be demonstrated that the IGGS reduces tank flammability to levels defined in these special conditions. This should be shown by complying with performance and reliability requirements as follows:

- (a) The applicant must submit a combined fleet performance and reliability analysis (Monte Carlo analysis as described in Appendices 1 and 2) that must:
  - (1) Demonstrate that the overall fleet average flammability exposure of each fuel tank with a NGS installed is equal to or less than 3% of the FEET; and
  - (2) Demonstrate that neither the performance (when the FRS is operational) nor reliability (including all periods when the FRS is inoperative) contributions to the overall fleet average flammability exposure of a tank with a FRS installed are more than 1.8 percent (this will establish appropriate maintenance inspection procedures and intervals as required in paragraph 1.4 of these special conditions).
  
- (b) The applicant must submit a Monte Carlo analysis that demonstrates that the FRS, when functional, reduces the overall fleet average flammability exposure of each fuel tank with a FRS installed for warm day ground and climb phases to a level equal to or less than 3% of the FEET in each of these phases for the following conditions:
  - (1) The analysis must use the subset of 80°F (26.7°C) and warmer days from the Monte Carlo analyses done for overall performance, and
  - (2) The flammability exposure must be calculated by comparing the time during ground and climb phases for which the tank was flammable and not inert with the total time for the ground and climb phases.
  
- (c) The applicant must provide data from ground testing and flight testing that:
  - (1) validate the inputs to the Monte Carlo analysis needed to meet paragraphs 1.3(a), (b) and (c)(2) of these special conditions; and
  - (2) substantiate that the NEA distribution is effective at inerting all portions of the tank where the inerting system is needed to show compliance with these paragraphs.
  
- (d) The applicant must validate that the FRS meets the requirements of paragraphs (a), (b), and (c)(2) of this section with any combination of interfacing systems (eg electrical power system) approved for the aeroplane that may affect IGGS reliability and performance.
  
- (e) Sufficient accessibility for maintenance personnel, or the flightcrew, must be provided to FRS status indications that are necessary to meet the reliability requirements of paragraph 1.3(a) of these special conditions.

Disclaimer – This document is not exhaustive and it will be updated gradually.





(f) The access doors and panels to the fuel tanks (including any tanks that communicate with an inerted tank via a vent system), and to any other enclosed areas that could contain NEA under normal or failure conditions, must be permanently stenciled, marked, or placarded as appropriate to warn maintenance crews of the possible presence of a potentially hazardous atmosphere. The proposal for markings does not alter the existing requirements that must be addressed when entering aeroplane fuel tanks.

(g) Oxygen-enriched air produced by the FRS must not create a hazard during normal operating conditions.

(h) Any FRS failures, or failures that could affect the FRS, with potential catastrophic consequences shall not result from a single failure or a combination of failures not shown to be extremely improbable.

(1) It must be shown that the fuel tank pressures will remain within limits during normal operating conditions and failure conditions.

(2) Identify critical features of the fuel tank system to prevent an auxiliary fuel tank installation from increasing the flammability exposure of main tanks above that permitted under paragraphs 1.3(a)(1), (2) and (b) of these special conditions and to prevent degradation of the performance and reliability of the FRS.

#### 4 - Maintenance

The FRS shall be subject to analysis using conventional processes and methodology to ensure that the minimum scheduled maintenance tasks required for securing the continuing airworthiness of the system and installation are identified and published as part of the CS 25.1529 compliance. Maintenance tasks arising from either the Monte Carlo analysis or a CS 25.1309 safety assessment shall be dealt with in accordance with the principles laid down in FAA AC 25.19. The applicant shall prepare a validation programme for the associated continuing airworthiness maintenance tasks, fault finding procedures, and maintenance procedures.

#### 5 - In-Service Monitoring

Following introduction to service the applicant must introduce an event monitoring programme, accruing data from a reasonably representative sample of global operations, to ensure that the implications of component failures affecting the FRS are adequately assessed on an on-going basis. The applicant must:

(a) Provide a report to the primary certification authority (PCA) on a quarterly basis for the first five years of service introduction. After that period the requirement for continued reporting will be reviewed by the PCA.

(b) Provide a report to the validating authorities on a quarterly basis for a period of at least two years following introduction to service.

Disclaimer – This document is not exhaustive and it will be updated gradually.



(c) Develop service instructions or revise the applicable aeroplane manuals, in accordance with a schedule agreed by the PCA, to correct any failures of the IGGS that occur in service that could increase the fleet average or warm day flammability exposure of the tank to more than the exposure requirements of paragraphs 1.3(a) and 1.3(b) of these special conditions.

### Acronyms and Abbreviations

<b>JAR</b>	Joint Aviation Regulation
<b>CSAS</b>	Conditioned Serviced Air System
<b>IGGS</b>	Inert Gas Generation System
<b>FAR</b>	Federal Aviation Regulations
<b>FRS</b>	Flammability Reduction System
<b>NEA</b>	nitrogen enriched air
<b>EASA</b>	European Aviation Safety Agency
<b>FAA</b>	Federal Aviation Administration
<b>SC</b>	Special Condition
<b>MMEL</b>	Master Minimum Equipment List
<b>FEET</b>	Flammability Exposure Evaluation Time
<b>PCA</b>	Primary Certification Authority

Disclaimer – This document is not exhaustive and it will be updated gradually.



## P-32: FUEL TANK SAFETY

<b>SPECIAL CONDITION</b>	<b>P-32: Fuel Tank Safety</b>
APPLICABILITY:	A330-200/-300 / A340-200/-300
REQUIREMENTS:	CS 25.981
ISSUE:	3 dated 25/11/2013

### Special Condition summary

#### BACKGROUND

Following various in-service events, FAA and JAA have required Type Certificate holders to conduct design reviews in order to verify their products did not feature any unsafe condition possibly associated with fuel tank safety. FAA issued SFAR 88, which mandated FAR 25.981 as introduced by Amdt 102, and JAA required the members states to conduct design review per INT/POL/25/12.

It should be noted that while it is commonly stated that the products which were reviewed are 'SFAR 88 compliant' or 'INT/POL compliant', actually it was not practical for most designs to demonstrate full compliance to FAR 25.981 as introduced by Amdt 102. Instead, FAA and JAA agreed to use an additional filter - a harmonized unsafe condition criteria - to determine which corrective actions would be required to close the fuel tank safety design reviews. The unsafe condition criteria made a distinction between low and high flammability exposure tanks; while for high flammability exposure tanks full FAR 25.981 compliance was required, for low flammability exposure tanks the criteria relied on addressing 'no single failure', 'no known combination of failures', and 'no adverse in-service experience'.

Issuance of ADs on product fully compliant with their original certification demonstrates the original fuel tank safety requirements are not adequate. However, neither SFAR 88 nor INT/POL/25/12 have been formally introduced in the product certification basis., and still features the requirements established for the original certification of the product (in the case of the Airbus Long Range this is JAR 25 change 13). This resulted for subsequent design changes potentially affecting fuel tank safety in having a certification basis less stringent than the design review previously conducted to address SFAR 88.

Furthermore, the initial certification basis (typically, FAR 25.981 pre Amdt 102, or JAR / CS 25.981 pre Amdt 1) have been shown to be inappropriate as fully compliant designs had to be modified with corrective actions (including maintenance actions) to address potential unsafe conditions.

Relying exclusively on the unsafe condition criteria is not satisfactory. This criteria allowed to determine the existence of unsafe conditions, prompting the issuance of Airworthiness Directives, but were not drafted to address the safety objectives normally targeted for Type Certification.

Disclaimer – This document is not exhaustive and it will be updated gradually.



---

## SPECIAL CONDITION

CS 25.981 (a) at amendment 1 and the related AMC should be included in the certification basis of A330-200/300 and A340-200/300 aircraft, instead of the current JAR 25.981 at change 13, irrespectively of any Change Product Rule consideration. The applicant shall demonstrate that any design change potentially affecting fuel tank safety is compliant with CS 25.981 as modified at Amendment 1, and its associated guidance material as found in AMC 25.981 (a).

Note: CS 25.981 post Amendment 1 and FAR 25.981 post Amendment 102 are Significant Standard differences (SSD). While both requirements have their own backgrounds and merits, it certainly appears that some specific text of FAR 25.981 is difficult to address, for instance the considerations related to latent failure not shown to be extremely remote. EASA clearly does not intent to pre-empt the application of FAR 25.981 at Amendment 102 with this Special Condition.

## Acronyms and Abbreviations

<b>AD</b>	Airworthiness Directives
<b>SSD</b>	Significant Standard Differences
<b>CSAS</b>	Conditioned Service Air System
<b>AMC</b>	Acceptable Means of Compliance
<b>FAA</b>	Federal Aviation Administration
<b>JAA</b>	Joint Aviation Authorities
<b>FAR</b>	Federal Aviation Regulations
<b>INT/POL</b>	Interim Policy
<b>SFAR</b>	Special Federal Aviation Regulations

Disclaimer – This document is not exhaustive and it will be updated gradually.



## P-1008: FUEL TANK ACCESS COVERS

Equivalent Safety Finding	P-1008: Fuel tank access covers
APPLICABILITY:	A340-500/-600
REQUIREMENTS:	JAR 25. 963(g)
ISSUE:	2 dated 20/07/2001

### Equivalent Safety Finding summary

#### BACKGROUND

A340-500/-600 applicable Type Certification Basis is JAR 25 at change 14 plus JAR Amendment 25/96/1.

Airbus and JAA agreed on an equivalent safety finding to JAR 25.963(g) at change 14 plus JAR Amendment 25/96/1 as interpreted with ACJ 25.963(g), which proposes to apply the complete harmonised Fuel Tank Access Covers impact and fire resistance requirements agreed between JAA and FAA as established within the ARAC General Structure Working Group.

#### EQUIVALENT SAFETY FINDING

**In lieu of paragraph (g) of §25.963 "Fuel tanks: general" the following apply:**

Fuel tank access covers must comply with the following criteria in order to avoid loss of hazardous quantities of fuel:

- (1) All covers located in an area where experience or analysis indicates a strike is likely must be shown by analysis or tests to minimise penetration and deformation by tire fragments, low energy engine debris, or other likely debris.
- (2) All covers must have the capacity to withstand the heat associated with fire at least as well as an access cover made from aluminium alloy in dimensions appropriate for the purpose for which they are to be used, except that the access covers need not be more resistant to fire than an access cover made from the base fuel tank structural material.

#### Acronyms and Abbreviations

<b>ESF</b>	Equivalent Safety Finding
<b>JAR</b>	Joint Aviation Regulation
<b>ACJ</b>	Advisory Circular Joint
<b>JAA</b>	Joint Aviation Authorities
<b>ARAC</b>	Aviation Rulemaking Advisory Committee

Disclaimer – This document is not exhaustive and it will be updated gradually.



## **P-1009: ROLLS-ROYCE TRENT 500 TURBINE OVERHEAT DETECTION**

<b>Equivalent Safety Finding</b>	<b>P-1009: Rolls-Royce Trent 500 turbine overheat detection</b>
APPLICABILITY:	A340-500/600
REQUIREMENTS:	JAR 25.1203(d)
ISSUE:	2 dated 26/03/2001

### **Equivalent Safety Finding summary**

#### **BACKGROUND**

JAR 25.1203(d) states "there must be means to allow the crew to check, in flight, the functioning of each fire or overheat detector circuit".

The turbine overheat detection portion of the Airbus A340-500/-600 with Trent 500 design, as presently configured, does not allow the crew to check its functioning during flight. Although the fire zone compartment detector portion of the fire/overheat system can be fully tested in flight, and complies with JAR 25.1203(d), the inability to test the turbine overheat detection circuit in flight does not satisfy the testing provisions of this rule.

#### **EQUIVALENT SAFETY FINDING**

The turbine overheat detection system installed on the Rolls Royce Trent 500 engines fitted on A340-500/-600 aircraft ensures that the turbine does not overheat in case of failure of the internal cooling air system. This system is comprised of 4 thermocouples:

- 2 at the front of the Intermediate Pressure (IP) disc to protect the High Pressure (HP) and IP turbines from failure of the HP3 cooling air system
- 2 at the front of the LP disc to protect the Low Pressure (LP) turbine from failure of the IP8 cooling air system

Each thermocouple is associated to one EEC (Electronic Engine Control) channel. The EEC is in turn linked to the Flight Warning Computer (FWC) to generate a warning to the cockpit (with associated procedure), if an overheat is detected by the thermocouples.

The condition of the turbine overheat detection system is continuously monitored in-flight by the EEC and any system fault is signalled to the crew in -flight.

#### **Acronyms and Abbreviations**

<b>EEC</b>	Electronic Engine Control
<b>ESF</b>	Equivalent Safety Finding
<b>FWC</b>	Flight Warning Computer
<b>HP</b>	High Pressure
<b>IP</b>	Intermediate Pressure
<b>LP</b>	Low Pressure
<b>JAR</b>	Joint Aviation Regulation

Disclaimer – This document is not exhaustive and it will be updated gradually.



## P-1011: THRUST REVERSER TESTING

Equivalent Safety Finding	P-1011: Thrust Reverser testing
APPLICABILITY:	A340-500/-600
REQUIREMENTS:	JAR 25.934, JAR-E 890
ISSUE:	2 dated 24/10/2000

### Equivalent Safety Finding summary

#### BACKGROUND

This Equivalent Safety Finding was initially raised as Rolls Royce, the engine manufacturer, intended to use slave C-ducts instead of a real A340-500/-600 thrust reverser for the Trent 500 engine endurance certification test. The intent for this test was indeed to have as much flexibility as possible to change the nozzle size and thus reach the four engines redlines (LP, IP, HP shaft rotational speeds plus EGT). This initial position was later amended as the characteristics of the real thrust reverser were considered adequate for the test by Rolls Royce.

The initial compliance with JAR 25.934 and JAR-E890(b)(1) was therefore based on the installation of an A340-500/-600 thrust reverser on the engine certification endurance test as required by the regulation. This test was stopped due to an engine failure independent of the thrust reverser after 101,5 hours of engine functioning (out of the required 150 Hrs).

Following the failure, a new engine endurance certification test will be performed by Rolls Royce. For this new test, slave C-ducts will be fitted on the engine. An Equivalent Safety Finding is therefore proposed in order to demonstrate compliance to JAR 25.934.

ESF to JAR 25.934 could be accepted provided the applicant with the support of the engine manufacturer and the nacelist can show that the A340/500-600 thrust reverser as installed on the Trent 500 will meet the intent of JAR 25.934.

- 1- The stowed trust reverser does not adversely affect the correct functioning of the engine.
- 2- The stowed trust reverser is not adversely affected by engine functioning

This would be demonstrated for all engine settings and operating conditions, and throughout the full flight envelope.

#### EQUIVALENT SAFETY FINDING

##### 1) Engine endurance testing

The JAA agrees than an equivalent level of safety with JAR 25.934 which indirectly requires that the thrust reverser shall be fitted to the engine for the whole of the endurance test of JAR-E 740 (JAR E.890 (b)(1)(i)) can be shown.

Note: this is also accepted Rolls Royce Trent 500 Engine Type Certificate and associated Equivalent Safety Finding to JAR E - 740 - 150 Hour Endurance Test).

##### 2) Thrust Reverser Calibration testing

Disclaimer – This document is not exhaustive and it will be updated gradually.



---

JAR E-890(a) - Calibration Tests requires that "In complying with the requirements of JAR-E 170 and JAR – E 730 performance curves shall be included with the reverse thrust selected over the range of conditions for which approval is sought".

For aircraft JAR 25 certification, no credit is normally taken from thrust reverser calibration tests as the demonstration of reverse thrust efficiency is done by flight testing.

Therefore an equivalent level of safety to JAR 25.934 is shown.

### Acronyms and Abbreviations

<b>EGT</b>	Exhaust Gas Temperature
<b>ESF</b>	Equivalent Safety Finding
<b>HP</b>	High Pressure
<b>IP</b>	Intermediate Pressure
<b>LP</b>	Low Pressure
<b>JAR</b>	Joint Aviation Regulation
<b>JAA</b>	Joint Aviation Authorities

Disclaimer – This document is not exhaustive and it will be updated gradually.





## P-1016: REAR CENTER TANK & TYRE FAILURE

SPECIAL CONDITION	P-1016: Rear Center Tank & Tyre Failure
APPLICABILITY:	A340-500
REQUIREMENTS:	JAR 21.16(a)(1)(3), JAR 25. 729(f), JAR 25.1309, JAR 25.963(g)
ISSUE:	3 dated 14/10/2002

### Special Condition summary

#### BACKGROUND

The A340-500 features a Rear Centre Tank (RCT) located in the fuselage, located immediately behind the Centre Landing Gear (CLG) which is braked. This RCT can therefore be considered as a novel and unusual design feature.

While JAR 25.729(f) addresses the risk of tyre failure for equipment located within the wheel well, JAR-25 has no specific requirement addressing the risk of tyre burst for the general structure of the fuel tanks, which could be critical for some configurations such as for the A340-500 RCT.

*Note:* for the purpose of the A340-500/600 certification, the associated ACJ to JAR 25.963(g) has been replaced to take into account the result of harmonisation with FAA AC 25.963-1, please refer to CRI P-1008.

#### SPECIAL CONDITION

Part of the RCT structure is located in an area where experience indicates debris strikes due to tyre failure may occur. Therefore, it must be shown by analysis, tests, or both, that no hazardous fuel release from the RCT will occur following a tyre or wheel rim failure.

The following conditions should be addressed:

- The loading on the fuel tank due to impact in the risk area by tyre debris or other likely debris (secondary debris) resulting from a tyre failure event
- The loading of the structure adjacent to the impacted area due to:
  - a) The pressure resulting from fluid motion created by skin deformation in the impacted area and
  - b) The shock wave effect, if significant, induced in the fluid.

In the absence of a more rational method, the following may be used for the evaluation:

- For the tyre and other likely debris model:

#### Tyre Debris

Disclaimer – This document is not exhaustive and it will be updated gradually.



Tyre debris definitions and projection angles as defined in paragraph §1.1 of TGM 25/08 initial revision issued 1st of June 2000 (see appendix 1) but with an increased arc of vulnerability of 180° instead of 135°.

Other likely Debris

In the absence of relevant data, a 3/8 inch steel cube debris piece, at the relevant incidence angle, should be used. A projection angle within 30 degrees inboard and outboard of the tyre plane of rotation, measured from centre of tyre rotation with the gear in the down and locked position and the oleo strut in the nominal position, should be considered.

For the debris speed:

The velocity to be considered for all debris should be equal to the highest speed that the aircraft is likely to use on ground under normal operation.

If relevant, the additional speed transmitted to the debris by the tyre failure event itself should be accounted for.

- For the wheel rim model:

The Wheel rim release definitions for debris size, projection geometry and debris velocity as defined in §2.3 of the technical note SDF/B83/P/09/20065 Issue 1.

## Acronyms and Abbreviations

<b>JAR</b>	Joint Aviation Regulation
<b>TGM</b>	Temporary Guidance Material
<b>RCT</b>	Rear Centre Tank
<b>CLG</b>	Centre Landing Gear
<b>ACJ</b>	Advisory Circular Joint
<b>FAA</b>	Federal Aviation Administration

Disclaimer – This document is not exhaustive and it will be updated gradually.



## P-1018: ENGINE SUSTAINED IMBALANCE

<b>SPECIAL CONDITION</b>	<b>P-1018: Engine sustained imbalance</b>
APPLICABILITY:	A340-500/-600
REQUIREMENTS:	JAR 25.901, 25.903, 25.629, JAR 25.571
ISSUE:	3 dated 20/11:2001

### Special Condition summary

#### BACKGROUND

Service experience has shown that engine blade and bearing mechanical or structural failures may lead to high imbalance and vibratory loads in the airframe and engine. These vibratory loads may cause damage to primary structure and critical systems. Furthermore, vibrations on the flight deck may create a problem for the flight crew in flying the aeroplane. This CRI addresses the effects of sustained vibrations resulting from the failed engine, both before spool down and during the subsequent windmilling event. The dynamic transient loads occurring as a result of engine seizure and deceleration are not covered by this CRI.

#### SPECIAL CONDITION

It must be shown by a combination of tests and analyses, that Airbus A340-500/-600 aircraft are capable of continued safe flight and landing under the following conditions:

a) Windmilling condition:

This condition occurs after complete loss of an engine fan blade, or after a shaft support failure, including ensuing damage to other parts of the engine. The evaluation must show, that during continued operation at windmilling engine rotational speeds, the engine induced vibrations will not cause damage to either the primary structure of the airplane, or to critical equipment that would jeopardize continued safe flight and landing.

The evaluation must consider the effects from the possible damage to primary structure, including, but not limited to, engine mounts, wing, and flight control surfaces, as well as inlets, nacelles, and critical equipment (including connectors) mounted on the engine or the airframe. The degree of flight deck vibration must not prevent the flight crew from operating the airplane in a safe manner during all phases of flight.

The evaluation must cover the expected diversion time for the airplane.

b) High power condition:

This condition occurs immediately after partial engine blade failure which may not be sufficient to cause the engine to spool down on its own. It must be shown that:

- The attitude, airspeed, and altimeter indications will withstand the vibratory environment and operate accurately in that environment.

Disclaimer – This document is not exhaustive and it will be updated gradually.



---

- Adequate cues are available to the flight crew to determine which engine is damaged.

### Acronyms and Abbreviations

<b>JAR</b>	Joint Aviation Regulation
------------	---------------------------

Disclaimer – This document is not exhaustive and it will be updated gradually.



## P-1020: APU INSTRUMENTS

SPECIAL CONDITION	P-1020: APU Instruments
APPLICABILITY:	A340-500/-600
REQUIREMENTS:	JAR 25B1305
ISSUE:	2 dated 30/06/2000

### Special Condition summary

## BACKGROUND

NPA 25J246 "APU instruments" is modifying JAR 25 paragraph 25.1305 APU instruments. NPA 25J246 is considered mature, and should be included in the forthcoming change 15 of JAR 25. Therefore, JAA accept that NPA 25J246 be included in the A340-500/600 certification basis.

The following Special Condition SC P-1020 is applicable to A340-500/-600 aircraft models.

## SPECIAL CONDITION

JAR 25B1305 is modified to read:

JAR25B1305 APU instruments

- (a) The following instruments are required unless it can be shown that these are unnecessary to ensure safe operation of the unit :
- (1) A gas temperature indicator.
  - (2) A tachometer (to indicate the speed of the rotors) or overspeed warning.
  - (3) An oil pressure warning means.
- (a) The following instruments are required:
- (1) An indicator to indicate the functioning of the ice protection system, if such a system is installed.
  - (2) An indicator to indicate the proper functioning of any heater used to prevent ice clogging of fuel system components.

## Acronyms and Abbreviations

<b>NPA</b>	Notice of Proposed Amendment
<b>JAR</b>	Joint Aviation Regulation
<b>APU</b>	Auxiliary Power Unit
<b>JAA</b>	Joint Aviation Authorities
<b>SC</b>	Special Condition

Disclaimer – This document is not exhaustive and it will be updated gradually.



## P-1021: WINDMILLING WITHOUT OIL

<b>SPECIAL CONDITION</b>	<b>P-1021: Windmilling without oil</b>
APPLICABILITY:	A340-500/-600
REQUIREMENTS:	JAR 25.903 (c)(1)
ISSUE:	3 dated 28/08/2000

### Special Condition summary

#### BACKGROUND

NPA 25E268 deletes JAR 25.903 (c)(1).

NPA 25E268 is considered mature and it should be included in the forthcoming change 15 of JAR25.

Therefore, the JAA team accepts that NPA 25E268 be included in the A340-500/-600 certification basis.

Additionally, the JAA team confirms that the "windmill without oil" requirement is removed from JAR 25 because the requirement is now included both in FAR 33 and in JAR E, in a harmonised way through JAR-E NPA E-21, this NPA being part of Trent 500 Certification Basis through JAR E OP 97/1.

The following Special Condition SC P-1021 is applicable to A340-500/-600 aircraft models.

#### SPECIAL CONDITION

JAR 25.903(c)(1) is deleted, JAR 25.903(c)( 2) and (c)(3) are merged into a single JAR 25.903(c) which reads :

JAR25.903 Engines

*(c) Control of engine rotation.* There must be a means for stopping the rotation of any engine individually in flight, except that, for turbine engine installations, the means for stopping the rotation of any engine need be provided only where continued rotation could jeopardise the safety of the aeroplane. Each component of the stopping system on the engine side of the firewall that might be exposed to fire must be at least fire resistant. If hydraulic propeller feathering systems are used for this purpose, the feathering lines must be at least fire resistant under the operating conditions that may be expected to exist during feathering.

#### Acronyms and Abbreviations

<b>NPA</b>	Notice of Proposed Amendment
<b>JAR</b>	Joint Aviation Regulation
<b>JAA</b>	Joint Aviation Authorities

Disclaimer – This document is not exhaustive and it will be updated gradually.



## P-1022: FALLING AND BLOWING SNOW

<b>SPECIAL CONDITION</b>	<b>P-1022: Falling and blowing snow</b>
APPLICABILITY:	A340-500/-600
REQUIREMENTS:	JAR 25.1093 (b) JAR 25B1093 (b)
ISSUE:	2 dated 02/06/2000

### Special Condition summary

#### BACKGROUND

NPA 25E288 is still under discussions within Powerplant Harmonization Working Group , however those discussions are focusing around the proposed ACJ, the proposed requirement being agreed among all parties involved and harmonised with FAR 25.

Therefore, JAA accept that NPA 25E288 be included in the A340-500/-600 certification basis.

However, the JAA determined that the falling and blowing snow condition could also be applicable to essential APUs, consistently with the FAA policy. An APU falling and blowing snow requirement was not proposed for introduction in JAR 25 through NPA 25E288, because a major revision for harmonisation purposes of APU installation requirements (JAR-25 subpart J) was proposed under NPA 25J300, which includes a falling and blowing snow requirement.

Since the Advisory Material contained in NPA 25E288 does not address APUs, the JAA team proposes instead to use the draft ACJ No 2 to JAR 25.1093(b) technically agreed within the Powerplant Harmonisation Working Group.

The following Special Condition SC P 1022 is proposed to be applicable to A340-500/-600 Type Certification.

#### SPECIAL CONDITION

Add a paragraph (ii) to JAR 25.1093(b)(1) and JAR 25B1093(b)(1) to read as follows :

#### **"JAR 25.1093 Air intake system de-icing and anti-icing provisions**

##### (b) Turbine engines

- (1) Each turbine engine must operate throughout the flight power range of the engine (including idling), without the accumulation of ice on the engine, inlet system components, or airframe components that would adversely affect operation or cause a serious loss of power or thrust (see ACJ 25.1093(b)):
  - (i) Under the icing conditions specified in Appendix C.
  - (ii) In falling and blowing snow within the limitations established for the aeroplane for such operation."

Disclaimer – This document is not exhaustive and it will be updated gradually.



**"JAR 25B1093 Air intake system de-icing and anti-icing protection**

(b)(2) For APU's

Each air intake system of an essential APU, must be such as to enable the APU to operate throughout its flight power range without adverse effect on its operation or serious loss of power

(see ACJ 25J1093(b)(2)):

- (i) Under the icing conditions specified in Appendix C; and
- (ii) In falling and blowing snow within the limitations established for the aeroplane for such operations."

**Acronyms and Abbreviations**

<b>ACJ</b>	Advisory Circular Joint
<b>APU</b>	Auxiliary Power Unit
<b>SC</b>	Special Condition
<b>JAR</b>	Joint Aviation Regulation
<b>NPA</b>	Notice of Proposed Amendment
<b>JAA</b>	Joint Aviation Authorities
<b>FAA</b>	Federal Aviation Administration

Disclaimer – This document is not exhaustive and it will be updated gradually.





## P-1024: ECAM EGT INDICATION

Exemption (temporary)	P-1024: ECAM EGT indication
APPLICABILITY:	A340-600
REQUIREMENTS:	JAR 25.1549 (a) and (b)
ISSUE:	2 dated 30/04/2002

### Exemption (temporary) summary

#### BACKGROUND

JAR 25.1549(b), requires that "for each powerplant instrument either a placard or colour markings or an acceptable combination must be provided to convey information on the maximum and (where applicable) minimum operating limits. Colour coding must comply with the following: (a) Each maximum and, if applicable, minimum safe operating limit must be marked with a red radial or a red line; (b) Each normal operating range must be marked with a green arc or green line, not extending beyond the maximum and minimum safe limits".

This requirement is applicable to all types of powerplant instruments, from the classic "docks" with a needle to the most recent electronic screen displays. It is intended to provide a universal and unambiguous baseline allowing timely recognition by flight crews of parameter(s) exceeding allowed range. This requirement does however not take into consideration other recognition means, such as centralised warning/caution systems or EICAS/ECAM presenting automatically the procedures to the crews.

On the A340-642 with FADEC software L.3.2.3, which is the Type Certification Standard, it appears the take-off limit value for the Exhaust Gas Temperature (EGT, or TGT, in Rolls-Royce parlance) tabulated in the Electronic Engine Control is incorrect, at 920°C, whereas it should be 900°C. As a result, the EGT dial indication on the ECAM has a red arc starting at 920°C, and is therefore not compliant with JAR 25.1549(a) and (b).

#### EXEMPTION (TEMPORARY)

During the phase where the EGT overlimit warning is inhibited, the impact of the EGT red line shift from 900°C to 920°C is that a potential engine operation at EGT temperatures above 900°C, but below 920°C, for more than 20s will not be indicated to the crew. As the duration of the warning inhibition phase does not exceed 50s, the exposure time of this unannounced overlimit would not exceed 30s. JAR-E engine bench testing has shown that the engine is capable of sustaining safe operation at EGT temperatures up to 920°C for a longer duration than this 30s exposure time. It therefore confirms that there will be no detrimental effect on engine/aircraft safe operation during the final take-off phase due to the non-compliance with JAR 25.1549(a) and (b).

Disclaimer – This document is not exhaustive and it will be updated gradually.



---

**Acronyms and Abbreviations**

<b>EGT</b>	Exhaust Gas Temperature
<b>FADEC</b>	Full Authority Digital Engine Control
<b>TGT</b>	Turbine Gas Temperature
<b>JAR</b>	Joint Aviation Regulation
<b>EICAS</b>	Engine-Indicating and Crew-Alerting System
<b>ECAM</b>	Electronic Centralized Aircraft Monitoring

Disclaimer – This document is not exhaustive and it will be updated gradually.



### S-3: LANDING GEAR WARNING

<b>SPECIAL CONDITION</b>	<b>S-3: Landing Gear Warning</b>
APPLICABILITY:	A330 / A340
REQUIREMENTS:	JAR 25.729, NPA 25D-162
ISSUE:	4 dated 02/10/1992

#### Special Condition summary

### BACKGROUND

The current requirements are considered inadequate for modern aeroplanes. For this reason, NPA 25D-162 was issued. The FAA has also issued NPRM 89-20 on the same subject. The latest version of the NPA dated November 1991 covers both JAA and FAA objectives.

### SPECIAL CONDITION

Delete the existing sub-paragraph 25.729(e)(2) to (4) inclusive and substitute the following:

- 25.729(e)(2): The flight crew must be given an aural warning that functions continuously, or is periodically repeated, if a landing is attempted when the landing gear is not locked down.
- 25.729(e)(3): The warning must be given in sufficient time to allow the landing gear to be locked down or a go-around to be made.
- 25.729(e)(4): There must not be a manual shut-off means readily available to the flight crew for the warning required by paragraph (e)(2) of this section such that it could be operated instinctively, inadvertently or by habitual reflexive action.
- 25.729(e)(5): The system used to generate the aural warning must be designed to minimise false or inappropriate alerts.
- 25.729(e)(6): Failures of systems used to inhibit the landing gear aural warning, that would prevent the warning system from operating, must be improbable (See ACJ 25-729(e)).

### Acronyms and Abbreviations

<b>JAR</b>	Joint Aviation Regulation
<b>NPA</b>	Notice of Proposal Amendment
<b>FAA</b>	Federal Aviation Administration
<b>NPRM</b>	New Proposal Rule Making

Disclaimer – This document is not exhaustive and it will be updated gradually.



---

<b>JAA</b>	Joint Aviation Authorities
<b>ACJ</b>	Advisory Circular Joint

Disclaimer – This document is not exhaustive and it will be updated gradually.



## S-6: LIGHTNING PROTECTION INDIRECT EFFECTS

<b>SPECIAL CONDITION</b>	<b>S-6: Lightning protection indirect effects</b>
APPLICABILITY:	A330 / A340
REQUIREMENTS:	JAR 25.581, 25.X899, 25.954, 25.1309
ADVISORY MATERIAL:	3 dated 15/03/1991

### Special Condition summary

#### BACKGROUND

The A330/A340 are equipped with computers performing essential or critical functions, which must be protected against the effects of a lightning strike.

The JAA require that recent knowledge on severe lightning strike threat levels and probability, be taken into consideration in establishing the acceptability of the indirect effects lightning protection provisions employed.

#### SPECIAL CONDITION - CONCLUSION

Each system whose failure to function properly would prevent the continued safe flight and landing of the aircraft must be designed and installed to ensure that the operation of the aircraft is not affected during and after exposure to lightning.

Each system whose failure to function properly would reduce the capability of the aircraft or the ability of the flight crew to cope with adverse operating conditions, must be designed and installed to ensure that it can perform its intended function after exposure to lightning.

The lightning strike model to be used for system justification shall be as follows: it is based on SAE-AE4R report AE4L-87.3 rev. B dated January 1989.

#### Severe strike (first return stroke)

Peak amplitude	200 KA
Peak Rate of Rise	140 KA/micro-second
Action Integral bi-exponential wave shape	2 x 10 <sup>6</sup> Amp <sup>2</sup> -sec

#### Multiple stroke flash (cloud to ground strikes)

The model shall consist of 24 strokes randomly distributed within 2 seconds, with the following characteristics:

First Stroke -	Peak Amplitude, 200 KA
	Peak Rate of Rise, 140 KA/micro-second
	Action Integral, 2 x 10 <sup>6</sup> Amp <sup>2</sup> -sec.

Disclaimer – This document is not exhaustive and it will be updated gradually.



23 Strokes - Peak Amplitude, 50KA  
Peak Rate of Rise, 70KA/micro-second  
Action Integral, each 0.062 x 10<sup>6</sup> Amp<sup>2</sup> -sec.

Repetition rate between each stroke will be between 10 ms and 200 ms.

Multiple burst (cloud to cloud strikes)

The model used to assess the functional effects of the multiple burst shall consist of 24 sets of 20 strokes randomly distributed within 2 seconds, with the following characteristics:

- Peak Amplitude 10KA
- Peak Rate of Rise 200KA/Micro-second

Repetition rate between each of the 24 sets will be between 10 ms and 200 ms.

NOTE: While the detailed M.O.C. will need to be agreed with the AA, taking into account the effect on the aircraft, it should be noted that

- (i) Any combination of analysis and testing should be agreed with the JAA.
- (ii) For test results an extrapolation of the threat current parameters of more than a factor of 10 is not likely to be acceptable without an additional safety factor being applied.
- (iii) For a proven analysis technique, a safety factor of at least 2 will be required.

**Acronyms and Abbreviations**

<b>JAR</b>	Joint Aviation Regulation
<b>JAA</b>	Joint Aviation Authorities
<b>AA</b>	Aviation Authorities
<b>MOC</b>	Means of Compliance

Disclaimer – This document is not exhaustive and it will be updated gradually.



## S-10: EFFECT OF EXTERNAL RADIATION UPON AIRCRAFT SYSTEMS

<b>SPECIAL CONDITION</b>	<b>S-10: Effect of external radiation upon aircraft systems</b>
APPLICABILITY:	A330 / A340-200/-300
REQUIREMENTS:	JAR 25.1309(a) and (b), JAR 25.1431
ISSUE:	3 dated 24/04/1992

### Special Condition summary

#### BACKGROUND

Military experience has shown that radiated transmissions from civil or military stations may cause interference with critical flight systems (e.g. flight or engine controls), such as to cause system loss or malfunction which can hazard the aircraft.

Such ground transmission may be at varying power and frequency levels and may be produced by ground installations whose actual performance is secret.

The A330/340 aircraft models are equipped with computers that perform essential and critical functions that must be adequately protected against these external radiations.

#### SPECIAL CONDITION

- (a) Each system whose failure to function properly would prevent the continued safe flight and landing of the aircraft, must be designed and installed to ensure that the aeroplane operation is not affected during and after exposure to external radiations.
- (b) Each system whose failure to function properly would reduce the capability of the aircraft or the ability of the flight crew to cope with adverse operating conditions, must be designed and installed to ensure that it can perform its intended function after exposure to external radiations.

The external threat frequency bands and corresponding average and peak levels that shall be used for showing compliance with the above special condition are defined in the revised appendix to this CRI.

### APPENDIX TO CRI S-10

#### HIRF Environment (External radiations)

The HIRF Environment is a critical environment condition and is defined by the following Table in terms of field strength in volts per metre versus the given frequency range. This environment is based on the available data representing all known transmitters in the U.S. and the following contributing countries: United Kingdom, France, West Germany, The Netherlands and Sweden.

Disclaimer – This document is not exhaustive and it will be updated gradually.



Frequency	FIELD STRENGTH (Volts/meter)	
	PEAK	AVERAGE
10 kHz – 500 kHz	60	60
500 kHz – 2000 kHz	80	80
2 MHz – 30 MHz	200	200
30 MHz – 100 MHz	33	33
100 MHz – 200 MHz	150	33
200 MHz – 400 MHz	70	70
400 MHz – 1000 MHz	4020	935
1 GHz – 2 GHz	7850	1750
2 GHz – 4 GHz	6000	1150
4 GHz – 6 GHz	6800	310
6 GHz – 8 GHz	3600	666
8 GHz – 12 GHz	5100	1270
12 GHz – 18 GHz	3500	551
18GHz – 40GHz	2400	750

Note 1: At 10 kHz - impedance field of

Note 2: The detailed compliance for each agreed with JAA.

100 KHz, a high 320 V/M peak exists.

means of establishing system will need to be

### Acronyms and Abbreviations

<b>JAR</b>	Joint Aviation Regulation
<b>JAA</b>	Joint Aviation Authorities
<b>HIRF</b>	High Intensity Radiated Fields

Disclaimer – This document is not exhaustive and it will be updated gradually.





## S-10.1: EFFECT OF EXTERNAL RADIATION UPON AIRCRAFT SYSTEMS

<b>SPECIAL CONDITION</b>	<b>S-10.1: Effect of external radiation upon aircraft systems</b>
APPLICABILITY:	A330 / A340-200/-300
REQUIREMENTS:	JAR 25.1309(a) and (b), JAR 25.1431
ISSUE:	4 dated 24/02/1999

### Special Condition summary

#### BACKGROUND

When the A330/A340 was first certified, the normal HIRF environment was not defined. JAA INT POL 25/2, dated February 10, 1992, provides a more up to date definition for the certification HIRF environment and in addition, a normal HIRF environment is also provided.

This Special Condition S-10.1 will apply for new applications (new or modified aeroplane system and associated components) and supersede the SC-10..

#### SPECIAL CONDITION

The aeroplane systems and associated components, considered separately and in relation to other systems, must be designed and installed so that:

- (1) Each system that performs a critical or essential function is not adversely affected when the aeroplane is exposed to the Normal HIRF Environment.
- (2) All critical functions must not be adversely affected when the aeroplane is exposed to the Certification HIRF Environment.
- (3) After the aeroplane is exposed to the Certification HIRF environment, each affected system that performs a critical function recovers normal operation without requiring any crew action, unless this conflicts with other operational or functional requirements of that system.

The external threat frequency bands and corresponding average and peak levels that shall be used for showing compliance with the above special condition are defined in the following appendix.

Disclaimer – This document is not exhaustive and it will be updated gradually.



## APPENDIX TO CRI S-10.1

### Certification HIRF Environment

Frequency	FIELD STRENGTH (Volts/meter)	
	PEAK	AVERAGE
10 kHz – 100 kHz	40	40
100 kHz – 500 kHz	40	40
500 kHz – 2 MHz	40	40
2 MHz – 30 MHz	100	100
30 MHz – 70 MHz	20	20
70 MHz – 100 MHz	20	20
100 MHz – 200 MHz	50	30
200 MHz – 400 MHz	70	70
400 MHz – 700 MHz	730	30
700 MHz – 1 GHz	1300	70
1 GHz – 2 GHz	2500	160
2 GHz – 4 GHz	3500	240
4 GHz – 6 GHz	3200	280
6 GHz – 8 GHz	800	330
8 GHz – 12 GHz	3500	330
12 GHz – 18 GHz	1700	180

Note: At 10 kHz - 100 kHz a High Impedance Field of 320 V/m peak exists, AMJ 25.1317 should be referred to for the applicability of this environment.

### Normal HIRF Environment

Frequency	FIELD STRENGTH (Volts/meter)	
	PEAK	AVERAGE
10 kHz – 100 kHz	20	20
100 kHz – 500 kHz	20	20
500 kHz – 2 MHz	30	30
2 MHz – 30 MHz	50	50
30 MHz – 70 MHz	10	10
70 MHz – 100 MHz	10	10
100 MHz – 200 MHz	30	30
200 MHz – 400 MHz	25	25

Disclaimer – This document is not exhaustive and it will be updated gradually.



<b>Acronyms</b>	<b>and</b>	<b>400 MHz – 700 MHz</b>	<b>730</b>	<b>30</b>	<b>Abbreviations</b>
		<b>700 MHz – 1 GHz</b>	<b>40</b>	<b>10</b>	
		<b>1 GHz – 2 GHz</b>	<b>1700</b>	<b>160</b>	
		<b>2 GHz – 4 GHz</b>	<b>3000</b>	<b>170</b>	
		<b>4 GHz – 6 GHz</b>	<b>2300</b>	<b>280</b>	
		<b>6 GHz – 8 GHz</b>	<b>530</b>	<b>230</b>	
<b>JAR</b>	Joint Aviation Regulation				
<b>JAA</b>	Joint Aviation Authorities				
<b>HIRF</b>	High Intensity Radiated Fields				
<b>AMJ</b>	Advisory Material Joint				

Disclaimer – This document is not exhaustive and it will be updated gradually.



## S-10.2: EFFECT OF EXTERNAL RADIATION UPON AIRCRAFT SYSTEMS

<b>SPECIAL CONDITION</b>	<b>S-10.2: Effect of external radiation upon aircraft systems</b>
APPLICABILITY:	A330 / A340
REQUIREMENTS:	JAR 25.1309(a) and (b), JAR 25.1431
ISSUE	5 dated 14/02/2000

### Special Condition summary

#### BACKGROUND

When the A340 was first certified, the normal HIRF environment was not defined. CRI S10 at Issue 3 dated April 24, 1992 has covered the concerns and this is recorded as SC C10.

JAA INT POL 25/2 Issue 1, dated February 10, 1992, has provided an up-to-date definition for the certification HIRF environment and a normal HIRF environment. Based on this JAA interim policy, on February 24, 1999, CRI S10 has been reviewed and this has resulted in a new Special Condition SC S10.1. This revised SC10.1 superseded the initial SC 10 for the new applications (new or modified aeroplane system and associated components).

JAA are currently developing in co-operation with the FAA, a regulatory project for HIRF. This project is co-ordinated by the FAA/JAA Electromagnetic Effects Harmonization Working Group and relies heavily on work conducted by EUROCAE WG 33, in co-operation with SAE-AE4R.

The objective of the project is the issuance of an NPA (Notice of Proposed Amendment) in parallel with an FAA NPRM leading to a final rule and associated advisory material (Advisory Material Joint, and Users Guide).

In November 1998, the Electromagnetic Effects Harmonisation Working Group adopted a set of HIRF environment levels together with a proposed NPA/NPRM, which were agreed upon by the JAA, FAA and industry working group participants. As a result, the HIRF environments in the revised Interim Policy 25/2 at issue 2 reflect the environment levels recommended by this working group.

This Special Condition S-10.2 will apply for new applications (new or modified aeroplane system and associated components).

#### SPECIAL CONDITION

The aeroplane electrical and electronic systems, equipment, and installations considered separately and in relation to other systems must be designed and installed so that:

- A. Each function, the failure of which would prevent the continued safe flight and landing of the aeroplane:
- 1) Is not adversely affected when the aeroplane is exposed to the Certification HIRF environment defined in Appendix.

Disclaimer – This document is not exhaustive and it will be updated gradually.



- 2) Following aeroplane exposure to the Certification HIRF environment, each affected system that performs such a function automatically recovers normal operation unless this conflicts with other operational or functional requirements of that system.
- B. Each system that performs a function, the failure of which would prevent the continued safe flight and landing of the aeroplane, is not adversely affected when the aeroplane is exposed to the Normal HIRF environment defined in Appendix.
- C. Each system that performs a function, the failure of which would cause large reductions in the capability of the aeroplane or the ability of the crew to cope with adverse operating conditions, is not adversely affected when the equipment providing these functions is exposed to the equipment HIRF test levels defined in Appendix.
- D. Each system that performs a function, the failure of which would reduce the capability of the aeroplane or the ability of the crew to cope with adverse operating conditions, is not adversely affected when the equipment providing these functions is exposed to the equipment HIRF test levels in Appendix.

#### APPENDIX TO CRI S-10.2

Frequency	FIELD STRENGTH (V/m)	
	PEAK	AVERAGE
10 kHz – 100 kHz	50	50
100 kHz – 500 kHz	50	50
500 kHz – 2 MHz	50	50
2 MHz – 30 MHz	100	100
30 MHz – 70 MHz	50	50
70 MHz – 100 MHz	50	50
100 MHz – 200 MHz	100	100
200 MHz – 400 MHz	100	100
400 MHz – 00 MHz	700	50
700 MHz – 1 GHz	700	100
1 GHz – 2 GHz	2000	200
2 GHz – 4 GHz	3000	200
4 GHz – 6 GHz	2000	200
6 GHz – 8 GHz	Certification HIRF Environment	
8 GHz – 12 GHz	3000	300
12 GHz – 18 GHz	2000	200
18 GHz – 40 GHz	600	200

Frequency	FIELD STRENGTH (V/m)	
	PEAK	AVERAGE
10 kHz – 100 kHz	20	20
100 kHz – 500 kHz	20	20
500 kHz – 2 MHz	30	30
2 MHz – 30 MHz	100	100
30 MHz – 70 MHz	10	10
70 MHz – 100 MHz	10	10
100 MHz – 200 MHz	30	10
200 MHz – 400 MHz	10	10
400 MHz – 700 MHz	700	40
700 MHz – 1 GHz	700	40
1 GHz – 2 GHz	1300	160
2 GHz – 4 GHz	3000	120
4 GHz – 6 GHz	Normal HIRF Environment	
6 GHz – 8 GHz	1000	170
8 GHz – 12 GHz	1230	230
12 GHz – 18 GHz	730	190
18 GHz – 40 GHz	600	150

Disclaimer – This document is not exhaustive and it will be updated gradually.



---

## Acronyms and Abbreviations

<b>JAR</b>	Joint Aviation Regulation
<b>JAA</b>	Joint Aviation Authorities
<b>SC</b>	Special Condition
<b>HIRF</b>	High Intensity Radiated Fields
<b>FAA</b>	Federal Aviation Administration
<b>NPA</b>	Notice of Proposed Amendment
<b>NPRM</b>	New Proposal Rule Making

Disclaimer – This document is not exhaustive and it will be updated gradually.



## S-13: AUTO-THRUST SYSTEM

<b>SPECIAL CONDITION</b>	<b>S-13: Auto-thrust system</b>
APPLICABILITY:	A330 / A340
REQUIREMENTS:	JAR 25. 1141, JAR 25.1143, JAR 25.1329
ISSUE:	3 dated 02/10/1992

### Special Condition summary

## BACKGROUND

The A330 / A340 aircraft models are equipped with an Auto-Thrust System (ATS) for which additional requirements need to be considered.

## SPECIAL CONDITION

1. Disconnection of the ATS shall be by means of a quick release control readily useable by both pilots.
2. It must be possible to accomplish manual thrust control by means of a single pilot action.
3. Automatic disengagement of ATS shall be indicated by an appropriate aural warning.
4. Disconnection of the ATS and manual thrust control recovery shall not result in:
  - Significant disturbances in engine thrust, flight path or speed control;
  - Exceedance of engine limitations.
5. The ATS shall be compatible with the manual control including the manual flare.
6. The flight manual shall contain procedures for the ATS usage to ensure that failure conditions meet the requirements of JAR 25.1309 and its ACJ n°1 in the most adverse conditions (low visibility, wind, gust, wind shear, ...).
7. It must be shown by test and analysis that adequate cues are provided to the crew to monitor thrust changes and thrust values during normal auto-thrust operation.

## Acronyms and Abbreviations

<b>JAR</b>	Joint Aviation Regulation
<b>ATS</b>	Auto-Thrust System
<b>ACJ</b>	Advisory Circular Joint

Disclaimer – This document is not exhaustive and it will be updated gradually.



## S-16: CONTROL SIGNAL INTEGRITY

<b>SPECIAL CONDITION</b>	<b>S-16: Control Signal Integrity</b>
APPLICABILITY:	A330 / A340
REQUIREMENTS:	JAR 25.671, 699, 1309, 1431
ISSUE:	2 dated 31/10/1991

### Special Condition summary

#### BACKGROUND

On conventional aeroplanes transmission of control signals (flight controls, engine controls) was made through hydro-mechanical devices.

Determination of origin of perturbations to signal transmission was relatively straight forward since failure cases could usually be classified in a limited number of categories: maintenance error, jamming, disconnection or failure of mechanical elements or structural failure of hydraulic components. Therefore it was almost always possible to extract the most severe failure cases that would serve as an envelope to all other cases having the same consequence.

The JAR requirements are not adapted to fly by wire systems.

It is therefore necessary to amend them to introduce a more general requirement to cover integrity of signal transmission.

General experience on electrical digital transmission lines shows that perturbation of signal from internal and external sources is not unlikely.

In FBW systems, the occurrence of spurious signals coupling into the command signal loop may lead to unacceptable system response, with consequent flight hazards. Malfunctions could cause system instabilities, loss of function, or freeze-up of the control actuator. It is imperative that the command signal remain continuous. Hence, no command signal discontinuities shall be observed when sampling successive finite time intervals. Therefore, special design measures will be required to maintain the integrity of the FBW interfaces to a level of safety equivalent to that which is achieved with traditional hydro-mechanical designs.

#### SPECIAL CONDITION

Control and command signal transmission lines of Electrical control System must be designed and installed to provide adequate signal integrity and protection against unintentional alterations from internal or external sources.

#### Acronyms and Abbreviations

<b>JAR</b>	Joint Aviation Regulation
<b>FBW</b>	Fly By Wire

Disclaimer – This document is not exhaustive and it will be updated gradually.





## S-18: ELECTRICAL FLIGHT CONTROLS UNUSUAL FEATURES

<b>SPECIAL CONDITION</b>	<b>S-18: Electrical flight controls unusual features</b>
APPLICABILITY:	A330 / A340
REQUIREMENTS:	JAR 25.671
ISSUE:	2 dated 06/05/1991

### Special Condition summary

## BACKGROUND

A330/A340 aircraft models are equipped with an Electrical Flight Control System (EFCS). A special condition had been issued to address unusual features not addressed by JAR.

## SPECIAL CONDITION

Add to JAR 25.671 new paragraph (f)

(f) In case of abnormal attitude or excursion of any other flight parameter outside protected flight boundaries that might be reached due to external events :

- (i) The Electric Flight Control System (EFCS) shall continue to operate.
- (ii) The design of the EFCS control laws, including the automatic protection function, must, not hinder aircraft recovery.

## Acronyms and Abbreviations

<b>EFCS</b>	Electrical Flight Control System
<b>JAR</b>	Joint Aviation Regulation

Disclaimer – This document is not exhaustive and it will be updated gradually.



## S-20: EMERGENCY ELECTRICAL POWER

<b>SPECIAL CONDITION</b>	<b>S-20: Emergency Electrical Power</b>
APPLICABILITY:	A330 / A340
REQUIREMENTS:	JAR 25.1309, JAR 25.1351, JAR 25.1353, NPA 25D,F-179 rev 4
ISSUE:	4 dated 02/10/1992

### Special Condition summary

## BACKGROUND

The A330 / A340 aircraft models are using various computers performing critical and essential functions. The electrical power on such aircraft is more important than on conventional aircraft which can be operated without electrical power.

NPA 25D, F-179 (rev.4) has been issued to update the requirements concerning emergency electrical systems.

Taking into account the importance of the electrical system on the A330, this NPA will be applied as special condition.

## SPECIAL CONDITION

Replace entirely the existing text of JAR 25.1351 (d) with the following:

### (d) OPERATION WITHOUT NORMAL ELECTRICAL POWER

Unless it can be shown that the loss of the normal electrical power generating system(s) is extremely improbable, alternate, high integrity, electrical power system(s) independent of the normal electrical power generating system(s), must be provided to power those services necessary to complete a flight and make a safe landing.

(1) The services to be powered must include:

- (i) Those required for immediate safety and which must continue to operate, following the loss of the normal electrical power generating system(s) without the need for flight crew action.
- (ii) Those required for continued controlled flight.
- (iii) Those required for descent, approach and landing

And

(2) Failures, including junction box, control panel or wire bundle fires, which would result in the loss of the normal and alternate systems must be shown to be extremely improbable.

<b>JAR</b>	Joint Aviation Regulation
<b>NPA</b>	Notice of Proposed Amendment

Disclaimer – This document is not exhaustive and it will be updated gradually.



## S-21: BRAKES WEAR LIMITS

SPECIAL CONDITION	S-21: Brakes Wear Limits
APPLICABILITY:	A330/A340
REQUIREMENTS:	JAR 25.735
ISSUE:	5 dated 02/10/1992

### Special Condition summary

## BACKGROUND

This Special Condition introduces new requirements on brake wheel and tyre assembly demonstrating their capability to absorb the maximum kinetic energy corresponding to RTO (Rejected Take-Off) up to the wear limit authorized for the A330/A340.

## SPECIAL CONDITION

(a) Each brake must be approved and tested according to the appended annex. (See also ACJ 25.735(a))

(b) Each wheel and brake assembly must be provided with a means to indicate the limit of permitted wear. The means must be reliable and positioned for easy inspection.

## ANNEX TO SPECIAL CONDITION S-21 - BRAKES QUALIFICATION REQUIREMENTS

The brakes qualification requirements consist of the CAA specification 17 amended as follows:  
Replace par 4.2 of CAA spec 17 by the following:

### 4.2 Wheel and Brake assembly test

A sample of a wheel and brake assembly design, with a suitable tyre of proper fit installed, must meet the following tests to qualify the design for its kinetic energy ratings. The wheel of a wheel and brake assembly must be separately tested under paragraph 4.1. The wheel and brake assembly must be tested with the operating medium specified by the manufacturer.

### (A) Dynamic Tests

Test the wheel and brake assembly on a suitable inertial brake testing machine in accordance with the following:

(1) Speed and weight values. Select either method I or II below to calculate the kinetic energy level which a single wheel and wheel brake assembly will be required to absorb.

(i) Calculate the kinetic energy level to be used in the brake testing machine by using the equation:

$$KE = \frac{0.0443 * W * V^2}{N}$$

Disclaimer – This document is not

TE.CERT.00053-001 © European  
Proprietary document. Copies are

#### Where

**KE** = kinetic energy per wheel and brake assembly (ft. lb.);

**W** = design landing weight (lb.);

**V** = aeroplane speed in knots.

**V** must not be less than VSO the power off stalling speed of the aircraft at sea level, at the design landing weight and in the landing configuration. For the accelerate stop test applicable only to wheel-brake assemblies for aeroplanes certificated under JAR 25, the manufacturer must determine the most critical combination of take-off weight and speed.

**N** = number of main wheels with brakes.



(ii) Method II. The speed and weight values may be determined by other equations based on a rational analysis of the sequence of events expected to occur during the accelerate-stop manoeuvre or an operational landing at maximum landing weight. The analysis must include rational or conservative values for braking coefficients of friction between the tyre and runway, aerodynamic drag, propeller drag, power plant forward thrust and, if critical, loss of drag credit for the most adverse single-engine or propeller due to malfunction.

(2) Test Requirements

The wheel and brake assembly must bring the inertial testing machine to a stop at the average deceleration, and for the number of repetitions specified in table III without failure, impairment of operation, or replacement of parts except as permitted in paragraph 4.2(A)(3).

Table III

• :

Category of Aircraft	Test
JAR 25	<p>KE<sub>DL</sub> design landing stops</p> <ul style="list-style-type: none"> <li>• 100 design landing stop at a deceleration selected by manufacturer but not less than 10 ft/s<sup>2</sup>.</li> <li>• KE<sub>RT</sub> 1 accelerate-stop at a deceleration selected by the manufacturer to be representative of the Flight Manual scheduled accelerates stop data but not less than 6 ft/s<sup>2</sup>.</li> </ul>

(3) General Conditions

During landing stop tests (KE<sub>DL</sub>), one change of brake lining is permissible. The remainder of the brake assembly parts must withstand the 100 KE<sub>DL</sub> stops without failure or impairment of operation.

(4) Accelerate Stop Test (KE<sub>RT</sub>)

(i) The brake, wheel and tyre assembly must be capable of absorbing the accelerate stop test energy KE<sub>RT</sub> throughout the entire defined usable wear range of the heat sink elements (as determined by the means provided to comply with E.2.(3a). Compliance must be shown by an accelerate stop test (KE<sub>RT</sub>) carried out on a brake in which the usable wear range of the heat sink has been fully consumed (100%). For this test, no allowance may be made for the decelerating effects of available powerplant thrust reversers.

At the commencement of the test the temperature of the brake should be representative of the following combined conditions:

1. Maximum permissible temperature for dispatch from the ramp.

Disclaimer – This document is not exhaustive and it will be updated gradually.



2. Energy input to the brake as a result of braking during taxiing, up to the point of brakes release for take-off.

Note: For the purpose of this test an arbitrary value of 10 percent of  $KE_{RT}$  would be acceptable to the JAA.

However, the applicant may choose to submit a value based on a more rational analysis.

(ii) The applicant shall define the tyre nominal loaded radius and the relative load rating and inflation pressure used for the tyre, wheel and brake during the test.

(iii) The applicant shall determine the amount of energy absorbed by the tyre, wheel and brake individually during the test.

(iv) After the test the brake must continue to be functional for taxiing and allow the wheel to rotate freely with the brake selected off. There should be no failure which would result in fluid leakage or fire.

(v) If so desired it will be permissible in performing the test for the brake pressure to be released at a speed less than 10 knots in order to simulate a taxi roll sufficient to clear the runway, provided that the capability to have stopped the aircraft within the scheduled distance can be extrapolated from the test record and also that at the end of such a taxi roll the brake is still capable of bringing the wheel to a stop from whatever taxiing speed is used on the test machine.

### **(B) Brake Structural Torque Test.**

Apply load  $S$  and a torque load specified in paragraph 4.2 (B) (1) or (2) as applicable, for at least 3 seconds. Rotation of the wheel must be resisted by a reaction force transmitted through the brake or brakes by an application of at least maximum brake line pressure or maximum brake cable tension in the case of a mechanically operated brake. If such pressure or tension is insufficient to prevent rotation, the friction surface may be clamped, bolted, or otherwise restrained while applying the pressure or tension.

(1) For landing gears with only one wheel per landing gear strut, the torque load is  $1.2 SR$ , where  $R$  is the normal loaded radius of the tyre at rated inflation pressure under load  $S$ .

(2) For landing gears with multiple wheels per landing gear strut, the torque load is  $1.44 SR$  where  $R$  is the normal loaded radius of the tyre at rated inflation pressure under load  $S$ .

### **(C) Overpressure-Hydraulic Brakes**

The brake with actuator piston extended to simulate a maximum worn condition must withstand hydraulic pressure for at least 3 seconds, equal to 2 times the maximum brake line pressure available to the brakes.

### **(D) Endurance Tests - Hydraulic Brakes**

Disclaimer – This document is not exhaustive and it will be updated gradually.



The hydraulic brake assembly must be subjected to an endurance test during which the total leakage may not exceed 5cc and no malfunction may occur during or upon completion of the test. Minimum piston travel during the test may not be less than the maximum allowable piston travel in operation. The tests must be conducted by subjecting the hydraulic brake assembly to:

(1) 100.000 cycles, of application and release of the average hydraulic pressure needed in the  $KE_{DL}$  tests specified in paragraph 4.2(A)(2) except that manufacturers using the method specified in paragraph 4.2(A)(2) must subject the wheel and brake assembly to the average of the maximum pressures needed in those tests. The piston must be adjusted so that 25.000 cycles are performed at each of the four positions where the piston would be at rest when adjusted for 25, 50, 75, and 100 percent of the wear limit; and

(2) 5.000 cycles at the maximum system pressure available to the brakes.

### Acronyms and Abbreviations

<b>CAA</b>	Civil Aviation Authority
<b>JAR</b>	Joint Aviation Regulation
<b>ACJ</b>	Advisory Circular Joint
<b>RTO</b>	Rejected Take-off

Disclaimer – This document is not exhaustive and it will be updated gradually.



## S-23: MISCELLANEOUS ELECTRICAL REQUIREMENTS

<b>SPECIAL CONDITION</b>	<b>S-23: Miscellaneous electrical requirements</b>
APPLICABILITY:	A330 / A340
REQUIREMENTS:	JAR 25.1309, 25.1351, 25.1353, 25.1359, NPA 25DF-191 Rev. 2
ISSUE:	6 dated 07/02/1993

### Special Condition summary

## BACKGROUND

Some requirements amendments introduced by NPA 25DF-191 have been considered sufficiently important to be applied to the A340 as special condition:

## SPECIAL CONDITION

1. Amend the cross reference of JAR 25.1309(b) as follows:

(b) The aeroplane systems and associated components, considered separately and in relation E to other systems, must be designed so that (see AMJ 25.1309 and ACJN (No.3 to JAR25.1309 and AMJ25.1309(b))

2. Amend JAR 25.1351(b)(5) to read:

(5) There are means accessible where necessary, in flight, to appropriate crew members for the individual and rapid disconnection of each electrical power source. (See ACJ 25.1351 (b)(5)).

3. Amend JAR 25.1353(d) to read:

(d) Electrical cables and cable installations must be designed and installed as follows:

(1) The electrical cables used must be compatible with the circuit protection devices required-by JAR 25.1357 such that a fire or smoke hazard cannot be created under temporary or continuous fault conditions.

(2) Means of permanent identification must be provided for electrical cables, connectors and terminals.

(3) Electrical cables must be installed such that the risk of mechanical damage and/or damage caused by fluids, vapours or sources of heat, is minimised. )

4. Amend JAR 25.1359(d) to read:

Disclaimer – This document is not exhaustive and it will be updated gradually.



(d) Insulation on electrical wire and electrical (cable installed in any area of the aeroplane must be self-extinguishing when tested at an angle of 60° in accordance with the applicable portions of Appendix F or other approved equivalent methods. The average burn length may not exceed 3 inches and the average flame time after removal of the flame source may not exceed 30 seconds. Drippings from the test specimen may not continue to flame for more than an average of 3 seconds after falling.

5. Add a cross reference to JAR 25X1362 as follows:

**JAR 25x1362 Electrical supplies for emergency conditions**

A suitable supply must be maintained to those services which are required, either by this JAR-25 (e.g. JAR 25.1195) or in order that emergency landing or ditching. The circuits to these services must be so designed and protected that the risk of their causing a fire under these conditions is minimised (See ACJ25X1362).

6. Amend JAR 25.1363 to read:

**JAR 25.1363 Electrical system tests**  
(See ACJ25X1363)

(a) Tests must be made to determine that the performance of the electrical supply systems meets the requirements of this JAR-25 under all the appropriate normal and failure conditions. When laboratory tests of the electrical system are conducted –

7. Add a new subparagraph (d) to JAR 25.1431 reading:

(d) Electronic equipment must be designed and installed such that it does not cause essential loads to become inoperative, as a result of electrical power supply transients or transients from other causes.

**Acronyms and Abbreviations**

<b>JAR</b>	Joint Aviation Regulation
<b>NPA</b>	Notice of Proposed Amendment
<b>ACJN</b>	
<b>AMJ</b>	Advisory Material Joint
<b>ACJ</b>	Advisory Circular Joint

Disclaimer – This document is not exhaustive and it will be updated gradually.





## S-24: DOORS

<b>SPECIAL CONDITION</b>	<b>S-24: Doors</b>
APPLICABILITY:	A330 / A340
REQUIREMENTS:	JAR 25.783
ISSUE:	2 dated 03/06/1991

### Special Condition summary

## BACKGROUND

Paragraph 783 of the JAR code is identical to the corresponding FAR paragraph.

Following the needs to provide clarification and to cope with some printing errors which have been crept into the published code, this Special condition has been created.

## SPECIAL CONDITION

- 1) Modify JAR 25.783(g) to read:  
Cargo and service doors not suitable for use as an exit in an emergency need only meet subparagraph (e) and (f) of this paragraph and be safeguarded against opening in flight as a result of mechanical failure or failure of a single structural element.
- 2) Subparagraphs (b), (c), (d) of JAR 25.783 are only applicable to doors suitable as an exit in an emergency.

## Acronyms and Abbreviations

<b>JAR</b>	Joint Aviation Regulation
<b>FAR</b>	Federal Aviation Regulations

Disclaimer – This document is not exhaustive and it will be updated gradually.



## S-38: TOWBARLESS TOWING

<b>SPECIAL CONDITION</b>	<b>S-38: Towbarless towing</b>
APPLICABILITY:	A330 / A340
REQUIREMENTS:	JAR 25X745(d)
ISSUE:	5 dated 22/10/1999

### Special Condition summary

## BACKGROUND

The design of the nose landing gear incorporates means to preclude damage to the steering system in the event that loads induced in the steering system by conventional towbar towing activities approach the capability of the design to withstand the loads. Airbus is intending to give approval to other methods of towing the aeroplane, typically referred to as "Towbarless Towing" which utilise means which do not connect to the aeroplane nose landing gear via the protection device installed to ensure compliance with the requirement.

PNPA25D-275 is an acceptable alternative to the requirement JAR 25X745(d) and Airbus is requested to demonstrate compliance with PNPA25D-275 issue 1 rev 1 which is the basis of Special Condition S-38.

## SPECIAL CONDITION

Delete the entire text of the current paragraph JAR 25X745(d) and replace with the following:

### JAR 25X745 (d) Nose-Wheel Steering

(d) (see ACJ 25X745(d)) The nose wheel steering system, towing attachment(s), and associated elements must be designed or protected by appropriate means such that during ground manoeuvring operations effected by means independent of the aeroplane:

- (1) Damage affecting the safe operation of the nose wheel steering system is precluded, or
- (2) A flight crew alert is provided, before the start of taxiing, if damage may have occurred. (see AMJ 25.1322)

## Acronyms and Abbreviations

<b>JAR</b>	Joint Aviation Regulation
<b>ACJ</b>	Advisory Circular Joint
<b>AMJ</b>	Advisory Material Joint
<b>PNPA</b>	Preliminary Notice Per Amendment

Disclaimer – This document is not exhaustive and it will be updated gradually.



## S-45: OIL TEMPERATURE INDICATION

Equivalent Safety Finding	S-45: Oil temperature indication
APPLICABILITY:	A330 / A340
REQUIREMENTS:	JAR 25.1549(a)
ISSUE:	1 dated 18/06/1996

### Equivalent Safety Finding summary

#### BACKGROUND

The A330 / A340 engine oil temperature is displayed on the ECAM (Electronic Centralised Aircraft Monitoring) CRT. The indication is provided in digital form:

- it is normally green
- it pulses green if the temperature exceeds 160°C,
- it turns amber if the temperature exceeds 160°C for more than 15 minutes or the maximum oil temperature indicated by the engine manufacturer without delay

JAR 25.1549(a) requires that each maximum safe operating limit must be marked with a red radial or a red line.

Although written for conventional indicators, this has been generally applied to digital CRT indications by using a colour coding consistent with the conventional indicators.

The Airbus Oil temperature indication on ECAM therefore does not literally comply with JAR 25.1549(a), which would require the indication to turn red instead of amber when the maximum limit is exceeded.

#### CONCLUSION

The Equivalent Safety Finding is considered that the current design provide to the crew an unmistakable indication to the crew in case of maximum oil temperature exceedance, consistent with the degree of urgency of the required action (immediate awareness and subsequent action).

#### Acronyms and Abbreviations

<b>CRT</b>	Cathode Ray Tube
<b>ECAM</b>	Electronic Centralised Aircraft Monitoring
<b>ESF</b>	Equivalent Safety Finding
<b>JAR</b>	Joint Aviation Regulation

Disclaimer – This document is not exhaustive and it will be updated gradually.



## S-48: MINIMUM APPROACH BREAK-OFF HEIGHT

SPECIAL CONDITION Equivalent Safety Finding	S-48: Minimum Approach Break-off Height
APPLICABILITY:	A330 / A340
REQUIREMENTS:	JAR-AWO 313, 314, 316, 381- NPA AWO 8
ISSUE:	2 dated 25/08/1997

### Special Condition summary

#### BACKGROUND

The JAR AWO Change 1 requires that a Minimum Approach Break-off Height (MABH) be established. The MABH is the altitude at which the probability of contacting the runway during go-around is one in ten thousand. The operational Decision Height can be no lower than the MABH. JAR AWO 313 implies that contacting the runway during a go-around, in low visibility conditions, is unsafe.

The FAA has no requirement for a MABH but relies on a demonstration of a safe go-around from any altitude down to touch down.

Agreement was reached in the JAA/FAA harmonisation group that, since aeroplane systems are required by JAR AWO 316 to demonstrate that a safe go-around can be accomplished from any point to touch down, the MABH concept can be removed from JAR AWO without detriment to safety of operation. In its place, information would be included in the approved flight manual giving go-around height loss information on which operational decision height, if required, can be based.

In the frame of the JAR/FAR harmonization, the JAR AWO working group has developed NPA AWO 8 which replace MABH requirements.

#### SPECIAL CONDITION

The original JAR AWO requirements listed below have to be modified as follow:

*JAR AWO subpart 3, page 3-3: Delete the definition of MABH*

*Delete JAR-AWO 313*

*JAR-AWO 314: Delete the first sentence such that the paragraph reads "when the decision height is during ... place".*

*JAR-AWO 316: Go-around*

*Add "(see ACJ AWO 316)" to the title.*

*JAR-AWO 316(a): revise to read:*

Disclaimer – This document is not exhaustive and it will be updated gradually.



---

*"The aircraft must be capable of safely executing a go-around from any point on the approach to touchdown in all configurations to be certificated. The manoeuvre may not require exceptional piloting skill...Category II or III"*

*JAR-AWO 381: Aeroplane flight manual (general)*

*Add a new paragraph (f):*

*"(f) The height losses for go-around initiation heights below 100 ft. determined in accordance with ACJ AWO 316 paragraph 2a."*

### **Acronyms and Abbreviations**

<b>JAR</b>	Joint Aviation Regulation
<b>AWO</b>	All Weather Operations
<b>MABH</b>	Minimum Approach Break-off Height
<b>FAA</b>	Federal Aviation Administration
<b>JAA</b>	Joint Aviation Authorities

Disclaimer – This document is not exhaustive and it will be updated gradually.



**S-148: LONGITUDINAL TOUCHDOWN PERFORMANCE LIMIT AND MINIMUM APPROACH BREAK-OFF HEIGHT**

<b>SPECIAL CONDITION Equivalent Safety Finding</b>	<b>S-148: Longitudinal touchdown performance limit and Minimum Approach Break-off Height</b>
APPLICABILITY:	A330 / A340
REQUIREMENTS:	JAR AWO 131, 313, 314, 316, 381- NPA AWO 8
ISSUE:	2 dated 04/08/1998

**Special Condition summary**

**BACKGROUND**

In the frame of A330 / A340, Airbus Industrie has elected to comply with JAR NPA AWO-8. This NPA addresses the following JAR / FAA AWO harmonization items:

- Longitudinal touchdown performance limit (proposal n°1)
- Revised strategy for demonstrating a safe go-around (proposal n°2)

The longitudinal touchdown performance limit for automatic landing differs between current FAA and JAA requirements, with the FAA requirement being more severe. The end of the touchdown box for the current JAA requirement is 3,000 feet from the runway threshold.

The JAR AWO Change 1 requires that a Minimum Approach Break-off Height (MABH) be established. The MABH is the altitude at which the probability of contacting the runway during go-around is one in ten thousand. The operational Decision Height can be no lower than the MABH JAR AWO 313 implies that contacting the runway during a go-around, in low visibility conditions, is unsafe.

The FAA has no requirement for a MABH but relies on a demonstration of a safe go-around from any altitude down to touchdown.

Agreement has been reached in the JAA / FAA AWO Harmonisation Working Group that since aeroplane systems are required by JAR AWO 316 to demonstrate that a safe go-around can be accomplished from any point to touchdown, the MABH concept can be removed from JAR AWO without detriment to safety of operation. In its place, information would be included in the approved flight manual giving go-around height loss information on which operational decision height, if required can be based.

In the frame of the JAR FAR harmonization, the JAA AWO working group has developed JAR NPA AWO-8 which replace MABH requirement.

**SPECIAL CONDITION**

The original JAR AWO requirements listed below have to be modified as follow:

Disclaimer – This document is not exhaustive and it will be updated gradually.



*Revise JAR-AWO 131(c)(2) by deleting the limit 900 m (3,000 ft.) and substituting 823 m (2,700 ft).*

*JAR AWO subpart 3, page 3-3: Delete the definition of MABH.*

*Delete JAR-AWO 313*

*JAR-AWO 314: Delete the first sentence such that the paragraph reads "When the decision height is during ... place."*

*JAR-AWO 316: Go-around*

*Add "(see ACJ AWO 316)" to the title.*

*JAR-AWO 316(a): revise to read:*

*"The aircraft must be capable of safely executing a go-around from any point on the approach to touchdown in all configurations to be certificated. The manoeuvre may not require exceptional piloting skill... Category II or III"*

*JAR-AWO 381: Aeroplane Flight Manual (General)*

*Add a new paragraph (t):*

*"(t) The height losses for go-around initiation heights below 100 ft. determined in accordance with ACJ AWO 316 paragraph 2a.*

## **Acronyms and Abbreviations**

<b>JAR</b>	Joint Aviation Regulation
<b>AWO</b>	All Weather Operations
<b>DEV</b>	Deviation
<b>MABH</b>	Minimum Approach Break-off Height
<b>NPA</b>	Notice of Proposed Amendment
<b>FAA</b>	Federal Aviation Administration

Disclaimer – This document is not exhaustive and it will be updated gradually.



## S-1013: AUTO-THRUST SYSTEM (ATS)

<b>SPECIAL CONDITION</b>	<b>S-1013: Auto-thrust System (ATS)</b>
APPLICABILITY:	A340-500/-600
REQUIREMENTS:	JAR 25.1329, JAR 25.1141, JAR 25.1143
ISSUE:	2 dated 10/08/2000

### Special Condition summary

## BACKGROUND

This Special Condition takes into account the following regulatory evolutions. Applicability of AMJ 25.1309 instead of ACJ n°1 to JAR 25.1309, adaptation for ATS of JAR 25.1329(i) at change 14 plus Orange Paper 96/1.

## SPECIAL CONDITION

1. Disconnection of the ATS shall be by means of a quick release control readily usable by both pilots.
2. It must be possible to accomplish manual thrust control by means of a single pilot action.
3. Automatic disengagement of ATS shall be indicated by an appropriate aural warning.
4. An alert must be provided to each pilot in the event of a manual disengagement of ATS.
5. Disconnection of the ATS and manual thrust control recovery shall not result in :
  - Significant disturbances in engine thrust, flight path or speed control ;
  - Exceedance of engine limitations.
6. The ATS shall be compatible with the manual control including the manual flare.
7. The flight manual shall contain procedures for the ATS usage to ensure that failure conditions meet the requirements of JAR 25.1309 and AMJ 25.1309 in the most adverse conditions (low visibility, wind, gust, windshear, etc...).
8. It must be shown by test and analysis that adequate cues are provided to the crew to monitor thrust changes and thrust values during normal auto-thrust operation.

## Acronyms and Abbreviations

<b>AMJ</b>	Advisory Material Joint
<b>ACJ</b>	Advisory Circular Joint
<b>ATS</b>	Auto-Thrust System

Disclaimer – This document is not exhaustive and it will be updated gradually.





## S-1021: BRAKES AND BRAKING SYSTEM

<b>SPECIAL CONDITION Equivalent Safety Finding</b>	<b>S-1021: Brakes and Braking System</b>
APPLICABILITY:	A340-500/-600
REQUIREMENTS:	JAR 25.731, 25.735
ISSUE:	3 dated 19/01/2006

### Special Condition summary

#### BACKGROUND

For basic A340 aircraft models, Special Condition S-21 was issued to introduce a requirement for maximum brake kinetic energy corresponding to a rejected take-off, up to the maximum brake wear limit authorized. This Special Condition was issued as an equivalent safety finding, as it was associated to Special Condition F8 - Accelerate-stop distances, which was based on a past version of NPA 25BDG244.

For A340-500/-600, Special Condition F-1008 introduces the last version of NPA 25BDG244 (final rule issue June 1997, introduced in JAR 25 Change 15), on an elect to comply basis. In addition to the changes within subpart B and G, this final rule incorporates changes to JAR 25.735 - Brakes, which have not been retained within Special Condition F-1008, because Airbus Industrie has announced their intent to apply a more recent standard for wheels and brakes requirement, based on published NPA 25D-291.

#### SPECIAL CONDITION

##### 1. ADD THE FOLLOWING TWO NEW SUB-PARAGRAPHS (D) AND (E) TO JAR 25.731.

##### JAR 25.731 Wheels

##### **25.731(d) Overpressure burst prevention**

Means must be provided in each wheel to prevent wheel failure and tyre burst that may result from excessive pressurisation of the wheel and tyre assembly.

##### **25.731(e) Braked Wheels**

Each braked wheel must meet the applicable requirements of JAR 25.735.

##### 2. REPLACE JAR 25.735 WITH THE FOLLOWING, WHICH IS DERIVED FROM NPA 25D-291 (JULY 1998 VERSION).

##### JAR 25.735 Brakes & Braking Systems

Disclaimer – This document is not exhaustive and it will be updated gradually.



### 25.735 (a) Approval

Each assembly, consisting of a wheel(s) and brake(s), must be approved. **Wheel and Brake Qualification compliance shall be demonstrated in accordance with (J)TSO C-135.**

### 25.735 (b) Brake System Capability.

The brake system, associated systems and components must be designed and constructed so that:

- (1) If any electrical, pneumatic, hydraulic or mechanical connecting or transmitting element fails, or if any single source of hydraulic or other brake operating energy supply is lost, it is possible to bring the aeroplane to rest with a braked roll stopping distance of not more than two times that obtained in determining the landing distance as prescribed in JAR 25.125.
- (2) Fluid lost from a brake hydraulic system, following a failure in, or in the vicinity of, the brakes, is insufficient to cause or support a hazardous fire on the ground or in flight.

### 25.735(c) Brake Controls.

The brake controls must be designed and constructed so that: -

- (1) Excessive control force is not required for their operation
- (2) If an automatic braking system is installed, means are provided to arm and disarm the system, and
  - (ii) Allow the pilots to override the system by use of manual braking

### 25.735 (d) Parking Brake

The aeroplane must have a parking brake control that, when selected on, will without further attention, prevent the aeroplane from rolling on a dry and level paved runway when the most adverse combination of maximum thrust on one engine and up to maximum ground idle on any, or all, other engine(s) is applied. The control must be suitably located or be adequately protected to prevent inadvertent operation. There must be indication in the cockpit when the parking brake is not fully released”.

### 25.735 (e) Antiskid System

If an anti-skid system is installed:

- (1) It must operate satisfactorily over the range of expected runway surface conditions, without external adjustment
- (2) It must, at all times, have priority over the automatic braking system, if installed.

### 25.735 (f) Kinetic Energy Capacity

The design landing stop, the maximum kinetic energy accelerate-stop, and the most severe (**i.e. overweight and overspeed**) landing stop brake kinetic energy absorption requirements of each wheel and brake assembly must be determined. It must be substantiated by dynamometer testing that, at the declared fully worn limit(s) of the brake heat sink, the wheel and brake assemblies are capable of absorbing not less than these levels of kinetic energy. Energy absorption rates defined by the aeroplane manufacturer must be achieved. These rates must be equivalent to mean decelerations not less than 10ft/s<sup>2</sup> for the design landing stop and 6ft/s<sup>2</sup> for the maximum kinetic energy accelerate-stop.

The design landing stop is an operational landing stop at maximum landing weight.

Disclaimer – This document is not exhaustive and it will be updated gradually.



The maximum kinetic energy accelerate-stop is a rejected take-off at the most critical combination of aeroplane take-off weight and speed.

The most severe landing stop **cases that will be considered for A340-500/-600 are the overweight and overspeed landing stop cases.** This is a stop at the most critical combination of aeroplane landing weight and speed. The most severe landing stop need not be considered for extremely improbable failure conditions or if the maximum kinetic energy accelerate-stop energy is more severe.

**The overweight and overspeed landing stop cases that will be considered for A340-500/-600 are shown on the following matrix:**

	<u>Flaps &amp; Slats Used</u>	<u>Aircraft "Clean"</u>
<u>MTOW-1.1%</u>	<u>✓=Overweight Landing</u>	<u>✗=Not considered</u>
<u>MLW</u>	<u>✓=Design Landing Stop</u>	<u>✓=Overspeed Landing</u>

### **25.735 (g) Brake condition after high kinetic energy dynamometer stop(s)**

Following the high kinetic energy stop demonstration(s) required by sub-paragraph (f) of this paragraph, with the parking brake promptly & fully applied for at least three (3) minutes, it must be demonstrated that for at least five (5) minutes from application of the parking brake, no condition occurs (or has occurred during the stop), including fire associated with the tyre or wheel and brake assembly, that could prejudice the safe and complete evacuation of the aeroplane.

### **25.735 (h) Stored energy systems**

An indication to the flight crew of usable stored energy must be provided if a stored energy system is used to show compliance with sub-paragraph (b)(1) of this paragraph.

The available stored energy must be sufficient for:

- (1) At least six (6) full applications of the brakes when an anti-skid system is not operating, and
- (2) Bringing the aeroplane to a stop when an anti-skid system is operating, under all runway surface conditions for which the aeroplane is certificated.

### **25.735 (i) Brake Wear Indicators**

Means must be provided for each brake assembly to indicate when the heat sink is worn to the permissible limit. The means must be reliable and readily visible”

### **25.735 (j) Over temperature burst prevention**

Means must be provided in each braked wheel to prevent wheel failure and tyre burst that may result from elevated brake temperatures. Additionally, all wheels must meet the requirements of JAR 25.731(d).

### **25.735(k) Compatibility**

Compatibility of the wheel and brake assemblies with the aeroplane and its systems must be substantiated.

Disclaimer – This document is not exhaustive and it will be updated gradually.



---

## Acronyms and Abbreviations

<b>JTSO</b>	Joint Technical Service Order
<b>JAR</b>	Joint Aviation Regulation
<b>NPA</b>	Notice of Proposal Amendment

Disclaimer – This document is not exhaustive and it will be updated gradually.



## S-1059: HYDRAULIC SYSTEMS

Equivalent Safety Finding	S-1059: Hydraulic Systems
APPLICABILITY:	A340-500/-600
REQUIREMENTS:	JAR 25.1435
ISSUE:	2 dated 28/09/2000

### Equivalent Safety Finding summary

#### BACKGROUND

NPA 25F273, after publication in August 1996, went through comment within JAA and FAA (NPRM 96-6 and notice of availability of AC 25.1435-1). These comments have been addressed by the Hydraulics Harmonisation Working Group within a final comment/response document dated October 1998, including a revised proposal for JAR 25.1435 and AMJ 25.1435.

The JAA team considers that the final proposal dated October 1998 is acceptable for inclusion in A340-500/-600 JAA Type Certification Basis, on the basis of an equivalent safety level with JAR 25.1435.

It is therefore proposed to apply Special Condition SC S-1059 as part of A340-500/-600 JAA Type Certification Basis.

#### EQUIVALENT SAFETY FINDING

**Modify JAR 25.1435 to read as follows:**

#### 25.1435 Hydraulic Systems (See AMJ 25.1435)

##### (a) Element design

Each element of the hydraulic system must be designed to:

- (1) Withstand the proof pressure without permanent deformation that would prevent it from performing its intended function, and the ultimate pressure without rupture. The proof and ultimate pressures are defined in terms of the design operating pressure (DOP) as follows:

	Element	Proof (x DOP)	Ultimate (x DOP)
1.	Tubes and fittings	1.5	3.0
2.	Pressure vessels containing gas		
	High pressure (e.g. accumulators)	3.0	4.0
	Low pressure (e.g. reservoirs)	1.5	3.0
3.	Hoses	2.0	4.0
4.	All other elements	1.5	2.0

Disclaimer – This document is not exhaustive and it will be updated gradually.



- (2) Withstand, without deformation that would prevent it from performing its intended function, the design operating pressure in combination with limit structural loads that may be imposed;
- (3) Withstand, without rupture, the design operating pressure multiplied by a factor of 1.5 in combination with ultimate structural loads that can reasonably occur simultaneously;
- (4) Withstand the fatigue effects of all cyclic pressures, including transients, and associated externally induced loads, taking into account the consequences of element failure; and
- (5) Perform as intended under all environmental conditions for which the aeroplane is certificated.

**(b) System design**

Each hydraulic system must:

- (1) Have means located at a flight crew member station to indicate appropriate system parameters if,
  - (i) It performs a function necessary for continued safe flight and landing; or
  - (ii) In the event of hydraulic system malfunction, corrective action by the crew to ensure continued safe flight and landing is necessary;
- (2) Have means to ensure that system pressures, including transient pressures and pressures from fluid volumetric changes in elements that are likely to remain closed long enough for such changes to occur, are within the design capabilities of each element, such that they meet the requirements defined in JAR 25.1435(a)(1) to JAR 25.1435(a)(5) inclusive;
- (3) Have means to minimise the release of harmful or hazardous concentrations of hydraulic fluid or vapours into the crew and passenger compartments during flight;
- (4) Meet the applicable requirements of JAR 25.863, 25.1183, 25.1185 and 25.1189 if a flammable hydraulic fluid is used; and
- (5) Be designed to use any suitable hydraulic fluid specified by the aeroplane manufacturer, which must be identified by appropriate markings as required by JAR 25.1541.

**(c) Tests**

Tests must be conducted on the hydraulic system(s), and/or subsystem(s) and element(s), except that analysis may be used in place of or to supplement testing where the analysis is shown to be reliable and appropriate. All internal and external influences must be taken into account to an extent necessary to evaluate their effects, and to assure reliable system and element functioning and integration. Failure or unacceptable deficiency of an element or system must be corrected and be sufficiently retested, where necessary.

- (1) The system(s), subsystem(s), or element(s) must be subjected to performance, fatigue, and endurance tests representative of aeroplane ground and flight operations.

Disclaimer – This document is not exhaustive and it will be updated gradually.



- 
- (2) The complete system must be tested to determine proper functional performance and relation to other systems, including simulation of relevant failure conditions, and to support or validate element design.
- (3) The complete hydraulic system(s) must be functionally tested on the aeroplane in normal operation over the range of motion of all associated user systems. The test must be conducted at the relief pressure or 1.25 times the DOP if a system pressure relief device is not part of the system design. Clearances between hydraulic system elements and other systems or structural elements must remain adequate and there must be no detrimental effects.

### Acronyms and Abbreviations

<b>AMJ</b>	Advisory Material Joint
<b>DOP</b>	Design Operating Pressure
<b>ESF</b>	Equivalent Safety Finding
<b>NPA</b>	Notice of Proposed Amendment
<b>SC</b>	Special Condition
<b>JAA</b>	Joint Aviation Authorities
<b>FAA</b>	Federal Aviation Administration
<b>JAR</b>	Joint Aviation Regulation

Disclaimer – This document is not exhaustive and it will be updated gradually.



## S-1065: PACKS OFF OPERATION

Equivalent Safety Finding	S-1065: Packs off Operation
APPLICABILITY:	A340-500/-600
REQUIREMENTS:	JAR 25.831(a)
ISSUE:	2 dated 11/12/2001

### Equivalent Safety Finding summary

## BACKGROUND

### JAR 25.831(a) states:

Each passenger and crew compartment must be ventilated and each crew compartment must have enough fresh air (but not less than 10 cubic feet per minute per crew member) to enable crew members to perform their duties without undue discomfort or fatigue. (See ACJ 25.831(a)).

Taking into consideration that there are some air-conditioning packs off operation periods (i.e., at take-off, no fresh air for crew members) for the Model A340-500/-600, an equivalent safety finding to JAR 25.831(a) is required.

## CONCLUSION

An equivalent safety finding may be used for showing compliance to § 25.831a provided the following is considered:

1. There must be a means to annunciate to the flight crew that the pressurisation system (conditioned air supply) is selected off.
2. The Equivalent Safety Finding must document that the ventilation system continues to provide an acceptable environment in the passenger cabin and cockpit for the brief period when the pressurisation system is not operating. The degradation of crewmember air quality must not reach the level that would cause undue discomfort and fatigue to the point that it could affect the performance of their duties.
3. Furthermore, equipment environment should be evaluated during those short periods to ensure equipment reliability and performance are not impaired. This evaluation should cover the extremes of ambient hot air temperatures in which the airplane is expected to operate.
4. In addition, no unsafe condition due to limited packs-off operation would result, should a compartment fire occur. Criteria that should be considered include;
  - (a) Packs-on operation will not allow any smoke from the cargo compartment to penetrate the passenger compartment; and

Disclaimer – This document is not exhaustive and it will be updated gradually.





(b) During limited duration packs-off operation the cargo compartment smoke detection system is effective and the AC packs can be turned on and returned to the approved packs-on configuration to exclude hazardous quantities of smoke.

5. Finally, the air conditioning packs-off operation is intended to be a short duration operation. Therefore, the maximum period of operation in this configuration should be defined by the applicant and specified in the AFM, along with any related operating procedures necessary to maintain compliance with the regulatory issues discussed above.

An example of establishing “the maximum period of operation (short duration) for take-off”, would be an operational phase beginning with turning packs off when cleared into position for take-off, and ending when packs were turned back on after take-off thrust was reduced to climb thrust or when accomplishing the "after take-off" check list.

### Acronyms and Abbreviations

<b>JAR</b>	Joint Aviation Regulation
<b>ACJ</b>	Advisory Circular Joint
<b>AFM</b>	Airplane Flight Manual

Disclaimer – This document is not exhaustive and it will be updated gradually.



## S-1066: CAT III OPERATIONS - EXCESS DEVIATION ALERT

Equivalent Safety Finding	S-1066: Cat III Operations - Excess deviation alert
APPLICABILITY:	A330-800/-900 / A340-500/-600
REQUIREMENTS:	JAR AWO 236, AWO 321(a)(5)
ISSUE:	4 dated 27/03/2002

### Equivalent Safety Finding summary

#### BACKGROUND

JAR AWO 236(c) requires that excess deviation alerts “must be active at least from 90 m (300 ft) to the decision height but the glide path alert should not be active below 30 ft.”

On A330-800/-900 and A340-500/-600, the localizer (LOC) excess deviation alerts are inhibited under 15ft whatever the kind of autoland operations. Airbus interpretation of JAR AWO 236(c) is that LOC excessive deviation alert is required down to DH, but is not required down to the ground in NO DH operations (The NO DH autoland operation concept is different from operations that would be conducted with a DH =0).

As a consequence, Airbus consider that the design where the LOC excessive deviation alert is inhibited below 15 feet, complies with JAR AWO Change 2 requirement for autoland operation with no DH whereas direct compliance would require that the localizer excess deviation alert be active until the ground.

#### EQUIVALENT SAFETY FINDING

Airbus design for localizer excess deviation alert, whilst not strictly complying with JAR AWO 236 and JAR AWO 321 (a)(5), does meet the intent of the rule and presents an equivalent safety level. This equivalent safety level is based on:

- Airbus technical analysis of relevant failure cases,
- The localizer excess deviation threshold set at 20 micro Amperes, being more severe than the standard required by JAR AWO (25 micro Amperes),
- The design robustness including derotation law and prevention to manually change the ILS course under 700 ft, which can therefore not induce a destabilised approach condition.

- 1) Nominal performances of the AP guidance (without failure) are demonstrated through flight test and simulation. This demonstration account for external perturbations, like crosswind and gusts. In particular, the demonstration of lateral gust during flare is part of the autopilot failure condition simulator assessment. One objective was to check that the guidance remains within LOC excess deviation limits.
- 2) The acceptability of the equivalent safety level is based on a justification that continuing the landing will be safe under the realistic scenarios associated with LOC deviations of greater than

Disclaimer – This document is not exhaustive and it will be updated gradually.



---

20 micro amps at or below 15 feet and that a go-around may safely be performed from any point on the approach to touchdown.

### Acronyms and Abbreviations

<b>AP</b>	AutoPilot
<b>AWO</b>	All Weather Operations
<b>DH</b>	Decision Height
<b>ESF</b>	Equivalent Safety Finding
<b>ILS</b>	Instrument Landing System
<b>JAR</b>	Joint Aviation Regulation
<b>LOC</b>	Localizer

Disclaimer – This document is not exhaustive and it will be updated gradually.



## S-1070 ESF: AFM - RVR LIMITS

Equivalent Safety Finding	S-1070 ESF: AFM - RVR Limits
APPLICABILITY:	A340-500/-600
REQUIREMENTS:	JAR AWO 304, 305, 321, 381, 481
ISSUE:	2 dated 21/11/2001

### Equivalent Safety Finding summary

#### BACKGROUND

The setting of RVR limits is addressed in the applicable operating regulations. To avoid conflict with these regulations and not to compromise operational decision making, the operational specialists of the Authorities have requested that JAR AWO be clarified to avoid RVR minima being expressed as Flight Manual limitations. Instead, information on RVR values, encountered during airworthiness certification, is invited to aid the establishment of operating minima.

The proposed special condition clarifies usage of the RVR term and this special condition is included in the A340-500/-600 Type Certification Basis as an equivalent safety finding.

#### SPECIAL CONDITION

1.1 Revise the introduction to JAR AWO Subpart 3, Section B, 3<sup>rd</sup> paragraph to read:

*"The RVR limit is set by the responsible national authority in accordance with applicable operating regulations and provides visibility at and below the Decision Height..... safety level."*

1.2 Revise the Introduction to JAR AWO Subpart 3, Section C, 2<sup>nd</sup> paragraph, 5<sup>th</sup> sentence, to read:

*" The RVR limit is set by the responsible national authority in accordance with applicable operating regulations."*

1.3 Revise the introduction to JAR AWO Subpart 3, Section D, 1<sup>st</sup> paragraph, by deleting the 2<sup>nd</sup> and 3<sup>rd</sup> sentences and substituting:

*"Any required RVR limit is set by the responsible national authority in accordance with applicable operating regulations."*

1.4 In JAR AWO 304(b), delete the cross reference to JAR AWO 305.

1.5 Delete JAR AWO 305 in its entirety.

1.6 Revise JAR AWO 321(c)(4) to read:

*"Automatic ground roll control or head-up ground roll guidance (see JAR AWO 304)."*

Disclaimer – This document is not exhaustive and it will be updated gradually.



1.7 Delete the references to JARAWO 305 from JARAWO 321(d)(4).

1.8 Delete "(see JARAWO 305 on visibility conditions)" from JARAWO 381(a).

1.9 Revise JARAWO 381(a) by adding the following NOTE:

*"NOTE: Actual RVR minima to be used are subject to operational regulation and may vary from one state to another taking account of local circumstances. For this reason, RVR minima should not be included in the Aeroplane Flight Manual as Limitations. To aid operational assessment and the establishment of landing minima, the RVR values encountered during airworthiness certification may be given."*

1.10 Revise the introduction to JARAWO Subpart 4, 2<sup>nd</sup> paragraph by:

- Deleting the 1<sup>st</sup> and 2<sup>nd</sup> sentences, and substituting:  
*"The RVR limits for take-off of transport aircraft are set by the responsible national authority in accordance with applicable operating regulations.*
- Revising the 3<sup>rd</sup> sentence to read:  
*"The purpose..... to permit a reduction of these limits but not..... visual reference."*
- Deleting the last sentence.

1.11 Revise JARAWO 481(a) by adding the following NOTE:

*"NOTE: Actual RVR minima to be used are subject to operational regulation and may vary from one state to another taking account of local circumstances. For this reason, RVR minima should not be included in the Aeroplane Flight Manual as Limitations. To aid operational assessment and the establishment of take-off minima, the RVR values encountered during airworthiness certification may be given."*

### Acronyms and Abbreviations

<b>AFM</b>	Airplane Flight Manual
<b>AWO</b>	All Weather Operations
<b>RVR</b>	Runway Visual Range
<b>JAR</b>	Joint Aviation Regulation

Disclaimer – This document is not exhaustive and it will be updated gradually.



– END –

Disclaimer – This document is not exhaustive and it will be updated gradually.



TE.CERT.00053-001 © European Aviation Safety Agency, 2019. All rights reserved. ISO9001 Certified. Page 275 of 275  
Proprietary document. Copies are not controlled. Confirm revision status through the EASA-Internet/Intranet.